

Operating Manual

UVAHAND LED

Copyright

All rights reserved

© Copyright by Dr. Hönle AG
Lochhamer Schlag 1
82166 Gräfelfing / München

Printed in Germany, October 2014

No part of this operating manual may be reproduced in any form without the prior written permission of the Dr. Hönle AG.

If any part of this user's manual is reproduced, stored in a retrieval system or transmitted in any form or by any means without obtaining the prior written permission of the Dr. Hönle AG, this will be considered as an infringement of the copyright and legal action will be taken. We reserve the right to effect technical changes for the improvement of the equipment described herein or to raise the safety standard of the said equipment without prior notice.

Responsible for the content: Dr. Hönle AG

Layout: Dr. Hönle AG

Table of Contents

1. Warning notes and symbols in the operating instructions	4
2. Description.....	5
Fields of application	5
Device view	5
3. Safety information.....	6
General information.....	6
Intended use	6
Warranty and Liability.....	7
Risk Group	8
Obligations of the staff	8
Risks in Handling the Device	8
Organizational measures	9
Informal safety measures.....	9
Risks from electrical power	10
Thermal risks.....	10
Risks from UV radiation	11
Risks caused by gases	12
Maintenance and Fault Removal	13
4. Transport, storage, delivery.....	14
5. Installation, setting-up, commissioning and operation	15
General information.....	15
Commissioning.....	15
Switching the UVAHAND LED ON/OFF	15
6. Servicing, maintenance and cleaning.....	16
Maintenance.....	16
Replacing the protective glass unit	16
Surface-cleaning of the UVAHAND LED	17
7. Order data for equipment, spare parts and accessories	18
Devices.....	18
Spare parts.....	18
Accessories	18
8. Faults.....	19
9. Technical data	20
Dimensions and weights	20
Electrical data.....	20
Ambient conditions.....	20

1. Warning notes and symbols in the operating instructions

These operating instructions describe the UVAHAND LED, its operation and its uses. The safety and warning notices explain the safe, proper handling of the device.

You will find the symbols listed below next to all safety and warning instructions in these operating instructions where there is danger to life and limb. An additional signal word indicates the severity of a possible danger.

Observe these notes closely and be especially careful in these cases in order to preclude accidents.

- DANGER!** marks an immediately threatening danger. If it is not avoided, death or very severe injuries will result. Damage to property is possible.
- WARNING!** marks a possible danger. If it is not avoided, death or very severe injuries could result. Damage to property is possible.
- CAUTION!** marks a possible danger. If it is not avoided, slight injury could result. Damage to property is possible.

The symbols used in these operating instructions have the following meaning:



This symbol warns of a hazard area.



This symbol warns of a hot surface.



This symbol warns of hazardous electrical voltage.



This symbol warns of UV radiation.

The two following symbols are used to address practices for optimal operation and/or prevention of damage to the equipment. These information are not related to hazardous situations. Additionally, the signal words **ATTENTION!** and **NOTE!** are used.



ATTENTION!

This symbol with signal word is found at those places in the operating instructions which must be observed so that damage or destruction of the equipment is prevented.



NOTE!

This symbol is found next to notes, tips on operation and useful information.

2. Description

The UVAHAND LED is a high-intensity, mobile hand-held UV-lamp. Its intensive radiation ensures reliable production results within seconds. A homogeneous intensity distribution is guaranteed by the arrangement of the LEDs.

The device is available with emitted wavelengths of 365 or 405 nm +- 10 nm. This allows an adaptation of the hand lamp to the respective application.

Fields of application

Fields of application

The UVAHAND LED can be used for various applications such as:

- the curing of UV reactive adhesives when joining glass, plastics and metals
- the curing of UV reactive compounds on electrical and electronic components
- the production and repair of plastic parts with UV curing polyester resins
- particle control in clean rooms
- authenticity testing
- fluorescent testing for quality control purposes in mechanical engineering, aircraft, textile and printing industry

Device view

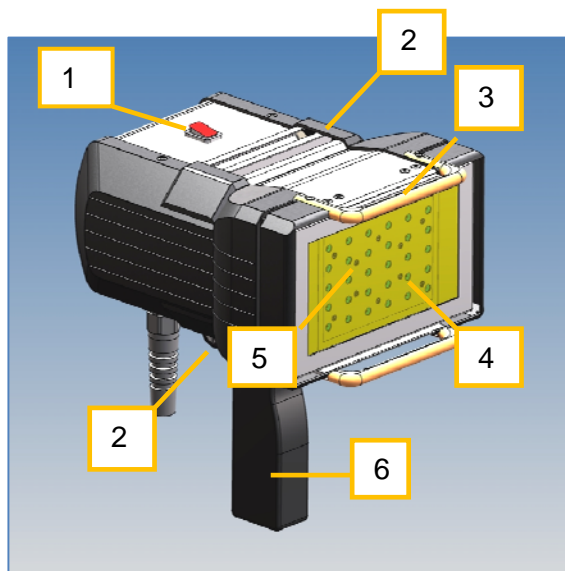

- (1) ON-/OFF-switch
- (2) ventilation openings (housing upper- and underside)
- (3) Spacer bar
- (4) LED-light emitting surface (incl. protective glass unit)¹
- (5) Reflector surface (behind the protective glass)
- (6) Handle
The handle can be rotated 90°; for tripod use or installation purposes the handle can also be removed.

Fig. 1: UVAHAND LED – device view

¹ Protective glass unit = protective glass and protective glass frame

3. Safety information

General information

- A sound knowledge of all basic safety regulations is essential to ensure safe and fault-free operation of the UVAHAND LED.
- This operating manual contains all important safety regulations to ensure safe operation of the device.
- This operating manual, and in particular the safety instructions, must be observed by all persons working with the device.
- In addition, all relevant rules and accident prevention regulations relating to the operation site must be observed.
- At regular intervals, the operator will check that all personnel are observing the safety regulations.
- Under the **Health and Safety Management at Work Regulations 1999**, users are required to carry out a suitable and sufficient assessment of the risks created by the use of the UVAHAND LED.
- They must ensure adequate control measures are in place to minimize or eliminate any of the risks created. The information contained within this manual will assist in creating your own risk assessment.

Intended use

- The UVAHAND LED is a high-intensity, mobile UV-LED-lamp for the irradiation of surfaces. (see also section Fields of application, p. 5).
- Any other or additional usage is regarded as improper use, and is thus dangerous.
- The UVAHAND LED must not be used for medical or therapeutic purposes, for skin-tanning, or in other medical equipment.
- The operator must operate the unit only in accordance with the usage notes in these operating instructions.
- The operator is under obligation to ensure that the prescribed inspections and servicing work are carried out and that the indicated replacement of worn parts is effected.

There are international guidelines for restriction of occupational UV exposures.

Useful references:

- ICNIRP Guidelines on limiting exposure (www.icnirp.de)
- NRPB Advice on protection (www.nrpb.org)

The following are further conditions for intended use:

- the observance of all points listed in the operating manual
- the execution of all servicing and maintenance work
- compliance with the general and specific safety instructions in this manual
- compliance with the relevant accident prevention regulations.

**NOTE**

The Dr. Höhle AG is not liable for damage resulting from improper use of the device.

Warranty and Liability

The Dr. Höhle AG "General Conditions of Sale and Delivery" always apply. They are available to the user on signing the contract, at the latest.

Claims under warranty, and liability for injury to persons and damage to property, are excluded if they can be attributed to one or any of the following:

- Improper use of the UVAHAND LED
- Incorrect assembly, commissioning or operation of UVAHAND LED
- operation of the UVAHAND LED with faulty and/or non-functioning safety and protection devices,
- non-observance of the instructions given in the user's manual with reference to the safety, transport, storage, assembly, commissioning, operation and servicing of the device.
- unauthorized alterations to the construction of the UVAHAND LED
- negligent monitoring of device parts that are subject to wear
- repairs which are carried out incorrectly
- catastrophes, the action of foreign bodies or acts of God.

*Warranty and
Liability*

Risk Group



DANGER!

Improper use can endanger the health of the user or of third parties (severe skin or eye damage)!

The UVAHAND LED comes under the standard DIN EN 62471:2008 („Photobiological safety of lamps and lamp systems “).

It is classified as belonging to Risk Group 2, which requires special safety measures to be observed in its operation.

For further information please refer to the standard DIN EN 62471:2008.

The respective classification and identification of the risk group is shown on the LED head.

Under favorable mounting situations e.g. if appropriate housings have been installed, the risk group can be reduced considerably.

As for all devices that fall within the scope of DIN EN 62471:2008, the operator needs to specify the corresponding risk group, depending on the individual mounting situation

Obligations of the staff

Obligations of the staff

Persons who are assigned to work with the UVAHAND LED are obliged, before starting work:

- to observe the regulations on work safety and accident prevention,
- to read the safety chapter and the warning notices in these operating instructions, and to observe them at all times during operation and
- in particular, to observe the safety measures in DIN EN 62471: 2008 („Photobiological safety of lamps and lamp systems“, IEC 62471:2006, modified).

Risks in handling the device

Risks in Handling the Device

The UVAHAND LED has been built to the latest state of technology and to the recognized safety regulations. Certain risks nevertheless may arise from handling the device, such as:

- Risks from electrical power
- Risks from UV radiation
- Thermal risks

The UVAHAND LED may only be used under the following conditions:

- Personal Protective Equipment (PPE) is worn to protect eyes and skin.
- It is used for the purpose for which it was constructed and
- in a condition in which the device complies with all safety technology requirements.



DANGER!

Improper use of the device can endanger the health of personnel using it or cause a risk to third parties (including the risk of serious skin damage or eye injury). It may also cause damage to the device or other material damage.



UV Radiation

The radiation source of the UVAHAND LED emits UV radiation, see also „Risks from UV radiation“, p. 11.

Safety label on the device



The UV warning label shown on the left is located at the upper side of the device housing.

Safety label on the device

Organizational measures

All safety devices on the device must be regularly tested for correct functioning, prior to carrying out work and at each shift change. Look for external signs of damage.

Organizational measures

Informal safety measures

In addition to this operating manual, the generally and locally applicable accident prevention and environmental protection regulations must be made available and observed.

Informal safety measures

Risks from electrical power

Risks from electrical power

The electrical components of the UVAHAND LED must be inspected regularly.

Before starting work, please inspect the following:

- check all equipment components for external signs of damage

- check that all electric cables are in perfect condition.

Loose connections must be tightened and damaged wiring replaced immediately.



DANGER!

There is a danger of direct or indirect contact with electricity

Thermal risks

Thermal risks

The following safety precautions must be observed when operating the UVAHAND LED:

- Never touch the protective glass when operating the device.
- A safe position (parking place) must be considered for the UVAHAND LED when switched on, but not being hand held. The lamp has spacer bars to create an air gap at the front of the protective glass, but must not be placed on temperature-sensitive or combustible surfaces.
- There must always be a distance of at least 1 m between the device and flammable objects.
- Do not cover the light emitting area of the device.
- **The UV lamp must not be used inside explosion-protected areas.**

Risks from UV radiation

Risks from UV radiation

The UVAHAND LED emits UVA radiation and visible light.



DANGER!

If **improperly handled**, UV radiation can damage skin and eyes! It can lead to severe sunburn or to inflammation of the retina and conjunctiva, and possibly to skin cancer.

The following instructions must be followed when working with the UVAHAND LED:

- Personal safety equipment must be worn to protect the eyes and skin, unless the UV radiation is completely screened by structural measures.
- Goggles should conform the standard EN 170 (max. spectral transmission (365 nm) 0.3 %), and should afford protection from radiation, both directly and from the side.
- Gloves to protect hands should have a Clothing Protection Factor (CPF) of 30+ this is equivalent to the sun protection factor quoted for sunscreens.
- Materials degrade when exposed to UV light, therefore PPE's must be inspected before use. Damaged or items showing signs of ageing must be replaced.
- Never look directly or indirectly into the LED aperture.
- The UVAHAND LED must not be operated without the protective glass.
- The UVAHAND LED must be set up in such a way that persons are not subjected to the radiation, either directly or indirectly. UV-absorbent plastics or metal sheet can be used as shields
- In the case of manual workplaces or in mobile applications, the working area must be enclosed in an appropriate manner.
- The protective glass must be inspected regularly for signs of damage.
- The UVAHAND LED must not be operated unless the protective glass is intact.



NOTE!

Protective articles are listed in the chapter „Order data for equipment, spare parts and accessories“.



CAUTION!

UV radiation can cause damage to electronic components! If EPROMs are used in the vicinity of the UVAHAND LED, they must be protected against UV radiation.



CAUTION!

UV radiation accelerates the aging process of materials!
Surfaces and objects sensitive to UV radiation must be protected before operation.

Risks caused by gases

Risks caused by gases

Some materials under certain conditions can release fumes when irradiated with the UVAHAND LED.

- Observe the safety data sheets for the materials to be radiated.
- Assess the risks created by work involving such substances and establish measures to meet control regulations.
- Refer to the **Control of Substances Hazardous to Health Regulations 1999 (COSHH)**
- Commonly used UV curing adhesives do not release fumes with exposure to UVAHAND 250 GS.
- UV rays encourage the production of ozone. For this reason, it is essential to ensure that the workroom is well ventilated.
- Before beginning of operation, the air pollution at the workplace should be measured. If the air pollution values are increased, an aeration/ventilation system needs to be installed.
- If necessary, you should work using respiratory protection.

Maintenance and Fault Removal

*Maintenance
and fault re-
moval*

The chapter "Servicing, maintenance and cleaning" describes all the necessary maintenance jobs. Carrying these out ensures reliable operation.

The chapter Faults on page 19 contain information on faults which may occur on the UVAHAND LED, possible causes and tips on how to remedy the fault.

Should a fault occur in the device that cannot be rectified with the help of the operating instructions, Dr. Hönle AG Customer Service must be contacted.

Parts that are not in perfect condition must be exchanged immediately. Only Dr. Hönle AG original replacement and wear parts must be used. There is no guarantee that other manufacturers' parts are designed and man-

ufactured to meet the demands of robustness and safety.

No alterations, additions or modifications must be made to the UVAHAND LED without the permission of Dr. Hönle AG.

The contact address for claims under warranty, repair and replacement-part service is as follows:

Dr. Hönle AG
UV-Technology
Lochhamer Schlag 1
D-82166 Gräfelfing / Munich
Tel.: +49 (0)89 / 856 08-0
Fax: +49 (0)89 / 856 08-148
E-mail: uv@hoenle.com
Website: www.hoenle.de



WARNING!

No repairs or alterations must be made to the device except those described in these operating instructions.

4. Transport, storage, delivery

Scope of delivery:

- UVAHAND LED
- Operating manual

Inspect the delivered parts for completeness and damage or other issues.

Any damage found must be documented at once, and reported immediately to the dealer or to Dr. Hönle AG.



NOTE!

Packing material must be disposed of in an environment-friendly way or re-used if possible.

We would recommend that the packing material be kept to protect the equipment if it needs to be shipped onward or otherwise transported.

5. Installation, setting-up, commissioning and operation

General information

General information

- When setting up the UVAHAND LED, ensure that there are no fingerprints on the reflector or the protective glass.
- Never touch the reflector.
- If it is necessary to clean the reflector, the lamp and the filter, do so when they are cold, and always use a clean cloth and isopropyl alcohol.
- Check the air inlets and outlets in the casing before switching the device on.
- There must be no foreign bodies covering or blocking the apertures.
- The UVAHAND LED may only be used in dry rooms.
- Protect the device from chemical fuses.
- When the UVAHAND LED is switched on, never deposit it with the protective glass facing downwards on temperature-sensitive or combustible surfaces.
- The LED-light emitting surface must not be directly covered.
- This will prevent the build-up of heat, which can lead to the destruction of the protective glass. While the spacer bar is fitted, this gap is automatically given, so please do not remove this bar.



DANGER!

Ensure that the cooling is sufficient when setting up the UVAHAND LED. There is acute danger of fire if the device is not sufficiently cooled!
Neither the ambient temperature nor the cooling air temperature may exceed 40 °C.

Commissioning

Commissioning

Connect the mains plug into the socket and switch the device on via the ON/OFF-switch.



DANGER!

The UVAHAND LED may only be connected up to properly installed and earthed sockets.

Switching the UVAHAND LED ON/OFF

*Switching the -
UVAHAND
LED ON/OFF*

The UVAHAND LED is directly switched ON / OFF via the corresponding switch on the upper side of the housing.

6. Servicing, maintenance and cleaning

Maintenance

Maintenance

The following maintenance tasks must be carried out on the UVAHAND LED:

At regular intervals (depending on the operating conditions):

- Check the protective glass unit for dust and other pollutants.
- If required, thoroughly clean the protective glass or replace the protective glass unit.



DANGER!

Before opening the equipment, switch it off and disconnect from the mains. There is a risk of serious, even fatal injury! Let the lamp cool for at least 10 minutes before opening. Acute danger of burns!

Replacing the protective glass unit

Replacing the protective glass unit



DANGER!

Never operate the device with a damaged protective glass or without the protective glass. Doing so may result in health damage due to UV radiation!

The protective glass unit consists of the protective glass and the protective glass frame.

If the protective glass is damaged, the protective glass unit needs to be replaced immediately.



WARNING!

Use only spare parts manufactured by the Dr. Hönle AG. Safe operation of the UVAHAND LED cannot be guaranteed if spare parts from other manufacturers are used.



NOTE!

To order spare parts, see: "Order data for equipment, spare parts and accessories; Spare parts.



DANGER!

Before opening the equipment, switch it off and disconnect from the mains. There is a risk of serious, even fatal injury! Let the lamp cool for at least 10 minutes before opening. Acute danger of burns!

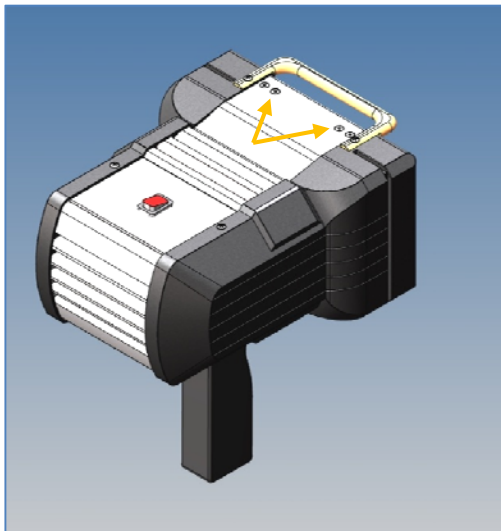

Fig. 2: Securing screws of the protective glass unit (upper / lower housing side)

- Disconnect the device from mains.
- Loosen the two **inner** securing screws on the upper and on the lower side of the housing (Fig. 2).

CAUTION: Do not loosen the two outer screws!



Fig. 3: Removing the protective glass unit

- Now carefully remove the protective glass unit, lifting it by the frame (Fig. 3).
- Take the new protective glass unit and check it for possible contamination.
- If necessary, clean the new protective glass unit and the reflector with a clean, lint-free cloth and alcohol.
- Place the protective glass unit onto the housing.
- Check that the unit fits correctly and then tighten the securing screws.
- If necessary, clean the protective glass again.

The UVAHAND LED is now ready for use.

Surface-cleaning of the UVAHAND LED

Never use aggressive or abrasive cleaning agents to clean the equipment surfaces. Use only mild cleaning agents containing tensides, cleaning cloths or a damp sponge. No moisture must be allowed to penetrate into the device.

Surface-cleaning of the UVAHAND LED

7. Order data for equipment, spare parts and accessories

Accessories or spare parts can be ordered from our spare parts service under the following address:

Dr. Hönle AG
 UV-Technologie
 Lochhamer Schlag 1
 D-82166 Gräfelfing / München

Tel.: +49 (0)89 / 856 08-0
 Fax: +49 (0)89 / 856 08-148

Devices

Devices

Description	Article / Order Number
UVAHAND LED, 365 nm	73900
UVAHAND LED, 405 nm	73901

Spare parts

Spare parts

Description	Article / Order Number
Protective glass unit	73581



WARNING!

Use only original spare parts from the Dr. Hönle AG.
 The operational safety of the UVAHAND LED cannot be guaranteed if other parts are used.

Accessories

Accessories

Description	Article / Order Number
Transport case Systainer	30850
Protective goggles, tinted (for 405 nm)	0067
Protective goggles, clear (for 365 nm)	0068
Protective gloves	19754
Adapter plate for camera stand	73582

8. Faults

The following fault lists contain information on faults which may occur on the UVAHAND LED, possible causes and tips on how to remedy the fault.

If a fault occurs on your device and cannot be remedied by following these instructions, contact the customer service department of the Dr. Hönle AG.

Contact address:

Dr. Hönle AG
 UV-Technologie
 Lochhamer Schlag 1
 D-82166 Gräfelfing / München

Tel.: +49 (0)89 / 856 08-0
 Fax: +49 (0)89 / 856 08-148

Fault	Cause of fault	Remedial action
LEDs do not light up.	Device is not switched on.	<ul style="list-style-type: none"> • Switch the device on.
	Mains plug is not plugged in.	<ul style="list-style-type: none"> • Plug the mains plug in.
	No voltage supply present.	<ul style="list-style-type: none"> • Check the main fuse.

Device becomes too hot and switches off.	Ventilator is not running	<ul style="list-style-type: none"> • Switch device off immediately. Send it to the customer service department.
	The air inlets and outlets of the ventilator are covered or blocked by foreign bodies.	<ul style="list-style-type: none"> • Remove foreign body or covering.

9. Technical data

Dimensions and weights

Dimensions and weights

	Width [mm]	Depth [mm]	Height [mm]	Weight [kg]
UVAHAND LED	180 mm	213 mm	112 mm	1.9 kg

Electrical data

Electrical data

Supply voltage	115 - 230 V
Permitted main voltage fluctuations	+ - 10 %
Mains frequency	50 Hz – 60 Hz
Intensity ^{**)}	365 nm: 130 mW/cm ² 405 nm: 300 mW/cm ²
Light emitting area	approx. 137 x 75 mm
Power consumption	64 W
Balancing process according to overvoltage category II	

^{**)} measured with Hönle UV meter, surface sensor LED at a distance of 20 mm

Ambient conditions

Ambient conditions

Place of installation	Only in closed rooms
Temperature range	+5 °C to +40 °C
Air humidity	Maximum relative air humidity 80 % for temperatures up to 31 °C, linear reduction down to 50 % relative humidity at 40 °C
Pollution degree	2, according to IEC 664



Dr. Höhle AG
UV-Technology
Lochhamer Schlag 1
D-82166 Gräfelfing/München
Tel.: +49 (0)89 / 856 08-0
Fax: +49 (0)89 / 856 08-148