

SERIE IMBOTTE

MURATURA / CARTONGESSO

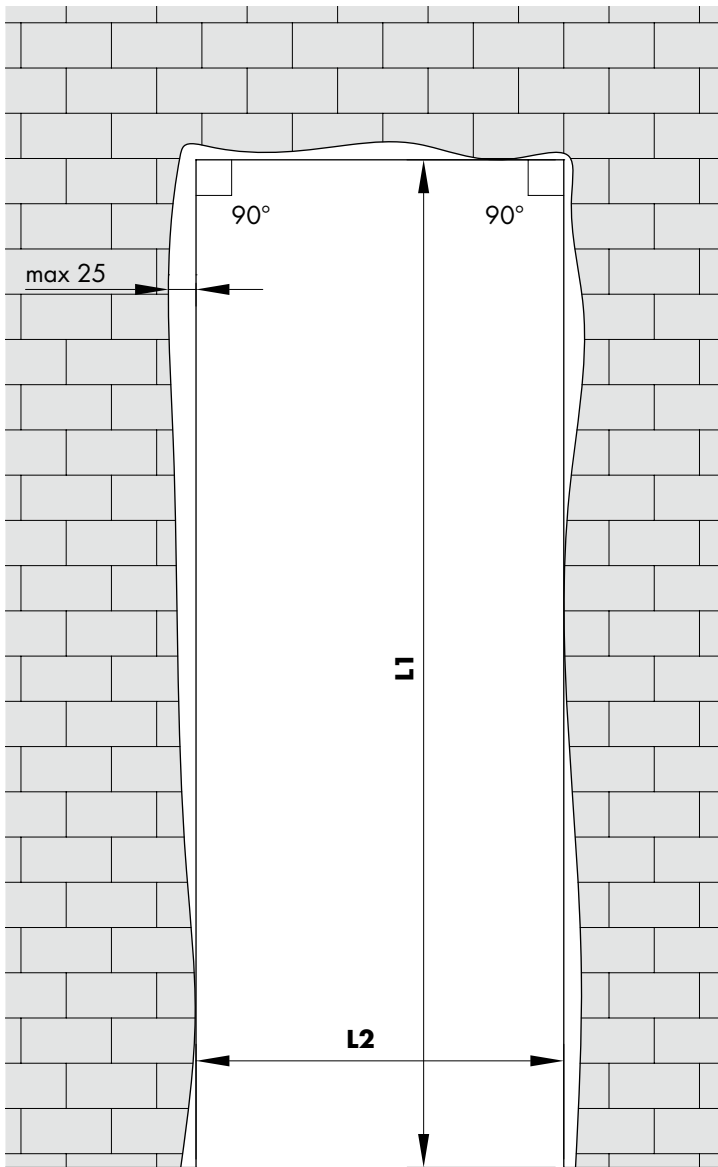



Dimensioni e tolleranze vano porta

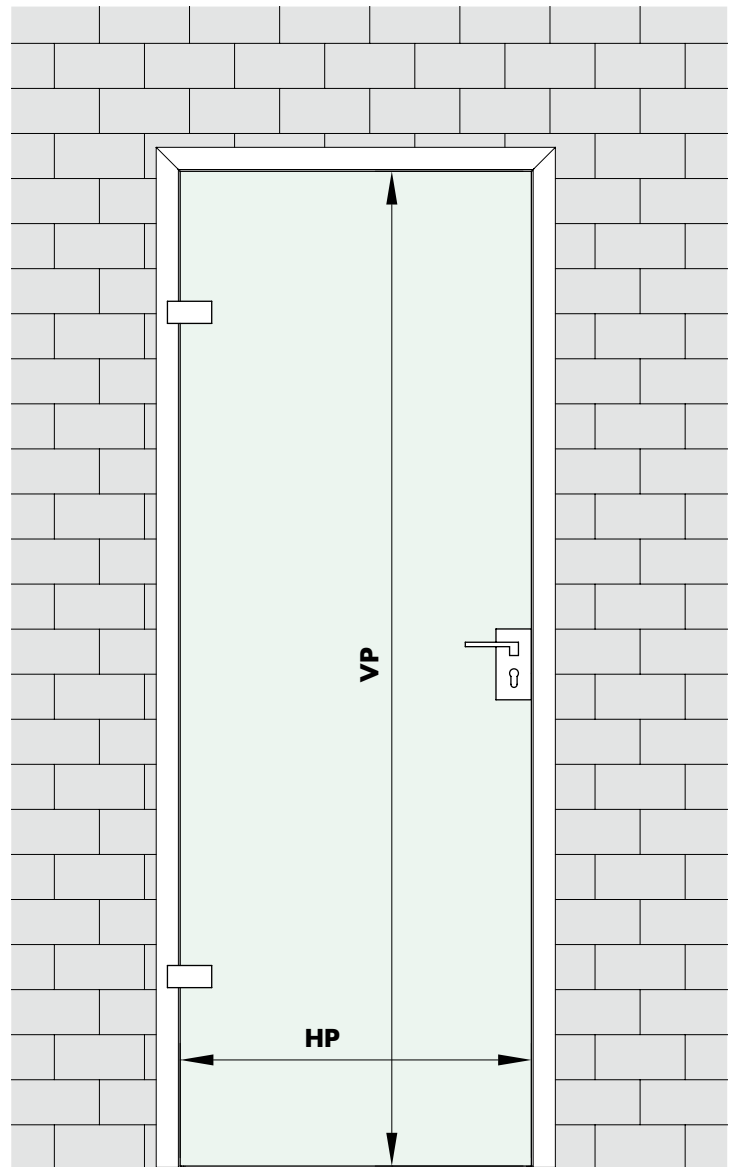

Dimensioni dell'anta in vetro

$$HP = L2 - 2G - 2A - 20\text{mm}$$

$$VP = L1 - G - 2A - 10\text{mm}$$

G = gioco minimo desiderato tra parete e imbotte

A = aria prevista tra imbotte e anta in vetro

* per la compensazione del gioco **G** si consiglia l'utilizzo di spessori:
SPE2402/03/04/05/06/07

Se non diversamente specificato:

G = 3mm e **A** = 4mm

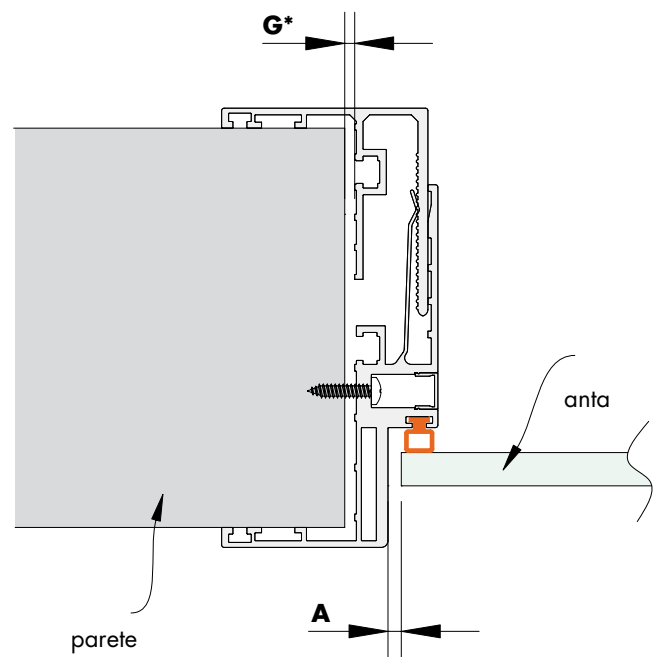

SEQUENZA MONTAGGIO PROFILI

•1

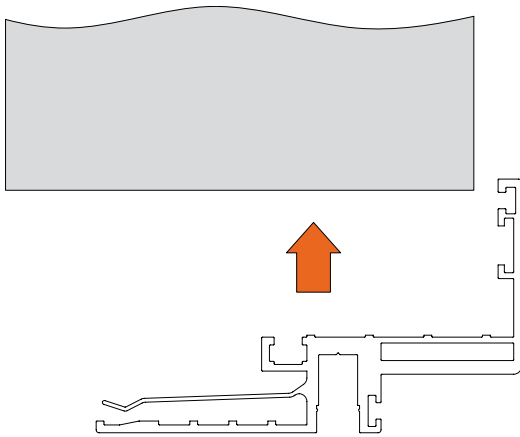

•2

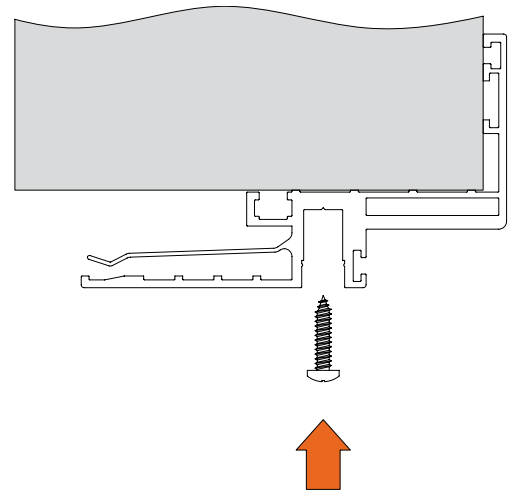

•3

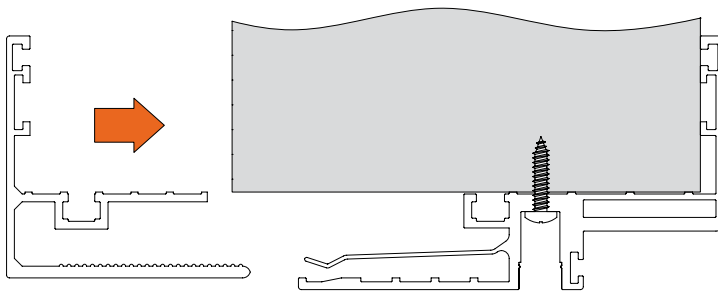

•4

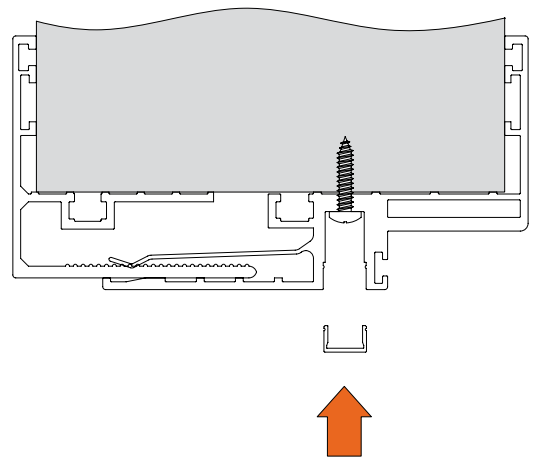

•5

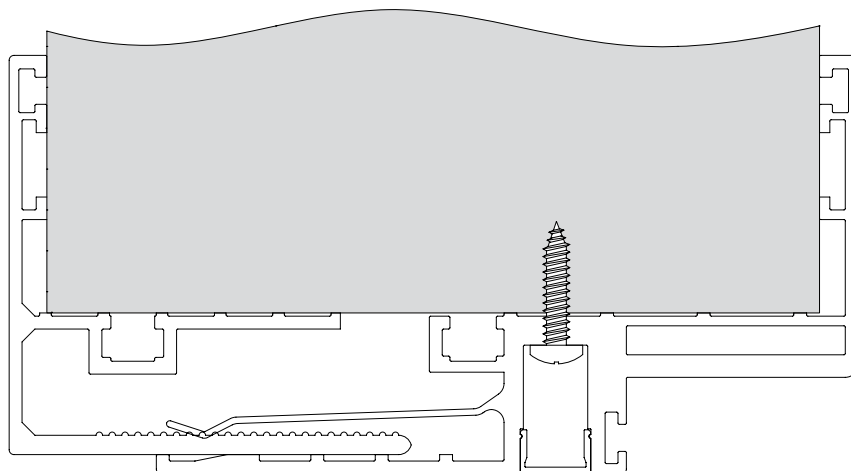

FASE 1: Inserire Guarnizioni dove previsto

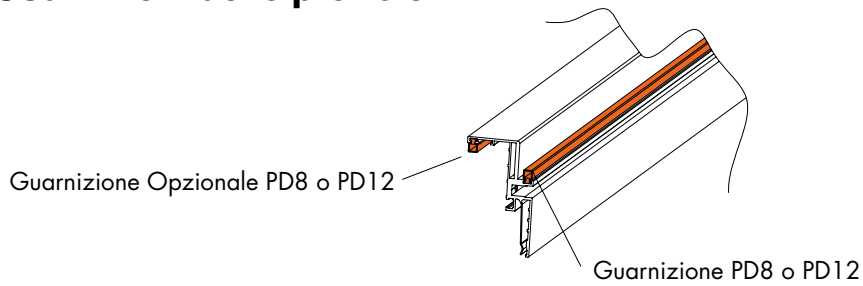

FASE 2: Montaggio profili portanti

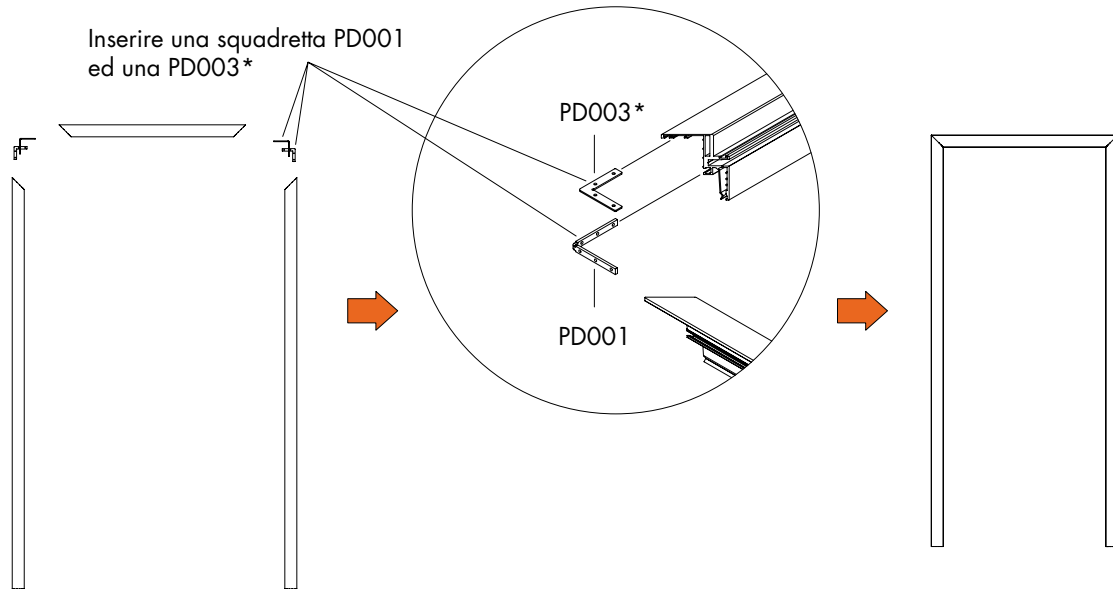

*** Coppia di serraggio = 0,4 Nm**

FASE 3: Montaggio imbotte portante su parete

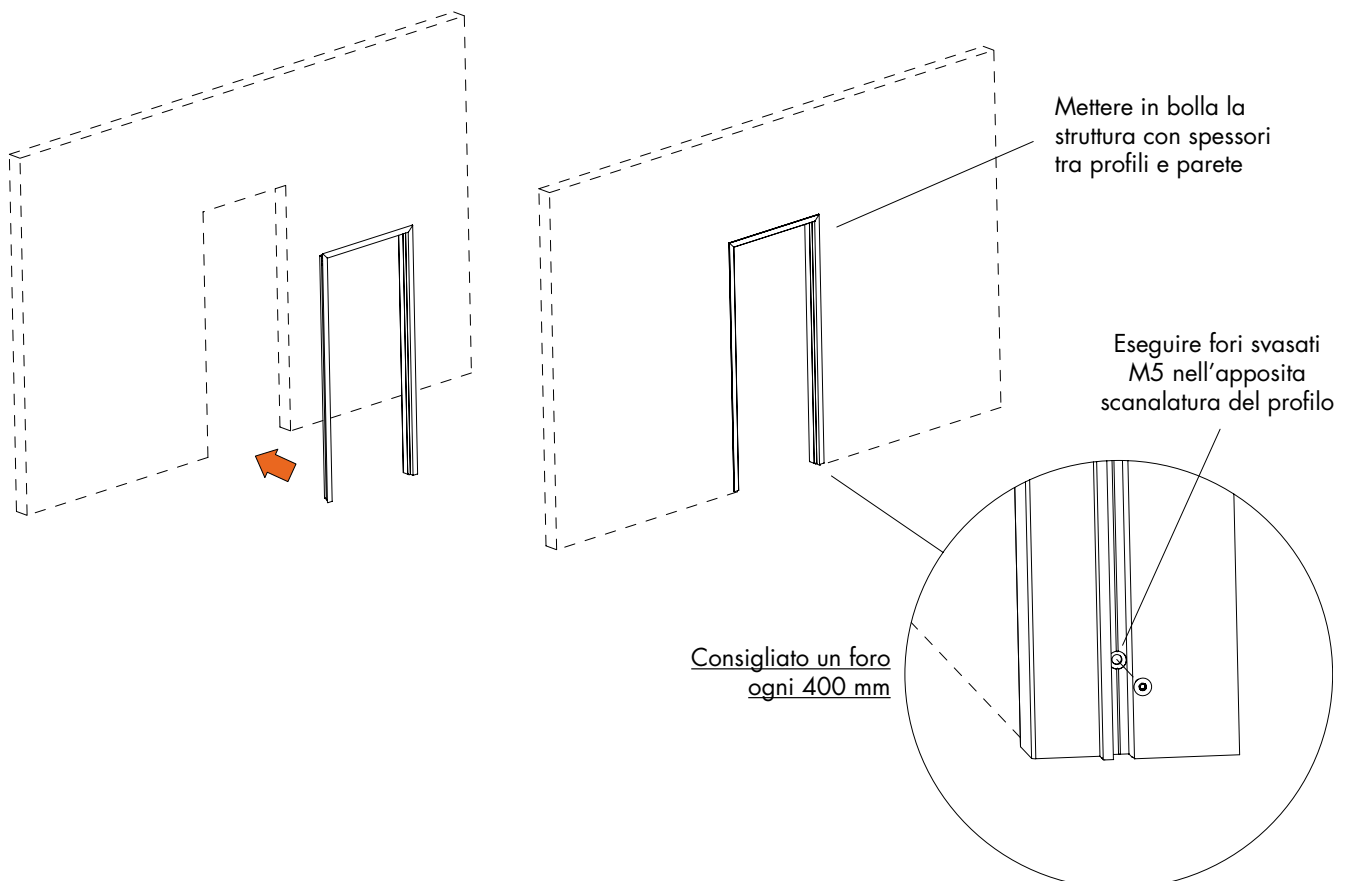

**FASE 4: Montaggio profili
chiusura posteriori**

Inserire una
squadretta PD001
ed una PD003*

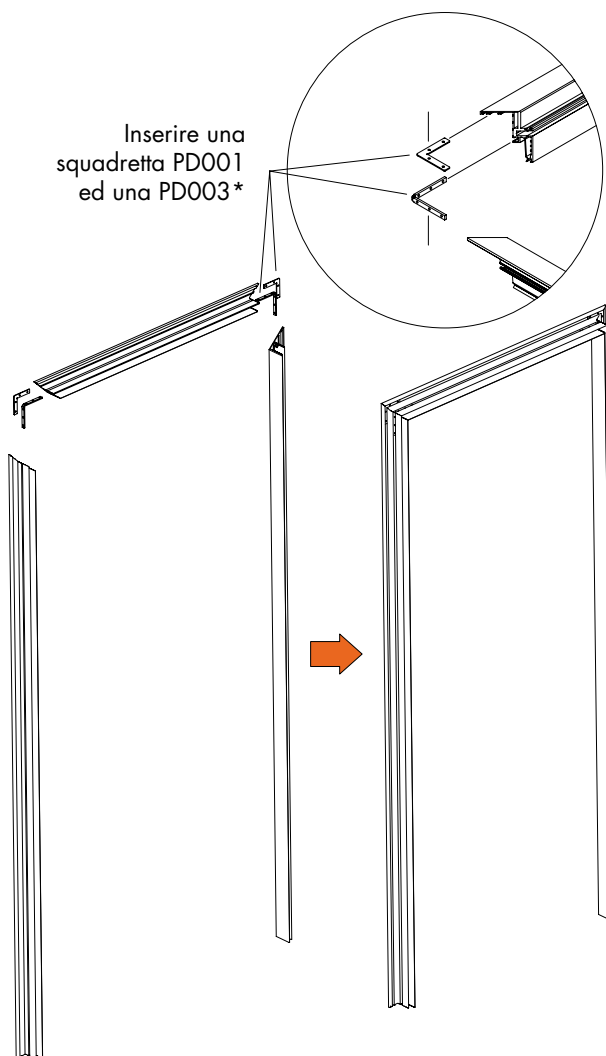

**FASE 5: Inserire l'imbotte
di chiusura posteriore
sull'anteriore**

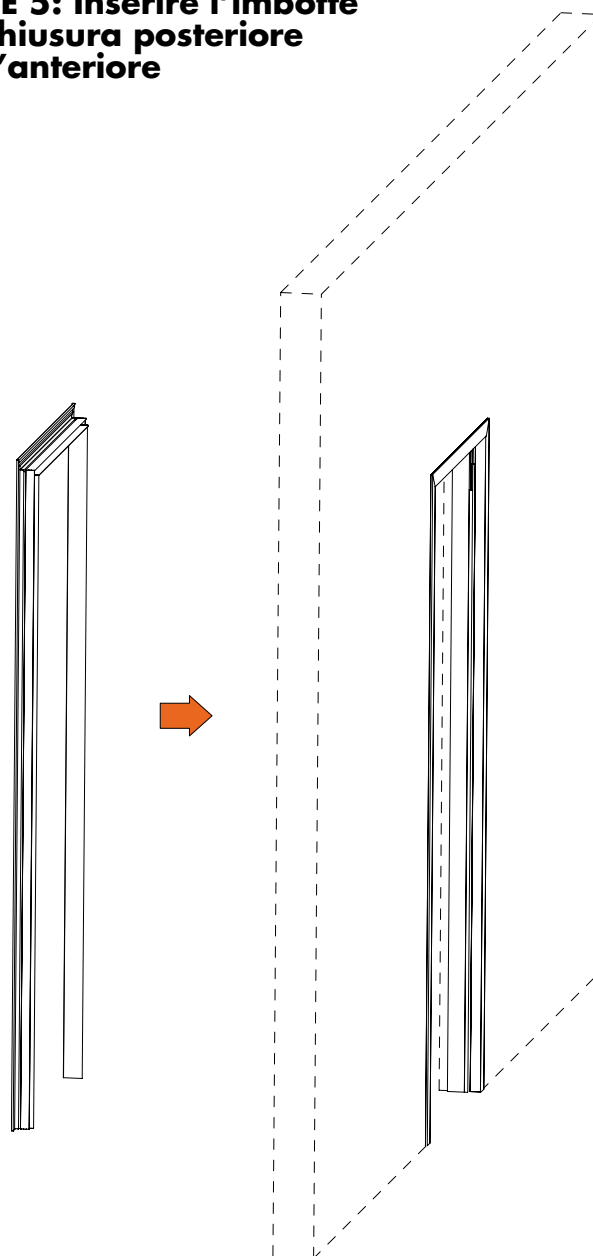

* Coppia di serraggio = 0,4 Nm

FASE 6: Inserire il carter di copertura viti ad incastro

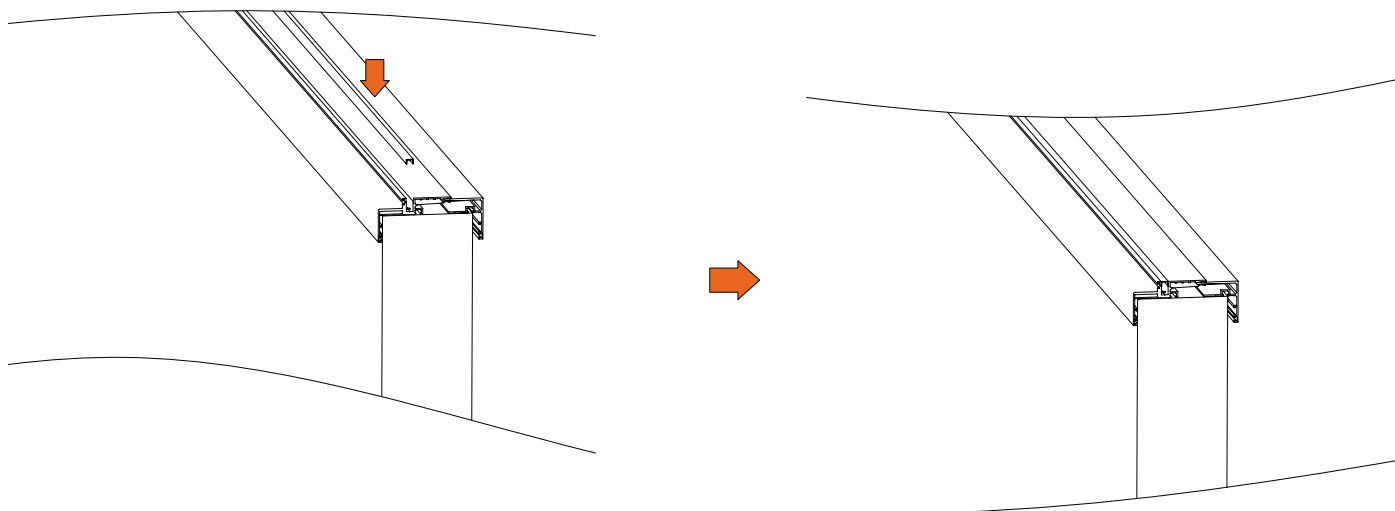

Le immagini ed i dati contenuti nel presente catalogo sono da ritenersi indicativi e possono subire variazioni anche senza alcun preavviso



LOGLI MASSIMO SpA
Via Chemnitz, 49/51
59100 Prato - Italia
Tel. +39.0574.701035
Fax +39.0574.527574
www.loglimassimo.it
info@loglimassimo.it



SPONSOR



Fornitore Ufficiale

ASSOCIATED PARTNERS

