



POLITECNICO
MILANO 1863

LABORATORIO PROVE MATERIALI

Spett.le
LOGLI MASSIMO S.P.A.
VIA CHEMNITZ 49/51
59100 PRATO (PO) - ITA

Test report N. 2022/2175 issued in Milan 11/07/2022

Client: LOGLI MASSIMO S.P.A.- PRATO (PO) – ITALIA

Specimen entry: 23/05/2022

TEST REPORT

Test on glass balustrade model “DEFENDER” DF810LM with 88.4 tempered PVB

In the following pages are reported:

- Specimen description and test procedure;
- Test results.

The results are related only to the tested specimens.

The test report consists of 14 pages.

The test report can be only completely reproduced in full and shall be subjected to stamp duty for use according to Italian law D.P.R. 642/72.

THE SERVICE HEAD

Roberto Minerva

Digitally signed in accordance with current legislation.

Sede di Milano - Ufficio Accettazione materiale e Certificazione
via Celoria, 3 – 20133 Milano – Tel. 02 2399 4210 Fax 02 2399 4211

Sede di Lecco
via Gaetano Previati 1/C – 23900 Lecco – Tel. 0341/48 8793 Fax 0341/48 8771



POLITECNICO
MILANO 1863

LABORATORIO PROVE MATERIALI

INDEX

1. Introduction
2. Reference standards
3. Specimen identification
4. Test procedure
5. Test results
6. Conclusions

1. INTRODUCTION

This test report presents the results of static and dynamic tests on glass balustrades according to the reference standard (Cahier du CSTB 3034_V3).

Tests were performed at LPMSC (Materials, Structures and Constructions Laboratory) of Politecnico di Milano on the 23/05/2022 at the presence of the following persons:

Mr. Daniele Spinelli (Politecnico di Milano)

Prof. Eng. Ph.D. Sara Cattaneo (Politecnico di Milano)

Eng. Ph.D. Lorenzo Piscitelli (Logli Massimo S.p.A. Saint-Gobain)

2. REFERENCE STANDARDS

Cahier du CSTB 3034_V3- Garde-corps non traditionnels en produits verriers encastrés en pied

3. SPECIMEN IDENTIFICATION

Two glass balustrade specimen assemblies were put together, with identical procedure and components: one specimen was used for static tests, the other specimen was used to perform dynamic tests. Specimens consist in a base rail in aluminium with and a laminated glass panel. The aluminium base rail is anchored to a concrete base structure which acts as support for the whole assembly.

Laminated glass specimens consist in two 8 mm tempered glass plies which are joined through 1.52 mm PVB interlayer. Before lamination, individual glass panels were subject to HST according to EN 14179 (Fig. 3.1).

Glass specimens had dimension of 1.0m x 1.075m (height of the balustrade from the finished floor 1.1m) and were installed with the system “DEFENDER DF810LM”, with a length of 1.0m. The system uses aluminium profiles AW 6063 T6, extruded according to EN 573 and EN 755-2, with holes at the bottom and named “DF810LM”. One profile

The Technical Head
Sara Cattaneo

Digitally signed in accordance with current legislation.

Milano headquarter- Material Acceptance and Certification Office
via Celoria, 3 – 20133 Milano – Phone +39 02 2399 4210 Fax +39 02 2399 4211

Lecco headquarter
via Gaetano Previati 1/C – 23900 Lecco – Phone +39 0341/48 8793 Fax +39 0341/48 8771

Official Laboratory (art. 20 Law n. 1086 del 5 November 1971) – NB 1777 Reg. (UE) 305/2011



POLITECNICO
MILANO 1863

LABORATORIO PROVE MATERIALI

was used for static tests and a second identical profile was used for impact tests. The tested profiles both had a length of 1.0m with equally spaced holes (center to center distance 200mm) with the first hole at 100 mm. The profiles are anchored with a total of 3 concrete screws spaced 400 mm apart one another (anchors reference: Fischer model FBS 10 x 100/15 US A4 as in ETA-11/0095).

The system “DEFENDER DF810LM” includes plastic clamps (POM) reference DF1721, with moving aluminium wedges via a stainless steel M6 screw, and aluminium finishing profiles with TPE sealing gaskets, (Fig. 4.1a). The installation of the glass in the aluminium profile was done with 4 clamps spacing 250 ± 10 mm (Fig. 4.1b).

The measure of the tempered glass pre-stress was made by the laboratory before the beginning of the tests on both specimens (the one used for static tests and the one used dynamic tests) with Laser GASP Grazing Angle Surface Polarimeter. Measured surface stress on the glass installed on the inner side of the balustrade was 104.19 MPa (both for static loads tested and dynamic loads tested laminated glass specimen).

The balustrade was installed on a concrete element C20/25 casted according to TR048 – EOTA -2016. The average concrete compressive strength (cubic) equal to 30 MPa.

The code of the static test is S-DF810LM-8T8T-4PVB (type of test (S)- static – profile code (DF810LM)- thickness and type of glass (8T-8T) interlayer type (4PVB)).

Similarly, dynamic tests are identified by the type of test: Hard body (H) or semi-hard body (SH) – profile - thickness and type of glass - interlayer type - number of the impact points (1, 2 or 3) according to the code.



Figure 3.1 Glass label

The Technical Head
Sara Cattaneo

Digitally signed in accordance with current legislation.

Milano headquarter- Material Acceptance and Certification Office
via Celoria, 3 – 20133 Milano – Phone +39 02 2399 4210 Fax +39 02 2399 4211

Lecco headquarter
via Gaetano Previati 1/C – 23900 Lecco – Phone +39 0341/48 8793 Fax +39 0341/48 8771

Official Laboratory (art. 20 Law n. 1086 del 5 November 1971) – NB 1777 Reg. (UE) 305/2011



POLITECNICO
MILANO 1863

LABORATORIO PROVE MATERIALI

4. TEST PROCEDURE

Both static and dynamic tests were performed on specimens installed according to the following procedure:

1. marking of anchor points on the concrete base using the profile as template and checking the correct position with a level (cf. center to center position as above §3),
2. vertical drilling of the concrete slab at an embedment depth of 120 mm at set anchor points,
3. cleaning of the dust in and around all drilled holes,
4. installation of the U shaped aluminium profile with anchors,
5. tightening of the anchors with a torque of 40 Nm,
6. assembly of the clamps on the glass with spacing of 250 mm,
7. insertion of the glass and the clamps into the aluminium profile,
8. clipping of fixing rollers,
9. adjustment of the glass in vertical position by tightening and loosening clamps on both sides at ~0.1 Nm.
10. once the correct position is set, final tightening of the clamps with a torque moment of 2 Nm (torque wrench BETA 583/6 (SN2014/123169) was used to check correct tightening of the clamps,
11. inserting of the gaskets in the finishing profiles and snap pose of the finishing profiles on the U shaped aluminium profile.

The installation was done according to instructions and with the supervision of the company Logli Massimo. Tests were performed once the glass was in place in the system.

During all tests the temperature and the relative humidity were monitored with Extech Instrument RH520 Temperature and Humidity Recorder.

The Technical Head
Sara Cattaneo

Digitally signed in accordance with current legislation.

Milano headquarter- Material Acceptance and Certification Office

via Celoria, 3 – 20133 Milano – Phone +39 02 2399 4210 Fax +39 02 2399 4211

Lecco headquarter

via Gaetano Previati 1/C – 23900 Lecco – Phone +39 0341/48 8793 Fax +39 0341/48 8771

Official Laboratory (art. 20 Law n. 1086 del 5 November 1971) – NB 1777 Reg. (UE) 305/2011



POLITECNICO
MILANO 1863

LABORATORIO PROVE MATERIALI

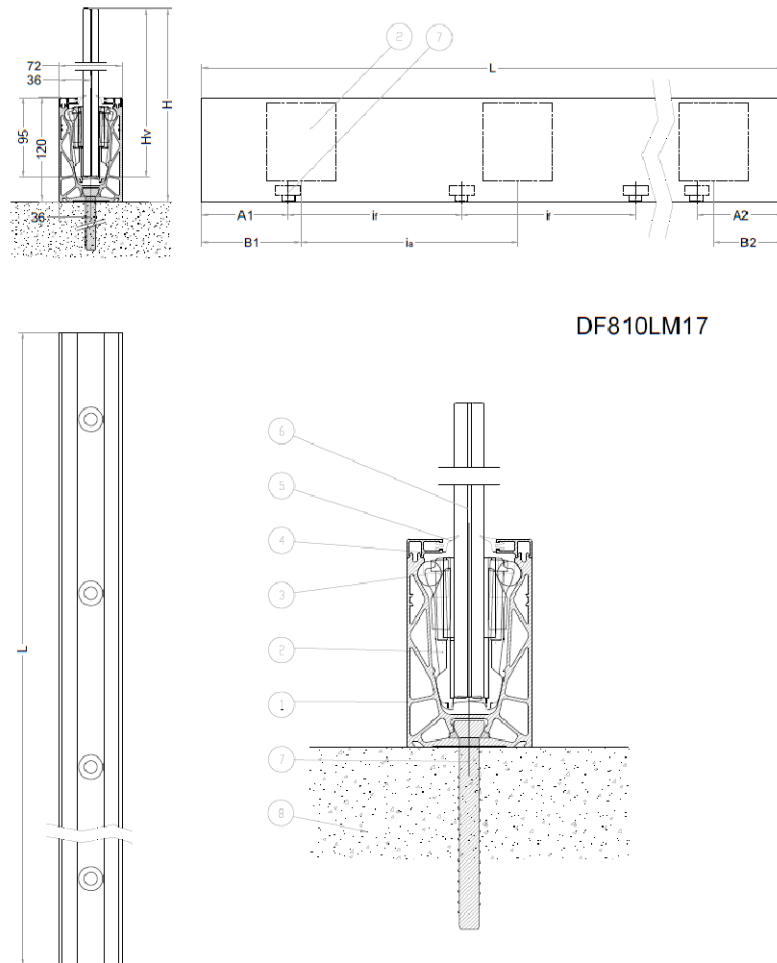

DF810LM17

Installation details			
Ref.	Description	U	Measure
A1	First anchor position	mm	100
A2	Last anchor position	mm	100
i_r	Spacing of the anchors	mm	400
B1	First clamp position	mm	125
B2	Last clamp position	mm	125
i_a	Spacing of the clamps	mm	250
L	Length of the specimen	mm	1000
Hv	Height of the glass ply	mm	1075
H	Total height of the balustrade	mm	1100

LEGEND

- 1) aluminium structural profile (ref. DF810LM.60/97)
- 2) clamp with aluminium wedge and adjusting M6 stainless steel screw (ref. DF1721)
- 3) fixing rollers (part of ref. DF1721)
- 4) Finishing aluminium profile (ref. DF100.60/97)
- 5) TPE gaskets (ref. DFP88G01)
- 6) laminated glass ply
- 7) Anchors
- 8) base structure

Figure 4.1a System DEFENDER DF810LM cantilevered balustrade system

The Technical Head
Sara Cattaneo

Digitally signed in accordance with current legislation.

Milano headquarter- Material Acceptance and Certification Office
via Celoria, 3 – 20133 Milano – Phone +39 02 2399 4210 Fax +39 02 2399 4211

Lecco headquarter
via Gaetano Previati 1/C – 23900 Lecco – Phone +39 0341/48 8793 Fax +39 0341/48 8771

Official Laboratory (art. 20 Law n. 1086 del 5 November 1971) – NB 1777 Reg. (UE) 305/2011



POLITECNICO
MILANO 1863

LABORATORIO PROVE MATERIALI

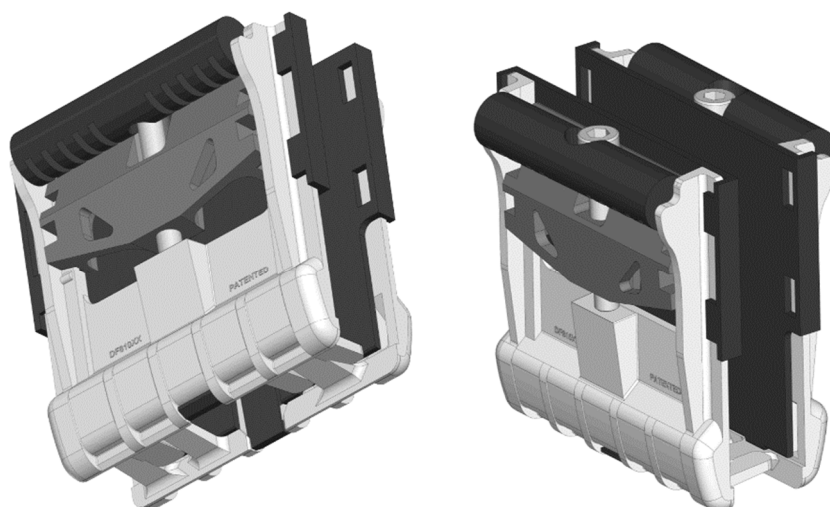

Figure 4.1b Clamps for the system DF810LM ref. DF1721

The Technical Head
Sara Cattaneo

Digitally signed in accordance with current legislation.

Milano headquarter- Material Acceptance and Certification Office
via Celoria, 3 – 20133 Milano – Phone +39 02 2399 4210 Fax +39 02 2399 4211

Lecco headquarter
via Gaetano Previati 1/C – 23900 Lecco – Phone +39 0341/48 8793 Fax +39 0341/48 8771

Official Laboratory (art. 20 Law n. 1086 del 5 November 1971) – NB 1777 Reg. (UE) 305/2011



4.1 Static test

The test was performed with a loading system made of a dead load applied in the middle to simulate the load from outside to inside and of four pneumatic jacks attached to the strong floor and that apply the load via four ties attached to the upper edge of the balustrade with spacing 25 cm to simulate the load from inside to outside. The sketch of the testing system is shown in Fig. 4.2.

The applied load of each jack was monitored via load cell (AEP TC4 S.N. 430971 -400896 – 715249 – 440041, class 1).

The load measured by the 4 cells was acquired by control system PLC Siemens S7 with specific software designed to maintain a uniform load in the four points.

The displacements were measured with three wire transducers WAYCON SX50-750-1R-KA02, placed at 1m from the top concrete surface, at midspan (S.N. 17555215) and with spacing of 25 cm (S.N. 18561245 (left), 17555213 (right)) (Fig.4.2). All data (4 load cells and 3 displacement transducers) were acquired by Spider 8 HBM data acquisition system with specimen frequency of 2 Hz.

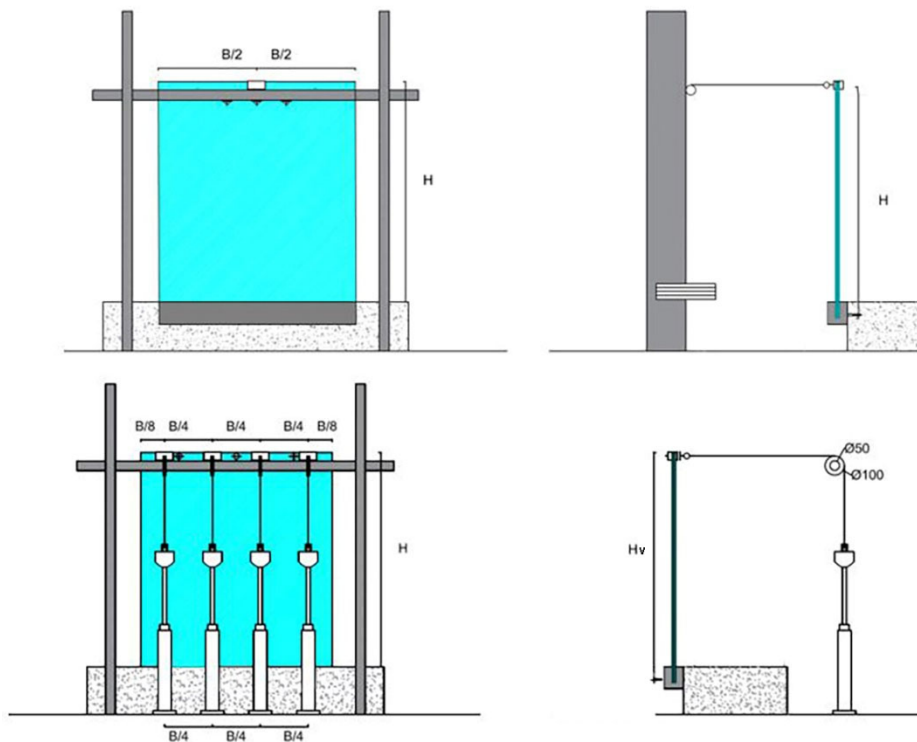

Figure 4.2 – Static test –Sketch of the testing system– Front and lateral view (measure in mm) load from outside to inside (top) from inside to outside (bottom)

The Technical Head
 Sara Cattaneo

Digitally signed in accordance with current legislation.

Milano headquarter- Material Acceptance and Certification Office
 via Celoria, 3 – 20133 Milano – Phone +39 02 2399 4210 Fax +39 02 2399 4211

Lecco headquarter
 via Gaetano Previati 1/C – 23900 Lecco – Phone +39 0341/48 8793 Fax +39 0341/48 8771

Official Laboratory (art. 20 Law n. 1086 del 5 November 1971) – NB 1777 Reg. (UE) 305/2011



POLITECNICO
MILANO 1863

LABORATORIO PROVE MATERIALI

The load was applied in the following steps:

From outside to inside:

1. A load of 20 daN was applied for 180 seconds at the top level in the middle of the balustrade (direction from outside to inside)
2. Unload, waiting for the stabilization of the resting position and reset of the displacement transducers
3. A load of 40 daN was applied for 180 seconds while measuring the displacement continuously
4. Unload, waiting for the stabilization of the resting position and check of the residual displacement, reset of the displacement transducers

From inside to outside the following procedure was carried out to account for both private and public use:

1. A load of 60 daN/m was applied for 180 seconds while measuring the displacement continuously
2. Unload, waiting for the stabilization and reset of the displacement transducers
3. A load of 60 daN/m was applied for 180 seconds while measuring the displacement continuously
4. Unload, waiting for the stabilization of the resting position and check of the residual displacement
5. A load of 180 daN/m (60 daN/m x 3 (safety factor)) was applied for 900 seconds
6. Unload

4.2 Dynamic tests

4.2.1 Hard body impact test

The test was performed using as impactor a tempered steel ball with a diameter of 63.5 mm and weight of 1000 g sustained by an inextensible wire with negligible weight according to the reference code. 3 impact points have been defined according to the sketch shown in Figure 4.4a:

Point 1: along the centerline at a distance of 100 mm from the upper edge of the specimen.

Point 2: along the centerline at half height of the element

Point 3: close to the profile.

The impactor was connected at a fixed point at a distance equal to 180 cm from point 1, 225 cm from point 2 and about 265 cm from point 3. The impactor was placed in contact with the selected point with the wire perpendicular to the floor. For all impact points, the steel ball was lifted 1020 mm with respect to the rest position (impact energy equal to 10 J).

The impactor position was measured with Bosch DLE40 (class II precision ± 1.5 mm).

Each point was hit once.

At the end of the test, the glass was visually inspected to check damages and or anomalies.

The Technical Head
Sara Cattaneo

Digitally signed in accordance with current legislation.

Milano headquarter- Material Acceptance and Certification Office
via Celoria, 3 – 20133 Milano – Phone +39 02 2399 4210 Fax +39 02 2399 4211

Lecco headquarter
via Gaetano Previati 1/C – 23900 Lecco – Phone +39 0341/48 8793 Fax +39 0341/48 8771

Official Laboratory (art. 20 Law n. 1086 del 5 November 1971) – NB 1777 Reg. (UE) 305/2011



POLITECNICO
MILANO 1863

LABORATORIO PROVE MATERIALI

4.2.2 Soft body impact test

The test was performed using as impactor with a mass of 50 kg according to the standard P 06-301 (Fig.4.3). Two impact points have been defined according to the sketch shown in Figure 4.4b (choose according to the reference):

Point 1: along the centerline at 250 mm from the top of the element

Point 2: at a distance of 250 mm from the edge at one third of the height of the element.

The impactor was connected at a fixed point and was placed in contact with the selected point with the wire perpendicular to the floor. Then it is uplifted at the height of 1840 mm with respect to the rest position (Impact 900J -point 1) and at height of 1430 mm (Impact 700J - point 2).

The impactor position was measured with Bosch DLE40 (class II precision ± 1.5 mm). Each point was hit once. At the end of the test, the glass was visually inspected to check damages and/or anomalies.

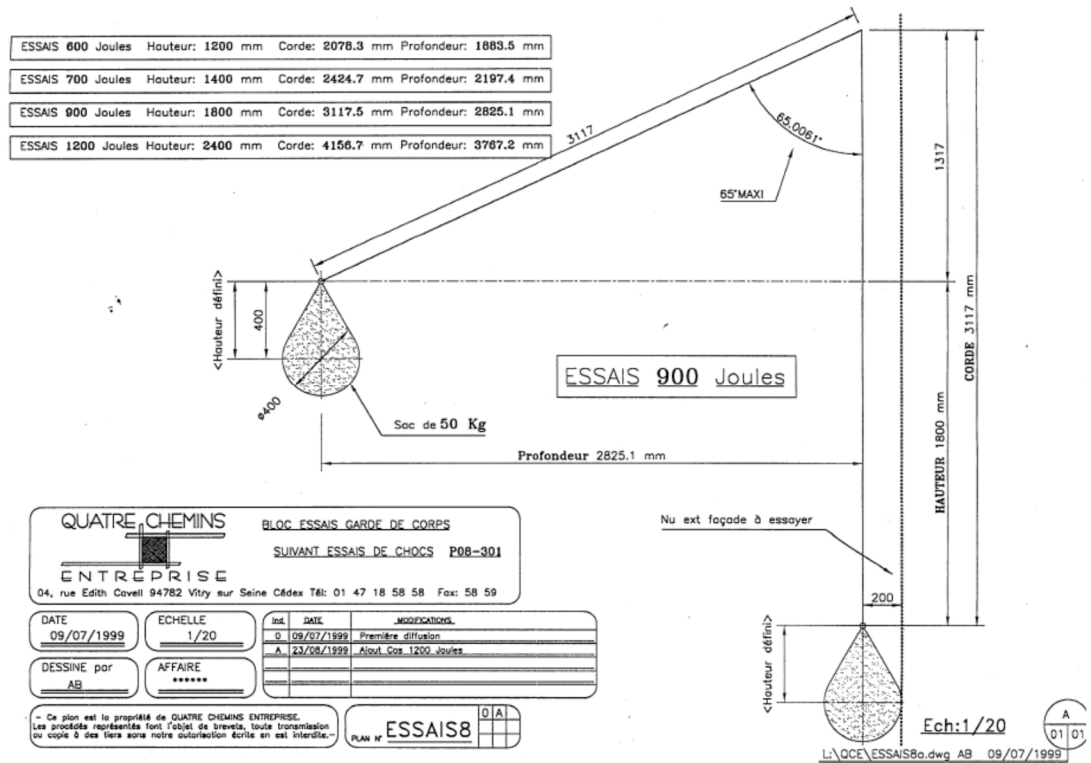

Figure 4.3 – Characteristic of the soft body impactor

The Technical Head
Sara Cattaneo

Digitally signed in accordance with current legislation.

Milano headquarter- Material Acceptance and Certification Office
via Celoria, 3 – 20133 Milano – Phone +39 02 2399 4210 Fax +39 02 2399 4211

Lecco headquarter
via Gaetano Previati 1/C – 23900 Lecco – Phone +39 0341/48 8793 Fax +39 0341/48 8771

Official Laboratory (art. 20 Law n. 1086 del 5 November 1971) – NB 1777 Reg. (UE) 305/2011

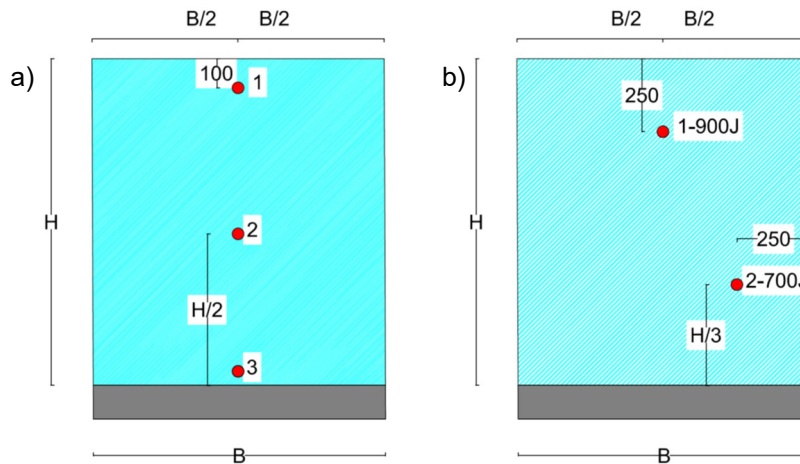

Figure 4.4 – Dinamic tests: Impact points (a) hard body (b) soft body (measure in mm)

5. TEST RESULTS

5.1 Static test

The average temperature and the relative humidity of the laboratory during the tests were equal to 20.6°C and 51% respectively.

5.1.1 Specimen S- DF810LM-10T10T-4PVB

Table 5.1 reports the main displacements and requirements at the different stages. Figure 5.1 shows the specimens subjected to load.

Table 5.1 – Displacements at the main load steps – Specimen S- DF810LM-10T10T-4PVB

STEP	LOAD [daN]	REQUIREMENTS	OBSERVATIONS	
SLS INWARDS LOAD	20	-	Displacement under load = 6.24 mm	-
SLS INWARDS LOAD	40	residual displ. < 2 mm (after 15')	Displacement under load = 10.89mm Residual displacement = 0.87mm	OK

STEP	LOAD [daN/m]	REQUIREMENTS	OBSERVATIONS	
SLS OUTWARDS LOAD	60	max. displ. ≤ 35 mm	Displacement under load = 15.82 mm	OK
SLS OUTWARDS LOAD	60	max. displ. ≤ 35 mm residual displ. ≤ 3 mm (after 15')	Displacement under load = 15.36 mm Residual displacement = 0.80 mm	OK
ULS OUTWARDS LOAD	180	No glass breakage	Displacement under load = 63.63 mm	OK

The Technical Head
Sara Cattaneo

Digitally signed in accordance with current legislation.

Milano headquarter- Material Acceptance and Certification Office
via Celoria, 3 – 20133 Milano – Phone +39 02 2399 4210 Fax +39 02 2399 4211

Lecco headquarter
via Gaetano Previati 1/C – 23900 Lecco – Phone +39 0341/48 8793 Fax +39 0341/48 8771

Official Laboratory (art. 20 Law n. 1086 del 5 November 1971) – NB 1777 Reg. (UE) 305/2011



POLITECNICO
MILANO 1863

LABORATORIO PROVE MATERIALI



Figure 5.1 – Specimen subjected to load

5.2 Dynamic tests

The average temperature and the relative humidity of the laboratory during the tests were equal to 20.3°C and 51% respectively.

5.2.1 Hard body test – Specimen H- DF810LM-10T10T-4PVB

Points 1-2-3 – The hard body did not cause any damage.

5.2.2 Soft body impact test – Specimen SH- DF810LM-10T10T-4PVB

Point 1-2 – The soft -body did not cause any damage as shown in Fig. 5.2.

The Technical Head
Sara Cattaneo

Digitally signed in accordance with current legislation.

Milano headquarter- Material Acceptance and Certification Office
via Celoria, 3 – 20133 Milano – Phone +39 02 2399 4210 Fax +39 02 2399 4211

Lecco headquarter
via Gaetano Previati 1/C – 23900 Lecco – Phone +39 0341/48 8793 Fax +39 0341/48 8771

Official Laboratory (art. 20 Law n. 1086 del 5 November 1971) – NB 1777 Reg. (UE) 305/2011



Figure 5.2 – Specimen SH- DF810LM-10T10T-4PVB – Impact points 1-2

The Technical Head
Sara Cattaneo

Digitally signed in accordance with current legislation.

Milano headquarter- Material Acceptance and Certification Office
via Celoria, 3 – 20133 Milano – Phone +39 02 2399 4210 Fax +39 02 2399 4211

Lecco headquarter
via Gaetano Previati 1/C – 23900 Lecco – Phone +39 0341/48 8793 Fax +39 0341/48 8771

Official Laboratory (art. 20 Law n. 1086 del 5 November 1971) – NB 1777 Reg. (UE) 305/2011



POLITECNICO
MILANO 1863

LABORATORIO PROVE MATERIALI

6. CONCLUSIONS

The tested guardrail complies with static and dynamic requirements according to specifications in Cahier3034v3 du CSTB for non-traditional cantilevered glass balustrades for buildings in Cat. A and B.

Specimen details:

System: **DF810LM**
laminated glass: **88.4 tempered HST laminated with PVB**
total height: **1100 mm**
total width: **1000 mm**

Static tests:

Satisfactory under horizontal inward loads
Satisfactory under horizontal outward loads

Impact tests

Satisfactory in soft body impact tests.
Satisfactory in hard body impact tests.

The Technical Head
Sara Cattaneo

Digitally signed in accordance with current legislation.

Milano headquarter- Material Acceptance and Certification Office
via Celoria, 3 – 20133 Milano – Phone +39 02 2399 4210 Fax +39 02 2399 4211

Lecco headquarter
via Gaetano Previati 1/C – 23900 Lecco – Phone +39 0341/48 8793 Fax +39 0341/48 8771

Official Laboratory (art. 20 Law n. 1086 del 5 November 1971) – NB 1777 Reg. (UE) 305/2011



POLITECNICO
MILANO 1863

LABORATORIO PROVE MATERIALI

Annex 1

Fiche d'identification du vitrage (à remplir par le fabricant de vitrage)

POLIMI #rif. PROVA /CERTIFICATO 08
QUIDAM #rif. I/00643 POS.05

Fiche d'identification du vitrage à renseigner par le fabricant <i>Identification sheet of the glazing to be completed by the manufacturer</i>	
Nom du produit / <i>Product name</i>	CHORUS QUIDAM
Nom du fabricant / <i>Manufacturer name</i>	QUIDAM SRL
Nom de l'usine d'assemblage en feuilleté / <i>Name of assembly plant for laminated glass</i>	STAB. VIA CORTEMILIA, 22/24 17014 CAIRO MONTENOTTE SV (ITA)
Dimensions / <i>Dimensions</i>	1000 x 1075 mm
Verre 1 / <i>Glass 1</i>	
- Épaisseur / <i>Thickness</i>	8 mm
- Traitement thermique / <i>Heat treatment</i>	temp+HST EN 14179
- Façonnage des bords / <i>Edge shaping</i>	JPP/MFL
- Autres (sérigraphie, couches ...) / <i>Others (patterned, coating, ...)</i>	*
- Mesure optique des précontraintes de surface des vitrages trempés ou durcis suivant la norme NF EN 14179 ou NF EN 1863 ou réalisation d'essais de flexion suivant NF EN 1288-3 / <i>measurement of surface compression stress of thermally toughened or heat strengthened glass according to EN 14179 or EN 1863 or bending test according to EN 1288-3</i>	<i>cf. mesure par le laboratoire / cf. misura presa dal laboratorio</i>
Verre 2 / <i>Glass 2</i>	
- Épaisseur / <i>Thickness</i>	8 mm
- Traitement thermique / <i>Heat treatment</i>	temp+HST EN 14179
- Façonnage des bords / <i>Edge shaping</i>	JPP/MFL
- Autres (sérigraphie, couches ...) / <i>Others (patterned, coating, ...)</i>	-
- Mesure de contrainte de compression superficielle des vitrages trempés ou durcis suivant la norme NF EN 14179 ou les essais de flexion suivant NF EN 1288-3 / <i>Optical surface pre-stress measurement of thermally toughened or heat strengthened glass according to EN 14179 or bending test according to EN 1288-3</i>	<i>cf. mesure par le laboratoire / cf. misura presa dal laboratorio</i>
Intercalaire / <i>Interlayer</i>	
- Nom du film / <i>Interlayer name</i>	PVB
- Fabricant / <i>Manufacturer</i>	Eastman
- Nature / <i>Nature</i>	thermoplastic
- Épaisseur / <i>Thickness</i>	1,52 mm
- Date et signature du fournisseur de vitrage / <i>Date and signature of glazing manufacturer</i>	03/05/2022

The Technical Head
Sara Cattaneo

Digitally signed in accordance with current legislation.

Milano headquarter- Material Acceptance and Certification Office
via Celoria, 3 – 20133 Milano – Phone +39 02 2399 4210 Fax +39 02 2399 4211

Lecco headquarter
via Gaetano Previati 1/C – 23900 Lecco – Phone +39 0341/48 8793 Fax +39 0341/48 8771

Official Laboratory (art. 20 Law n. 1086 del 5 November 1971) – NB 1777 Reg. (UE) 305/2011