



**POLITECNICO**  
MILANO 1863

LABORATORIO PROVE MATERIALI

Spett. le

LOGLI MASSIMO S.P.A.  
VIA CHEMNITZ 49/51  
59100 PRATO (PO) - ITA

**Test report N. 2023/0741 issued in Milan il 08/03/2023**

Applicant: LOGLI MASSIMO S.P.A.- PRATO (PO) – ITALIA

Samples arrival date: -

## TEST REPORT

Test of railing systems for glass balustrades

In following pages are reported:

- References to data from original test reports;
- Data evaluation according to British Standard 6180:2011.

**The test results apply only to the tested samples.**

**This Test Report consists of 11 pages.**

**This Test Report can be reproduced only integrally and shall be subjected to duty stamp for use according to Italian Law D.P.R. 642/72.**

**THE SERVICE HEAD**

**Roberto Minerva**

Digitally signed in accordance with current legislation.

**Milano headquarter- Material Acceptance and Certification Office**  
via Celoria, 3 – 20133 Milano – Phone +39 02 2399 4210 Fax +39 02 2399 4211

**Lecco headquarter**  
via Gaetano Previati 1/C – 23900 Lecco – Phone +39 0341/48 8793 Fax +39 0341/48 8771

*Official Laboratory (art. 20 Law n. 1086 del 5 November 1971) – NB 1777 Reg. (UE) 305/2011*



## 1. INTRODUCTION

Tests were commissioned by the client, Logli Massimo SpA, to evaluate the performance of several balustrade assemblies using different “DEFENDER” railing systems, in combination with laminated glass panels. The testing procedure included a continuous measurement of horizontal displacement on the handrail (upper edge of the glass panel) as a function of a horizontally imposed increasing linear load according to the test procedure described in the Italian Standard UNI 11678:2017.

Results within these certificates are hereby examined in accordance to BS 6180:2011 Barriers in and about Buildings – Code of Practice to allow these balustrade systems to be classified for use in accordance with the Code of Practice included within said Standard.

Detailed results for each and every configuration evaluated are described in detail in the following test certificates issued by our laboratory:

- Test certificate N.2022/2169 issued July the 28<sup>th</sup> 2022
- Test certificate N.2022/2170 issued July the 28<sup>th</sup> 2022
- Test certificate N.2022/2171 issued July the 28<sup>th</sup> 2022
- Test certificate N.2022/2172 issued July the 28<sup>th</sup> 2022
- Test certificate N.2022/3552 issued February the 7<sup>th</sup> 2023
- Test certificate N.2022/3553 issued February the 7<sup>th</sup> 2023
- Test certificate N.2022/3956 issued February the 7<sup>th</sup> 2023
- Test certificate N.2022/3957 issued February the 7<sup>th</sup> 2023

This evaluation report summarizes without interpretation relevant test results obtained within the aforementioned individual test certificates. Results given in this evaluation report only apply to the samples that have been tested.

## 2. TEST SAMPLES

The tested assemblies all include an aluminium rail with a U-shaped part, which is anchored to a load-bearing structure and is used to secure laminated glass (LG) panels, by means of plastic clamps. The described assemblies are intended to be used as balustrades.

Table 1 contains an overview of the evaluated systems within this report, depending on the mount type and thickness of the LG panels installed.

Balustrades were tested installed on C20/25 concrete elements, casted according to TR048 – EOTA -2016.

For additional details about the test samples identification, refer to the individual certificates listed in §1 and cross-referenced in Table 4 page 8.

Digitally signed in accordance with current legislation.

**Milano headquarter- Material Acceptance and Certification Office**  
via Celoria, 3 – 20133 Milano – Phone +39 02 2399 4210 Fax +39 02 2399 4211

**Lecco headquarter**  
via Gaetano Previati 1/C – 23900 Lecco – Phone +39 0341/48 8793 Fax +39 0341/48 8771

*Official Laboratory (art. 20 Law n. 1086 del 5 November 1971) – NB 1777 Reg. (UE) 305/2011*

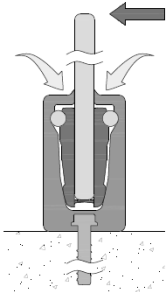
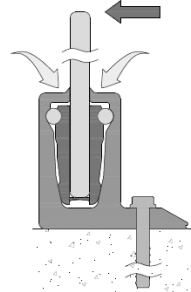
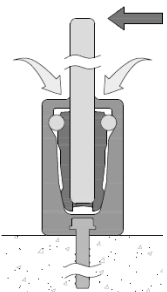
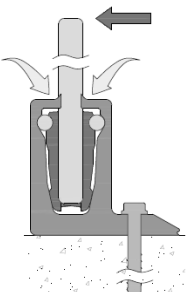
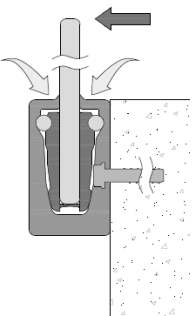
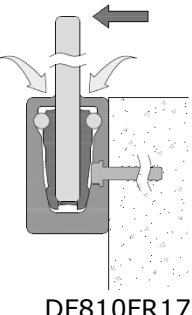

Table 1 - list of systems per mount type and glass panel thickness

Mount type	glass thickness	Schemes and references of systems within this report
top mount	8+8	 <p>DF810LM17</p>  <p>DF810DK17</p>
	10+10	 <p>DF810LM21</p>  <p>DF810DK17</p>
lateral mount	8+8	 <p>DF810FR17</p>
	10+10	 <p>DF810FR17</p>

Digitally signed in accordance with current legislation.

**Milano headquarter- Material Acceptance and Certification Office**  
via Celoria, 3 – 20133 Milano – Phone +39 02 2399 4210 Fax +39 02 2399 4211

**Lecco headquarter**  
via Gaetano Previati 1/C – 23900 Lecco – Phone +39 0341/48 8793 Fax +39 0341/48 8771

Official Laboratory (art. 20 Law n. 1086 del 5 November 1971) – NB 1777 Reg. (UE) 305/2011



## 2.1 RAILING SYSTEMS

All railing systems tested use AW 6063 T6 aluminium profiles, extruded according to EN 573 and EN 755-2. These profiles are predrilled depending on the mount type with equally spaced holes for top mount or lateral mount installations.

The systems use plastic clamps (polyoxymethylene), provided with wedges (polyphthalamide) which are allowed to move via a stainless steel M6 screw. Such clamps are used to secure the LG panels within the U shaped parts of the aluminium profiles. Nowhere within the system the glass is put in contact with metal parts. Additional clip-on aluminium profiles are used to provide external cover to clamping mechanism once the LG panel is secured in place. Sealing gaskets (thermoplastic elastomers) are used at the interface between the aluminium extruded parts and the glass surface at the exit of the system.

Details of all parts comprising each DEFENDER system reference within this evaluation report are given in the figures referenced within the following Table 2. For additional details, refer to the individual certificates listed in §1 cross-referenced in Table 4 page 8.

Table 2 - “DEFENDER” aluminium railing systems details

<b>DEFENDER system reference</b>	<b>height of the aluminium system [mm]</b>	<b>width of the aluminium system [mm]</b>	<b>pre-drilled holes spacing [mm]</b>	<b>depth of the glass within the system [mm]</b>	<b>Ref.</b>
DF810LM17	120	72	20	95	Figure 3 page 9
DF810LM21	120	72	20	95	Figure 4 page 9
DF810DK17	120	132	20	95	Figure 5 page 10
DF810DK21	120	132	20	95	Figure 6 page 10
DF810FR17	127	74	20	95	Figure 7 page 11
DF810FR21	127	74	20	95	Figure 8 page 11

## 2.2 ANCHORS

Anchors were selected according to the profile for installation on concrete structure. The following have been used throughout different tests: FISCHER FBS under (ETA-11/0095).

Details about anchors installed for each individual assembly are referred to in the individual certificates listed in §1 and cross-referenced in Table 4 page 8.

## 2.3 GLASS PANELS

LG panels were assembled using different types of glass plies, depending on thermal treatment used before lamination: EN 572 for annealed float glass, EN 1863 for heat-strengthened plies, EN 12150 for thermally tempered plies.

LG plies were then assembled during lamination using different interlayers for different assemblies. Interlayers used were: standard PVB, SentryGlas®.

Digitally signed in accordance with current legislation.

**Milano headquarter- Material Acceptance and Certification Office**  
via Celoria, 3 – 20133 Milano – Phone +39 02 2399 4210 Fax +39 02 2399 4211

**Lecco headquarter**  
via Gaetano Previati 1/C – 23900 Lecco – Phone +39 0341/48 8793 Fax +39 0341/48 8771

Official Laboratory (art. 20 Law n. 1086 del 5 November 1971) – NB 1777 Reg. (UE) 305/2011



Table 3 - Laminated Glass compositions reference

Laminated glass composition reference	Glass panes thickness [mm]	Glass panes type	Interlayer	Interlayer thickness [mm]
88.2 H PVB	8+8	Tempered + heat strengthened*	PVB	0.76
88.4 T SG	8+8	tempered	SentryGlas®	1.52
1010.2 H PVB	10+10	Tempered + heat strengthened*	PVB	0.76
1010.4 T SG	10+10	tempered	SentryGlas®	1.52

\* this composition was tested with the tempered glass pane facing the inner part of the barrier

For all additional details the origin and properties of every glass panel, refer to the individual certificates listed in §1 cross-referenced in Table 4 page 8

### 3. INSTALLATION OF THE SPECIMEN

Specimens were installed according to instructions and under the supervision of personnel from the company Logli Massimo. The following procedure was used:

1. Checking of the correct position of the concrete block with a level,
2. marking of the holes to be drilled on the concrete block using the pre-drilled aluminium profile as template,
3. drilling of the slab at an embedment depth according to the anchors of choice for each individual assembly.
4. cleaning of the dust within drilled holes,
5. installation of the main aluminium profile using the appropriate anchors (cf. §1),
6. tightening of the anchors to a maximum torque as recommended per supplier instructions,
7. assembly and positioning of plastic clamps with spacing detailed in Table 4,
8. inserting the LG panel in the system,
9. adjustment of the tilt to vertical position and tightening of the clamps,
10. installation of gaskets onto the clip-on profiles and sealing of the system (optional).

For additional details on the installation of different assemblies, refer to the individual certificates listed in §1 cross-referenced in Table 4 page 8

### 4. SET-UP AND METHODOLOGY

Static tests were performed within a broader campaign, which also included dynamic tests according to relevant national standards. Dynamic tests are not taken into account within this evaluation report, as these results have no impact concerning the classification within the Code of Practice in accordance to BS 6180:2011 Standard.

Static test were performed to simulate a distributed line load acting from inside to outside by means of four pneumatic jacks, attached to the strong floor. These pneumatic jacks can apply a uniform and controlled load via four ties attached to the upper edge of the balustrade, fixed with regular spacing according to the width of each specimen, to simulate the load from inside to outside. Sketches and examples of the setup are shown in Figure 1 and Figure 2.

Digitally signed in accordance with current legislation.

**Milano headquarter- Material Acceptance and Certification Office**  
via Celoria, 3 – 20133 Milano – Phone +39 02 2399 4210 Fax +39 02 2399 4211

**Lecco headquarter**  
via Gaetano Previati 1/C – 23900 Lecco – Phone +39 0341/48 8793 Fax +39 0341/48 8771

Official Laboratory (art. 20 Law n. 1086 del 5 November 1971) – NB 1777 Reg. (UE) 305/2011

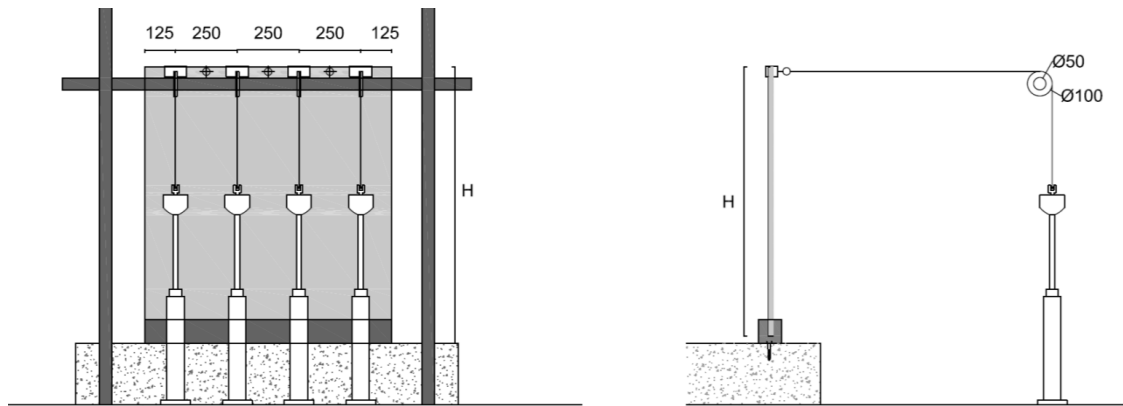

Figure 1 - scheme of the test setup



Figure 2 - Test setup for top mount balustrades, example from Test certificate 2022/2169

Digitally signed in accordance with current legislation.

**Milano headquarter- Material Acceptance and Certification Office**  
via Celoria, 3 – 20133 Milano – Phone +39 02 2399 4210 Fax +39 02 2399 4211

**Lecco headquarter**  
via Gaetano Previati 1/C – 23900 Lecco – Phone +39 0341/48 8793 Fax +39 0341/48 8771

Official Laboratory (art. 20 Law n. 1086 del 5 November 1971) – NB 1777 Reg. (UE) 305/2011



#### 4.1 DATA ACQUISITION

The applied load of each of the four hydraulic jacks was monitored via load cell (AEP TC4 S.N. 430971 -400896 – 715249 – 440041, class 1).

The load measured by the load cells was acquired by control system PLC Siemens S7 with specific software designed to maintain a uniform load in the four points.

The displacements were measured with three wire transducers WAYCON SX50-750-1R-KA02, placed horizontally at the height of the load application, on the opposite side, at midspan (S.N. 17555215) and at one third the width both on the right (S.N. 17555213) and on the left (S.N. 18561245).

Data from the load cells and from the wire displacement transducers was continuously acquired by Spider 8 HBM data acquisition system with specimen frequency of 2 Hz.

For each test, the ambient temperature and the relative humidity were monitored and registered using Extech Instrument RH520 Temperature and Humidity Recorder.

#### 4.2 TESTING PROCEDURE

The load was applied in incremental steps, depending on the load class required for relevant standards (both the reference standard and load class are referenced in each certificate listed in §1 cross-referenced in Table 4 page 8). Accordingly, each incremental step includes a quasi-static increasing load distributed linearly on top of the balustrade, a load permanence period at maximum load value and a rapidly decreasing unloading ramp.

Most certificates referenced within this evaluation report include multiple load cycles depending on the load class and the standard. Each cycle is composed by a loading ramp, a stationary load interval and an unloading ramp, (such reset is generally required after a pre-loading phase, as defined by the testing procedures). Under the requirements of BS 6180:2011, evaluation of the performance of the balustrades within this evaluation report is made by measuring the maximum horizontal displacement the first time each incremental line load step is reached (as if only one load ramp had been applied).

#### 5. RESULTS

Data from the test certificates listed in §1 cross-referenced in Table 4 page 8 was evaluated in accordance with the guidance given in BS 6180 Barriers in and about Buildings – Code of Practice.

The standard states that the maximum allowable deflection for a glass protective barrier panel is 25 mm.

Horizontal uniformly distributed line load measured to reach maximum allowable deflection for the balustrade assemblies tested are given in Table 4 page 8.

Table 2 of BS 6180 categorizes parapets, barriers, and balustrades for areas of use depending on the loads which have to be applied to produce this maximum allowable deflection. Depending on the type of occupancy for a building, limits for horizontal uniformly distributed line load are 0.22 kN/m, 0.36 kN/m, 0.74 kN/m, 1.50, kN/m and 3.0 kN/m. Such limits are defined in BS 6180 by means of fifteen examples according to various types of occupancies (these are numbered from (i) to (vx), detailing different uses of barriers for domestic and residential activities, offices, areas where people might congregate with or without fixed obstacles, susceptible or not to overcrowding, etc.).

Digitally signed in accordance with current legislation.

**Milano headquarter- Material Acceptance and Certification Office**  
via Celoria, 3 – 20133 Milano – Phone +39 02 2399 4210 Fax +39 02 2399 4211

**Lecco headquarter**  
via Gaetano Prevati 1/C – 23900 Lecco – Phone +39 0341/48 8793 Fax +39 0341/48 8771

*Official Laboratory (art. 20 Law n. 1086 del 5 November 1971) – NB 1777 Reg. (UE) 305/2011*



Table 5 page 8 summarizes the suitability of the tested balustrade systems with regards of horizontal uniformly distributed line loads limits, as these are described in BS6180:2011.

Results given in this report apply only to the samples that have been tested.

Table 4 - details of all assemblies evaluated and results obtained according to BS 6180:2011

assembly reference	Certificate number	DEFENDER railing system					Laminated glass panel	Line load when reaching 25 mm horizontal displacement [kN/m]
		name	mount	protection height H <sup>1</sup> [cm]	clamps spacing [cm]	anchors spacing (cm)		
01	2022/2169	DF810LM17	top	110	25	40	88.2 H PVB	0,99
02	2022/2170	DF810LM17	top	110	25	20	88.4 T SG	1,65
03	2022/2171	DF810LM21	top	110	25	20	1010.2HPVB	1,52
04	2022/2172	DF810LM21	top	122	25	20	1010.4 T SG	1,50
05	2022/3956	DF810DK17	top	122	25	60	88.2 H PVB	1,00
06	2022/3957	DF810DK21	top	122	25	40	1010.4 T SG	1,61
07	2022/3552	DF810FR17	lateral	110	25	40	88.2 H PVB	1,12
08	2022/3553	DF810FR21	lateral	110	25	20	1010.4 T SG	1,72

Table 5 - Suitability DEFENDER balustrade systems under line load in accordance with BS 6180:2011 minimum horizontal imposed loads requirements

Balustrade assembly identification				Suitability per type of occupancy for part of the building				
Reference within this document	DEFENDER system reference	laminated glass reference	Protection height H <sup>2</sup> [cm]	(iii)	(i) (iv)	(ii) (v) (viii) (ix)	(vi) (vii) (x) (xiii) (xiv)	(xi)
				0.22 kN/m	0.36 kN/m	0.74 kN/m	1.50 kN/m	3.0 kN/m
01	DF810LM17	88.2 H PVB	110	✓	✓	✓		
02	DF810LM17	88.4 T SGz	110	✓	✓	✓	✓	
03	DF810LM21	1010.2HPVB	110	✓	✓	✓	✓	
04	DF810LM21	1010.4 T SG	122	✓	✓	✓	✓	
05	DF810DK17	88.2 H PVB	122	✓	✓	✓		
06	DF810DK21	1010.4 T SG	122	✓	✓	✓	✓	
07	DF810FR17	88.2 H PVB	110	✓	✓	✓		
08	DF810FR21	1010.4 T SG	110	✓	✓	✓	✓	

<sup>1</sup> The height of the protection is measured differently for top-mount or lateral mount installations: see Table 1 page 4 for reference on the protection height H for all systems.

<sup>2</sup> The height of the protection is measured differently for top-mount or lateral mount installations: see Table 1 page 4 for reference on the protection height H for all systems.

Digitally signed in accordance with current legislation.

**Milano headquarter- Material Acceptance and Certification Office**

via Celoria, 3 – 20133 Milano – Phone +39 02 2399 4210 Fax +39 02 2399 4211

**Lecco headquarter**

via Gaetano Previati 1/C – 23900 Lecco – Phone +39 0341/48 8793 Fax +39 0341/48 8771

Official Laboratory (art. 20 Law n. 1086 del 5 November 1971) – NB 1777 Reg. (UE) 305/2011



**POLITECNICO**  
MILANO 1863

LABORATORIO PROVE MATERIALI

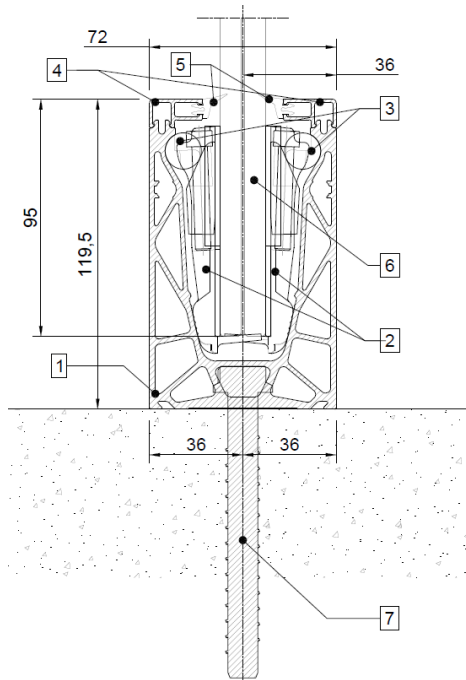

- 1 base profile [ref. DF810LM.60]
- 2 clamps made with two identical L shaped elements assembled to form a U shaped clamp [ref. DF1721]
- 3 contact roller between the clamps and the base profile [part of ref. DF2121]
- 4 clip-on profiles with rail for gasket installation [ref. DF100]
- 5 gaskets [ref. DFP88G01]
- 6 laminated glass 8.8/x
- 7 anchor to main structure (example on concrete)

Figure 2 – Scheme of the DEFENDER system DF810LM17

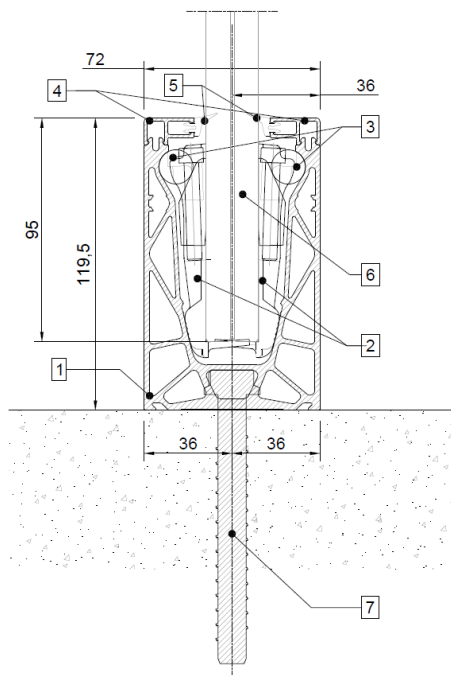

- 1 base profile [ref. DF810LM.60]
- 2 clamps made with two identical L shaped elements assembled to form a U shaped clamp [ref. DF2121]
- 3 contact roller between the clamps and the base profile [part of ref. DF2121]
- 4 clip-on profile with rail for gasket installation [ref. DF100]
- 5 Gaskets [ref. DFP88G01]
- 6 Laminated glass 10.10/x
- 7 anchor to main structure (example on concrete)

Figure 3 – Scheme of the DEFENDER system DF810LM21

Technical Head  
Sara Cattaneo

Digitally signed in accordance with current legislation.

**Milano headquarter- Material Acceptance and Certification Office**  
via Celoria, 3 – 20133 Milano – Phone +39 02 2399 4210 Fax +39 02 2399 4211

**Lecco headquarter**  
via Gaetano Previati 1/C – 23900 Lecco – Phone +39 0341/48 8793 Fax +39 0341/48 8771

Official Laboratory (art. 20 Law n. 1086 del 5 November 1971) – NB 1777 Reg. (UE) 305/2011



**POLITECNICO**  
MILANO 1863

LABORATORIO PROVE MATERIALI

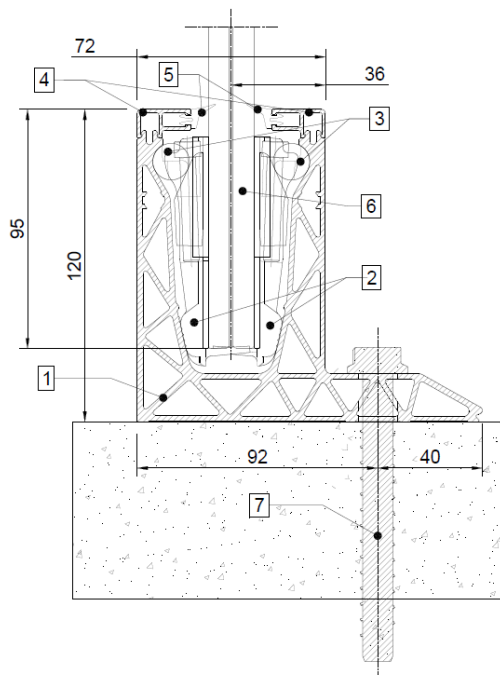

- 1 base profile [ref. DF810DK.60]
- 2 clamps made with two identical L shaped elements assembled to form a U shaped clamp [ref. DF1721]
- 3 contact roller between the clamps and the base profile [part of ref. DF1721]
- 4 clip-on profile with rail for gasket installation [ref. DF100]
- 5 Gaskets [ref. DFP88G01]
- 6 Laminated glass 8.8/x
- 7 anchor to main structure (example on concrete)

Figure 5 – Scheme of the DEFENDER system DF810DK17

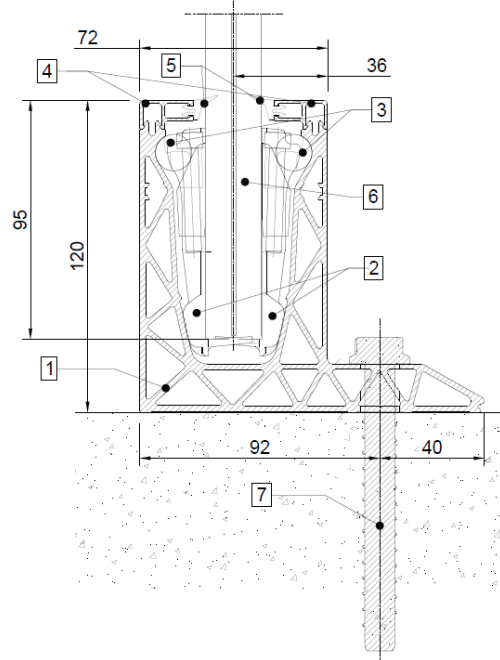

- 1 base profile [ref. DF810DK.60]
- 2 clamps made with two identical L shaped elements assembled to form a U shaped clamp [ref. DF2121]
- 3 contact roller between the clamps and the base profile [part of ref. DF2121]
- 4 clip-on profile with rail for gasket installation [ref. DF100]
- 5 Gaskets [ref. DFP88G01]
- 6 Laminated glass 10.10/x
- 7 anchor to main structure (example on concrete)

Figure 6 – Scheme of the DEFENDER system DF810DK21

Technical Head  
Sara Cattaneo

Digitally signed in accordance with current legislation.

**Milano headquarter- Material Acceptance and Certification Office**  
via Celoria, 3 – 20133 Milano – Phone +39 02 2399 4210 Fax +39 02 2399 4211

**Lecco headquarter**  
via Gaetano Previati 1/C – 23900 Lecco – Phone +39 0341/48 8793 Fax +39 0341/48 8771

Official Laboratory (art. 20 Law n. 1086 del 5 November 1971) – NB 1777 Reg. (UE) 305/2011



**POLITECNICO**  
MILANO 1863

LABORATORIO PROVE MATERIALI

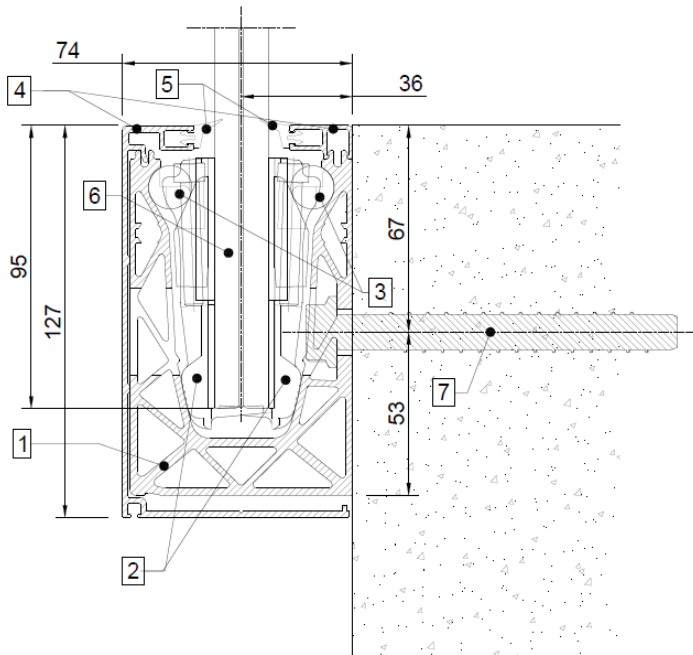

- 1 base profile [ref. DF810FR.60]
- 2 clamps made with two identical L shaped elements assembled to form a U shaped clamp [ref. DF1721]
- 3 contact roller between the clamps and the base profile [part of ref. DF1721]
- 4 clip-on profiles with rail for gasket installation [ref. DF100 & DFS15]
- 5 gaskets [ref. DFP88G01]
- 6 laminated glass 8.8/x
- 7 anchor to main structure (example on concrete)

Figure 4 – Scheme of the DEFENDER system DF810FR17

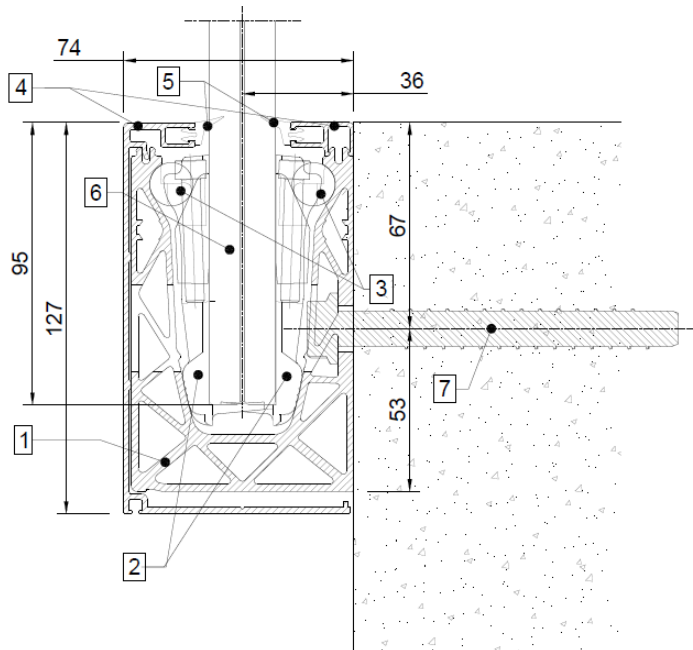

- 1 base profile [ref. DF810FR.60]
- 2 clamps made with two identical L shaped elements assembled to form a U shaped clamp [ref. DF2121]
- 3 contact roller between the clamps and the base profile [part of ref. DF2121]
- 4 clip-on profile with rail for gasket installation [ref. DF100 & DFS15]
- 5 Gaskets [ref. DFP88G01]
- 6 Laminated glass 10.10/x
- 7 anchor to main structure (example on concrete)

Figure 5 – Scheme of the DEFENDER system DF810FR21

Technical Head  
Sara Cattaneo

Digitally signed in accordance with current legislation.

**Milano headquarter- Material Acceptance and Certification Office**  
via Celoria, 3 – 20133 Milano – Phone +39 02 2399 4210 Fax +39 02 2399 4211

**Lecco headquarter**  
via Gaetano Previati 1/C – 23900 Lecco – Phone +39 0341/48 8793 Fax +39 0341/48 8771

Official Laboratory (art. 20 Law n. 1086 del 5 November 1971) – NB 1777 Reg. (UE) 305/2011