

GAMME
PROFIL IMBOTTE
MANUEL TECHNIQUE



LOGLI
MASSIMO®
glass system technology

2.1 04/2017



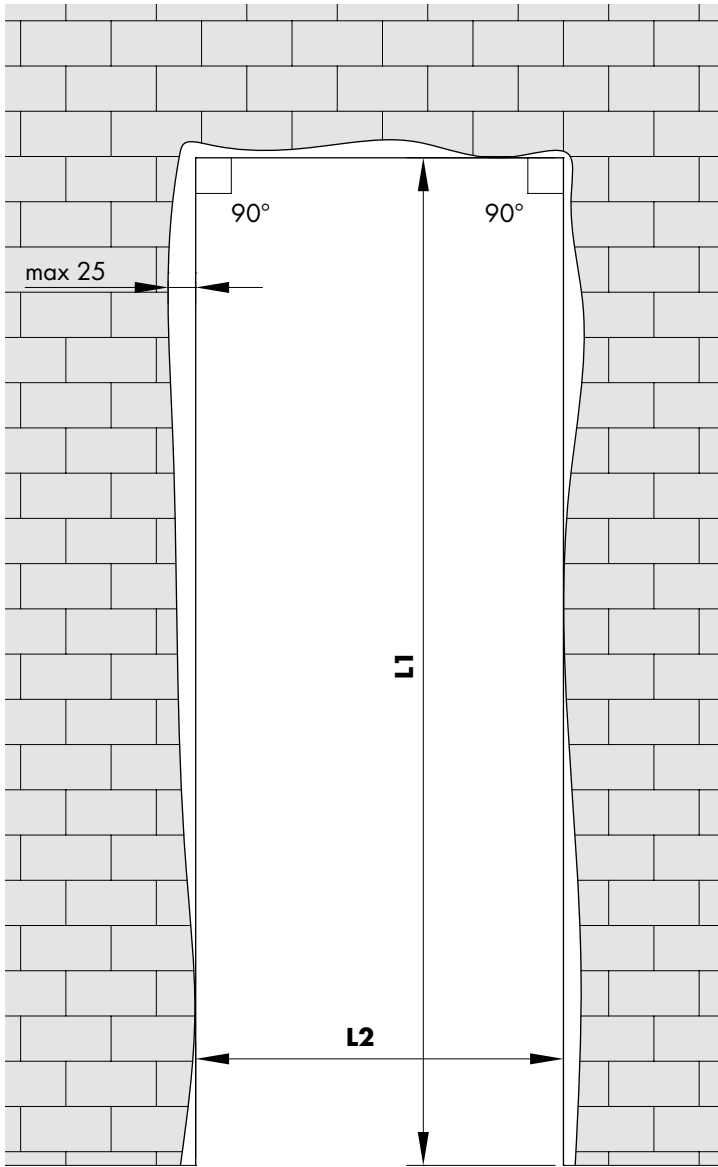

Dimensions et tolérances ouverture porte

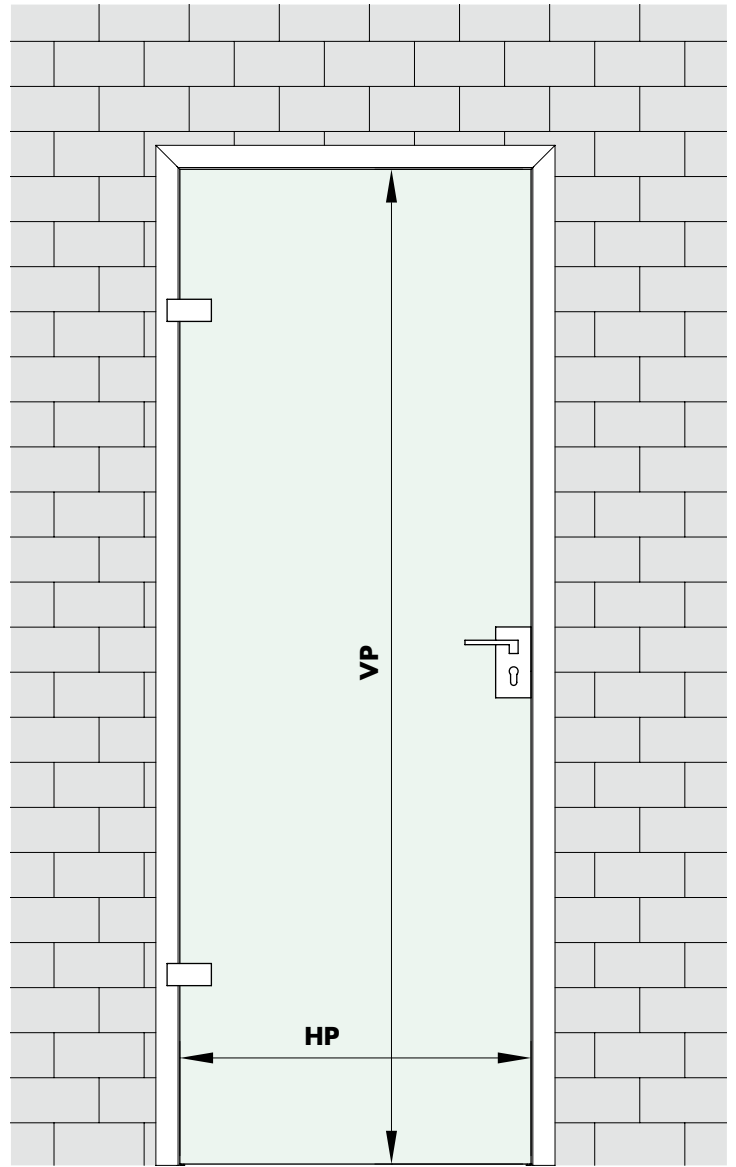

Dimensions du vantail en verre

$$HP = L2 - 2G - 2A - 20mm$$

$$VP = L1 - G - 2A - 10mm$$

G = jeu minimum désiré entre paroi et imbotte

A = espace prévu entre imbotte et vantail en verre

* pour compenser le jeu **G** nous conseillons l'utilisation d'épaisseurs: SPE2402/03/04/05/06/07

Sauf indication contraire:

G = 3mm et **A** = 4mm

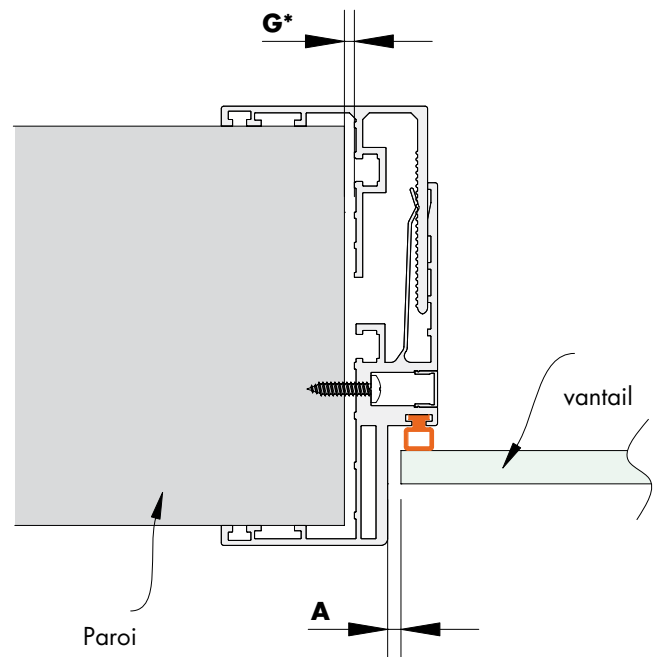

SÉQUENCE MONTAGE PROFILS

•1

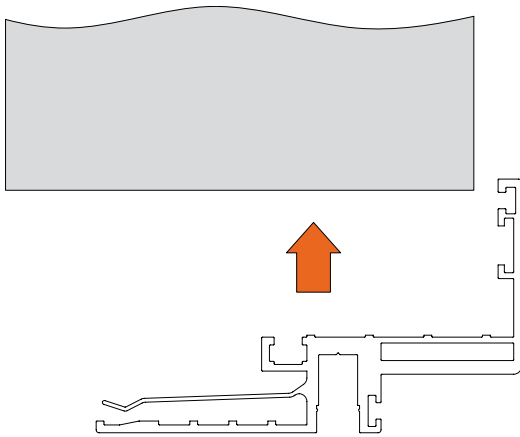

•2

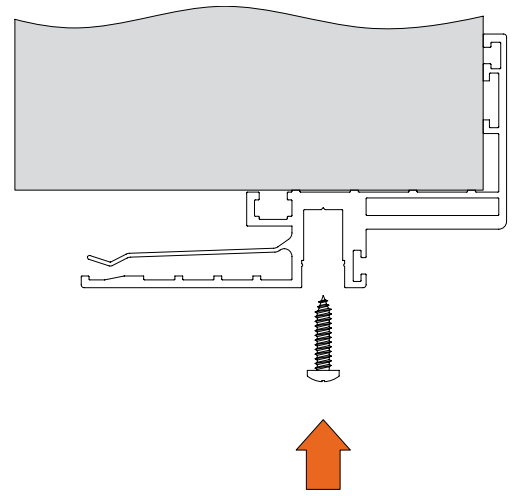

•3

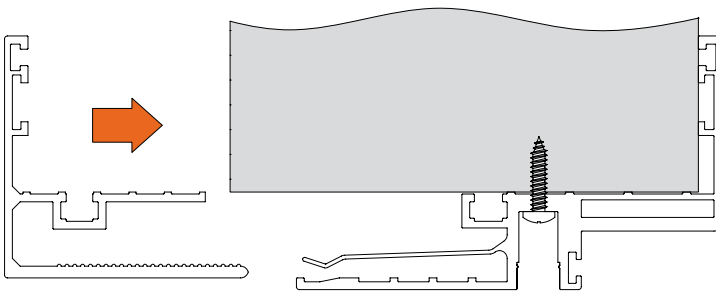

•4

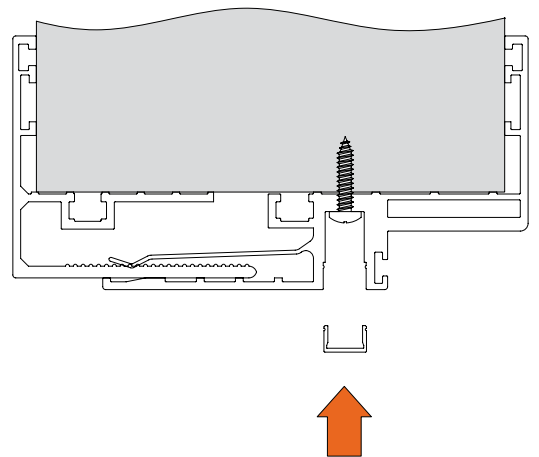

•5

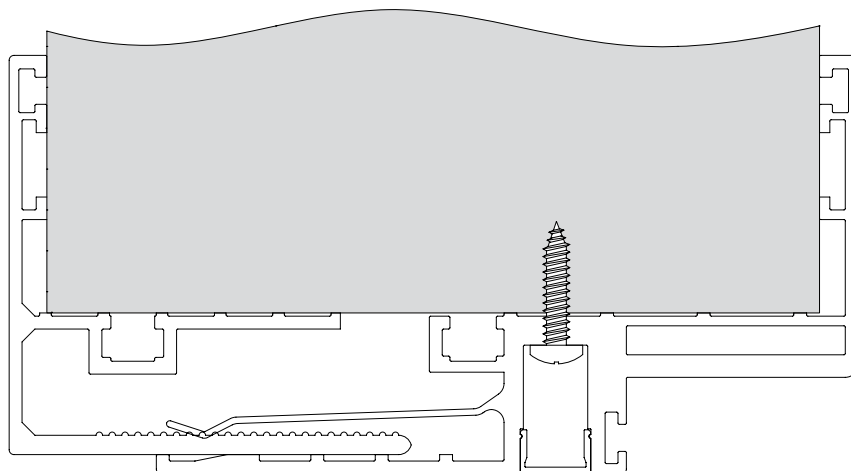

ÉTAPE 1 : Insérer les joints dans les emplacements prévus à cet effet

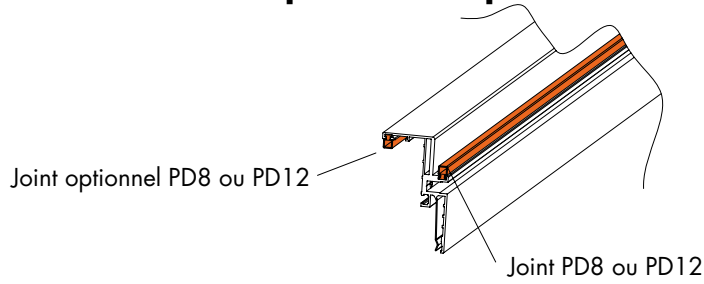

ÉTAPE 2 : Montage des profils portants

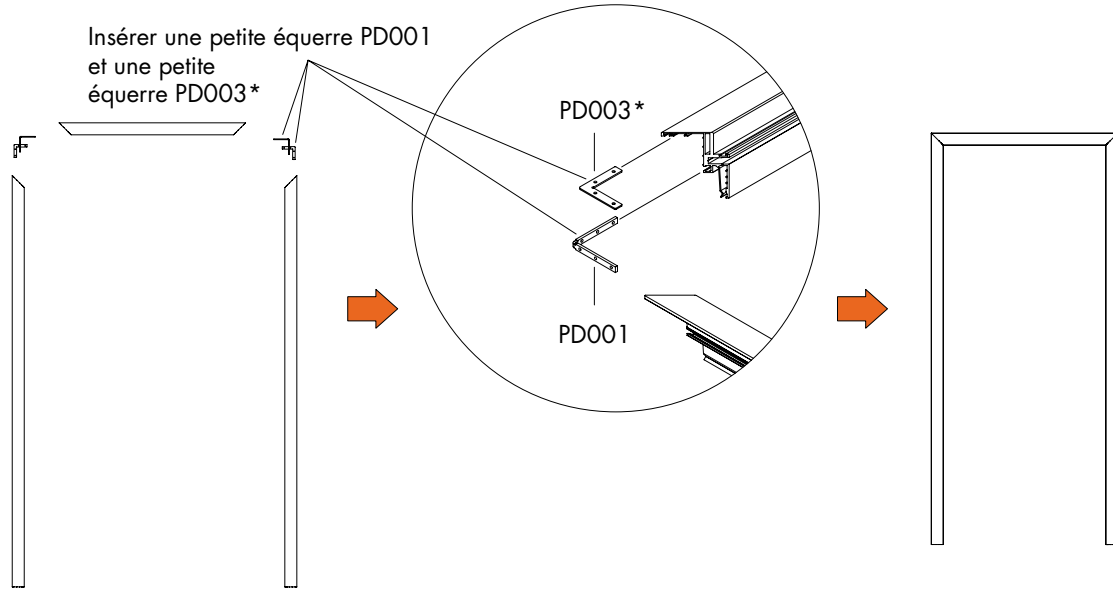

* Couple de serrage tiges = 0,4 Nm

ÉTAPE 3 : Montage de l'intrados portant sur la paroi

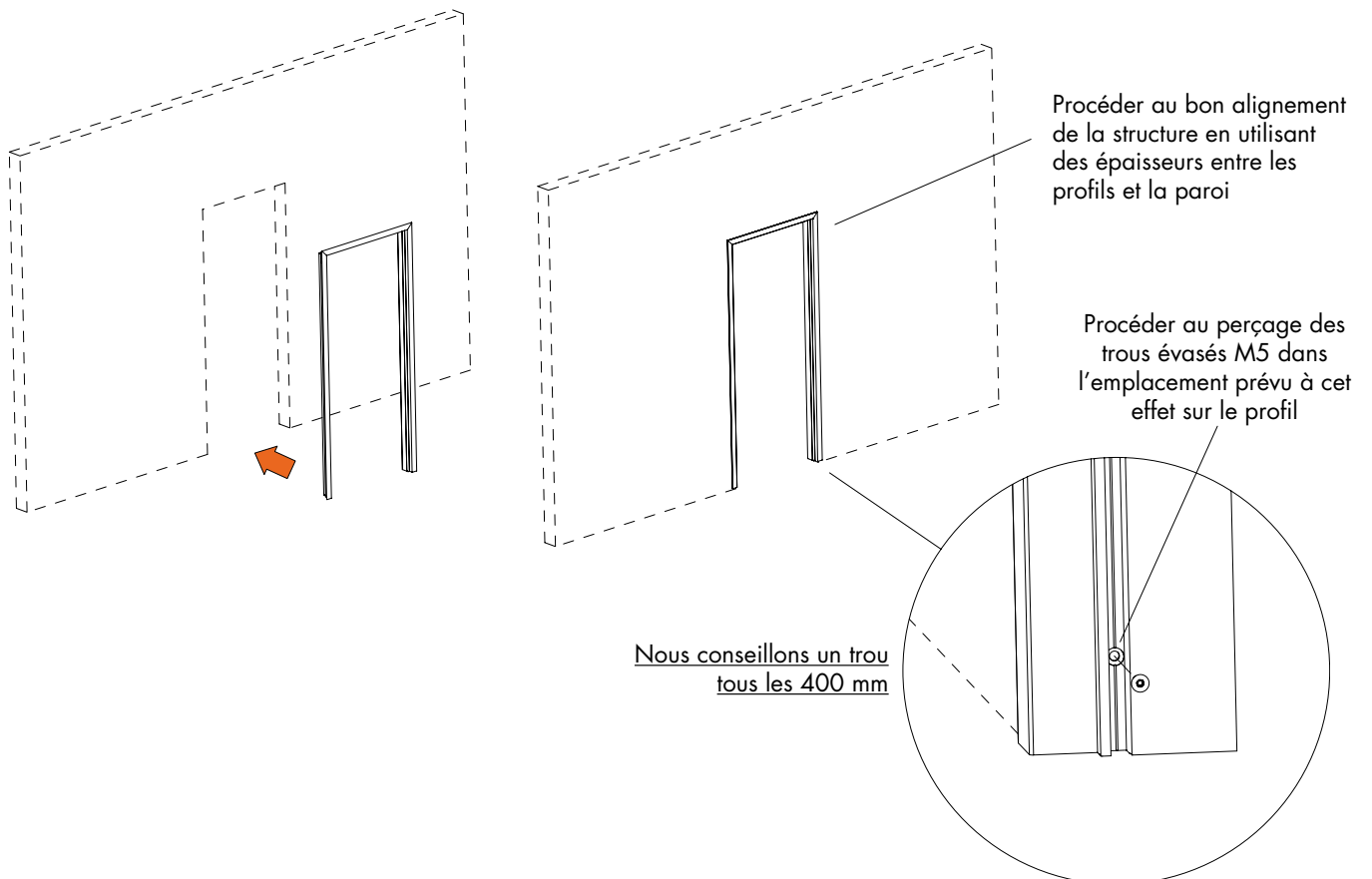

ÉTAPE 4 : Montage des profils postérieurs de fermeture

Insérer une petite équerre PD001 et une petite équerre PD003*

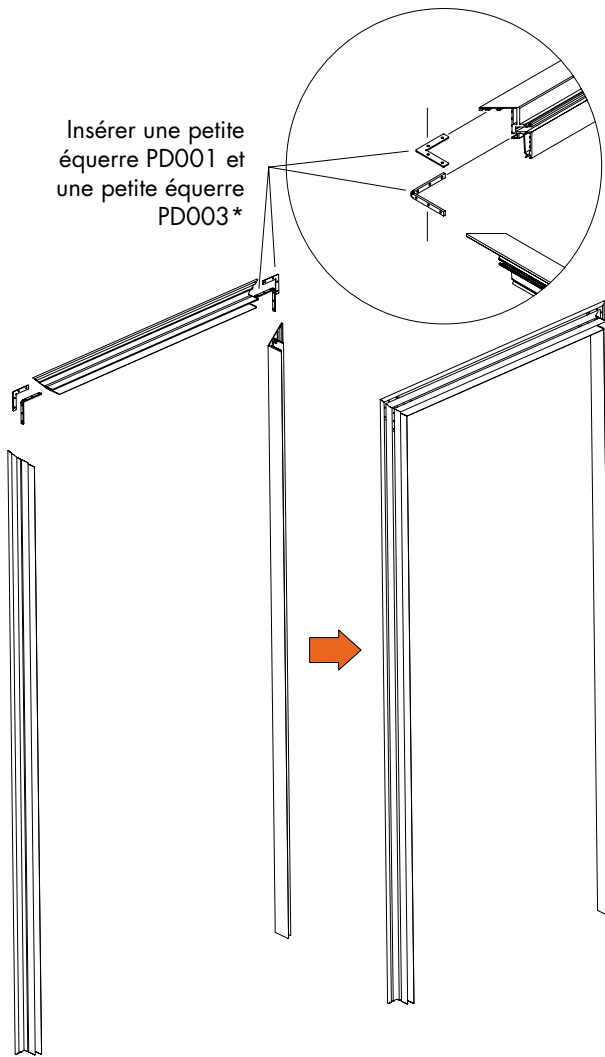

* Couple de serrage tiges = 0,4 Nm

ÉTAPE 5 : Insérer le profil postérieur de fermeture sur le profil antérieur

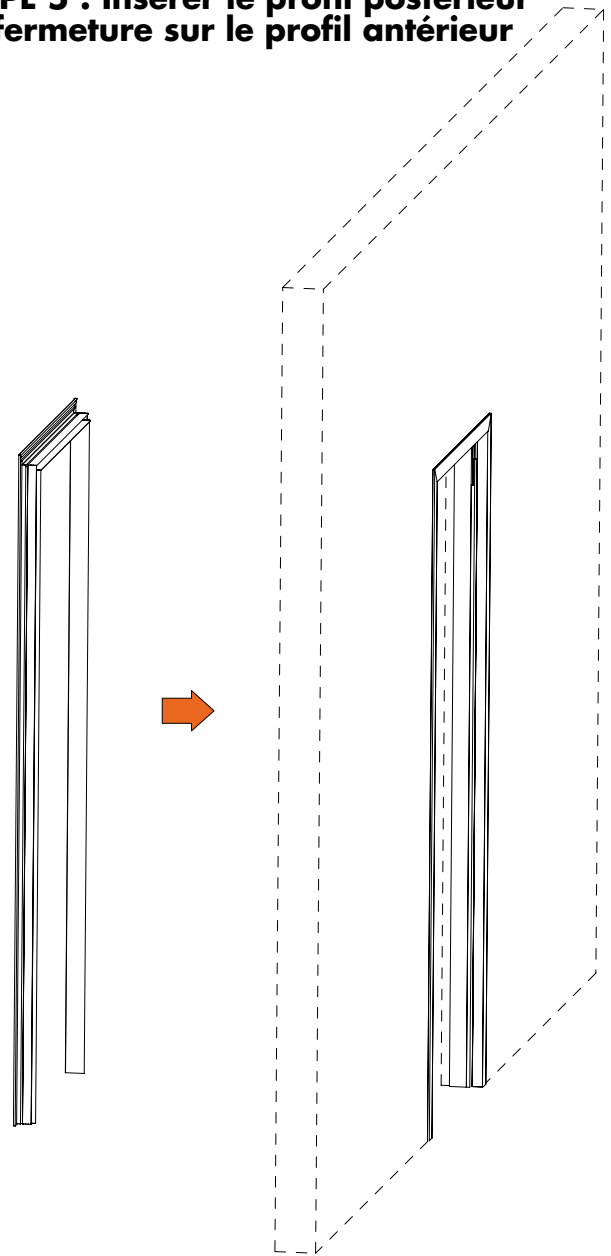

ÉTAPE 6 : Insérer le cache de finition par encastrement

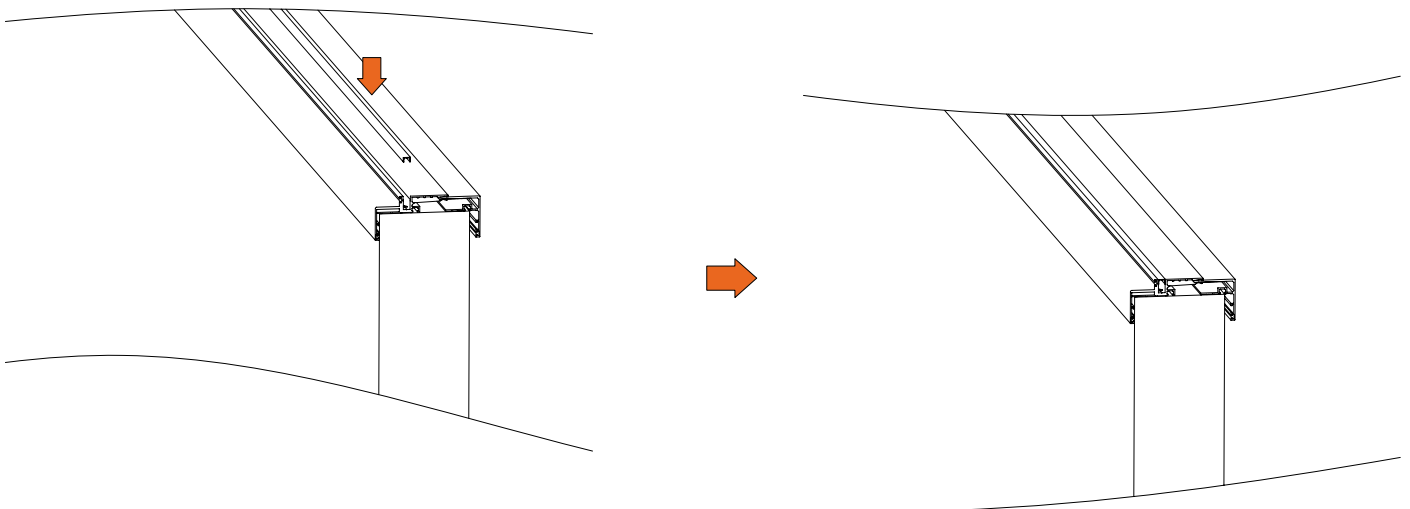

Les images et les informations contenues dans ce catalogue
sont fournies à titre indicatif et peuvent être modifiées
à tout moment et sans préavis



LOGLI MASSIMO SpA
Via Chemnitz, 49/51 - 59100 Prato - Italie
Tel. +39.0574.701035 Fax +39.0574.527574
www.loglimassimo.it - info@loglimassimo.it

SPONSOR



ASSOCIATED PARTNERS

