



POLITECNICO
MILANO 1863

LABORATORIO PROVE MATERIALI

Spett.le
LOGLI MASSIMO S.P.A.
VIA CHEMNITZ 49/51
59100 PRATO (PO) - ITA

Test report N. 2020/2379 issued in Milan 14/10/2020

Client: LOGLI MASSIMO S.P.A.- PRATO (PO) – ITALIA

Specimen entry: 05/10/2020

TEST REPORT

Test on glass balustrade

In the following pages are reported:

- Specimen description and test procedure;
- Test results.

The results are related only to the tested specimens.

The test report consists of 15 pages.

The test report can be only completely reproduced in full and shall be subjected to stamp duty for use according to Italian law D.P.R. 642/72.

THE SERVICE HEAD

Roberto Minerva

Sede di Milano - Ufficio Accettazione materiale e Certificazione
via Celoria, 3 – 20133 Milano – Tel. 02 2399 4210 Fax 02 2399 4211

Sede di Lecco
via Gaetano Previati 1/C – 23900 Lecco – Tel. 0341/48 8793 Fax 0341/48 8771

INDEX

1. Introduction
2. Reference standards
3. Specimen identification
4. Test procedure
5. Test results
6. Conclusions

1. INTRODUCTION

This test report presents the results of static tests on glass balustrades according to the reference standard (UNI11678:2017 and Cahier du CSTB 3034_V3).

Tests were performed at LPMSC (Materials, Structures and Constructions Laboratory) of Politecnico di Milano on the 08/10/2020 at the presence of the following persons:

Mr Daniele Spinelli (Politecnico di Milano)

Prof. Eng. Ph.D. Sara Cattaneo (Politecnico di Milano)

Eng. Ph.D. Lorenzo Piscitelli (Logli Massimo S.p.A.)

2. REFERENCE STANDARDS

UNI 11678:2017 - Vetro per edilizia - Elementi di tamponamento in vetro aventi funzione anticaduta - Resistenza al carico statico lineare ed al carico dinamico - Metodi di Prova

Cahier du CSTB 3034_V3- Garde-corps non traditionnels en produits verriers encastrés en pied

3. SPECIMEN IDENTIFICATION

Two laminated glass specimens (one for static test and one for impact test) made of two glass plies of 12 mm (both tempered) were considered to perform static test and impact test, joined through 1.52 mm sentryglas® ionoplast interlay by KURARAY Co.,LTD. The glass specimen provided by the company Quidam s.r.l. commissioned by the client comply with EN 14179 and EN 14449.

Glass specimens had dimension of 0.5m x 1.075m (height of the balustrade from the floor 1.1m) and were installed with the system “DEFENDER DF1012LM”, with a length of 0.5m. The system uses aluminium profiles AW 6063 T6, extruded according to EN 573 and EN 755-2, with holes at the bottom and named “DF1012LM”. One profile was

The Technical Head
Sara Cattaneo

Digitally signed in accordance with current legislation.

Milano headquarter- Material Acceptance and Certification Office
via Celoria, 3 – 20133 Milano – Phone +39 02 2399 4210 Fax +39 02 2399 4211

Lecco headquarter
via Gaetano Previati 1/C – 23900 Lecco – Phone +39 0341/48 8793 Fax +39 0341/48 8771

Official Laboratory (art. 20 Law n. 1086 del 5 November 1971) – NB 1777 Reg. (UE) 305/2011



POLITECNICO
MILANO 1863

LABORATORIO PROVE MATERIALI

used for static tests and a second identical profile was used for impact tests. The tested profiles both had a length of 500 mm with equally spaced holes (center to center distance 100mm) with the first hole at 50 mm. The profiles are anchored with a total of 5 concrete screws (Fischer model FBS 10 x 100/15 US A4 as in ETA-11/0095).

The system “DEFENDER DF1012LM” includes plastic clamps (POM), with moving aluminium wedges via a stainless steel M6 screw, and aluminium finishing profiles with TPE sealing gaskets, (Fig. 4.1a). The installation of the glass in the aluminium profile was done with 4 clamps spacing 125 ± 10 mm (Fig. 4.1b).

The measure of the tempered glass pre-stress was made by the laboratory before the beginning of the tests on both specimens (the one used for static tests and the one used dynamic tests) with Laser GASP Grazing Angle Surface Polarimeter. Measured surface stress was between 86.3 MPa and 99.17MPa (static test) and 86.31MPa and 94.54 MPa (impact test).

The balustrade was installed on a concrete element C20/25 casted according to TR048 – EOTA -2016. The average concrete compressive strength (cubic) equal to 30 MPa.

The code of the static test is S-DF1012LM-12T-12I-4SG (type of test (S)- static – profile code (DF1012LM)- thickness and type of glass (12T-12T) interlayer type (SG)).

Similarly, dynamic tests are identified by the type of test: Hard body (H) or semi-hard body (SH) – profile - thickness and type of glass - interlayer type - number of the impact points (1, 2 or 3) according to the code.



Figure 3.1 Glass label

The Technical Head
Sara Cattaneo

Digitally signed in accordance with current legislation.

Milano headquarter- Material Acceptance and Certification Office
via Celoria, 3 – 20133 Milano – Phone +39 02 2399 4210 Fax +39 02 2399 4211

Lecco headquarter
via Gaetano Previati 1/C – 23900 Lecco – Phone +39 0341/48 8793 Fax +39 0341/48 8771

Official Laboratory (art. 20 Law n. 1086 del 5 November 1971) – NB 1777 Reg. (UE) 305/2011



POLITECNICO
MILANO 1863

LABORATORIO PROVE MATERIALI

4. TEST PROCEDURE

Both static and dynamic tests were performed on specimens installed according to the following procedure:

1. Mark the holes on the concrete slab using the profile as template and check the correct position with a level,
2. drill the slab at an embedment depth of 120 mm in the anchoring points,
3. cleaning of the dust,
4. installation of the profile DEFENDER DF1012LM and of the anchors,
5. tightening of the anchors with a torque of 40 Nm,
6. assembly of the clamps on the glass with the spacing of 125 mm,
7. inserting of the glass and the clamps into the aluminium profile
8. inserting of interface rollers and tightening of the wedge with a torque moment of 3 Nm with the torque wrench BETA 583/6 (SN2014/123169) (NOTE: during the tightening it was possible to place the glass in perfect vertical position because the tightening is performed on both side),
9. inserting of the TPE gaskets in the finishing profiles and snap pose of the profile DEFENDER DF1012LM.

The installation was done according to instructions and with the supervision of the company Logli Massimo. Once the glass was placed the test were performed.

During all tests the temperature and the relative humidity were monitored with Extech Instrument RH520 Temperature and Humidity Recorder.

The Technical Head
Sara Cattaneo

Digitally signed in accordance with current legislation.

Milano headquarter- Material Acceptance and Certification Office
via Celoria, 3 – 20133 Milano – Phone +39 02 2399 4210 Fax +39 02 2399 4211

Lecco headquarter
via Gaetano Previati 1/C – 23900 Lecco – Phone +39 0341/48 8793 Fax +39 0341/48 8771

Official Laboratory (art. 20 Law n. 1086 del 5 November 1971) – NB 1777 Reg. (UE) 305/2011



POLITECNICO
MILANO 1863

LABORATORIO PROVE MATERIALI

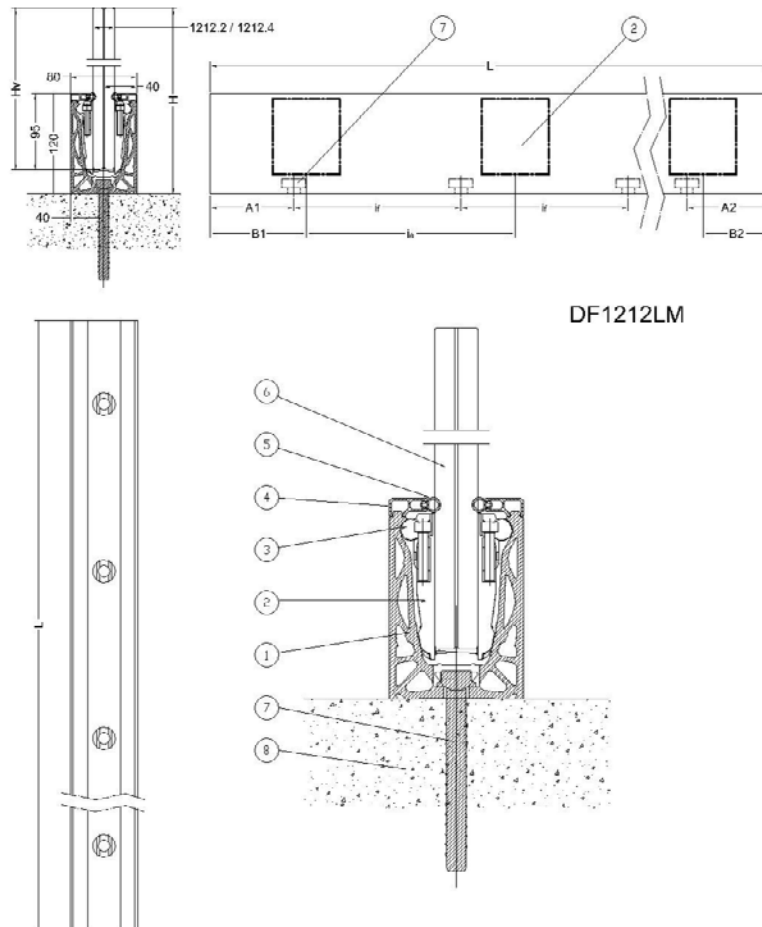

DF1212LM

Installation details			
Ref.	Description	U	Measure
A1	First anchor position	mm	50
A2	Last anchor position	mm	50
i_f	Spacing of the anchors	mm	100
B1	First clamp position	mm	62.5
B2	Last clamp position	mm	62.5
i_a	Spacing of the clamps	mm	125
L	Length of the specimen	mm	500
Hv	Height of the glass ply	mm	1075
H	Height of the balustrade	mm	1100

LEGENDA

- 1) Aluminium structural profile (ref. DF1012LM.60)
- 2) POM clamp with aluminium wedge and adjusting M6 stainless steel screw (ref. DF1212255)
- 3) POM rollers as interface between clamps and structural profile (part of ref. DF1212255)
- 4) Finishing aluminium profile (ref. DF105.60)
- 5) TPE gaskets (ref. DF1010)
- 6) laminated glass ply
- 7) Anchoring (example on concrete)
- 8) base structure

Figura 4.1a System DEFENDER DF1012LM for base mounting of cantilevered balustrade system

The Technical Head
Sara Cattaneo

Digitally signed in accordance with current legislation.

Milano headquarter- Material Acceptance and Certification Office
via Celoria, 3 – 20133 Milano – Phone +39 02 2399 4210 Fax +39 02 2399 4211

Lecco headquarter
via Gaetano Previati 1/C – 23900 Lecco – Phone +39 0341/48 8793 Fax +39 0341/48 8771

Official Laboratory (art. 20 Law n. 1086 del 5 November 1971) – NB 1777 Reg. (UE) 305/2011



POLITECNICO
MILANO 1863

LABORATORIO PROVE MATERIALI

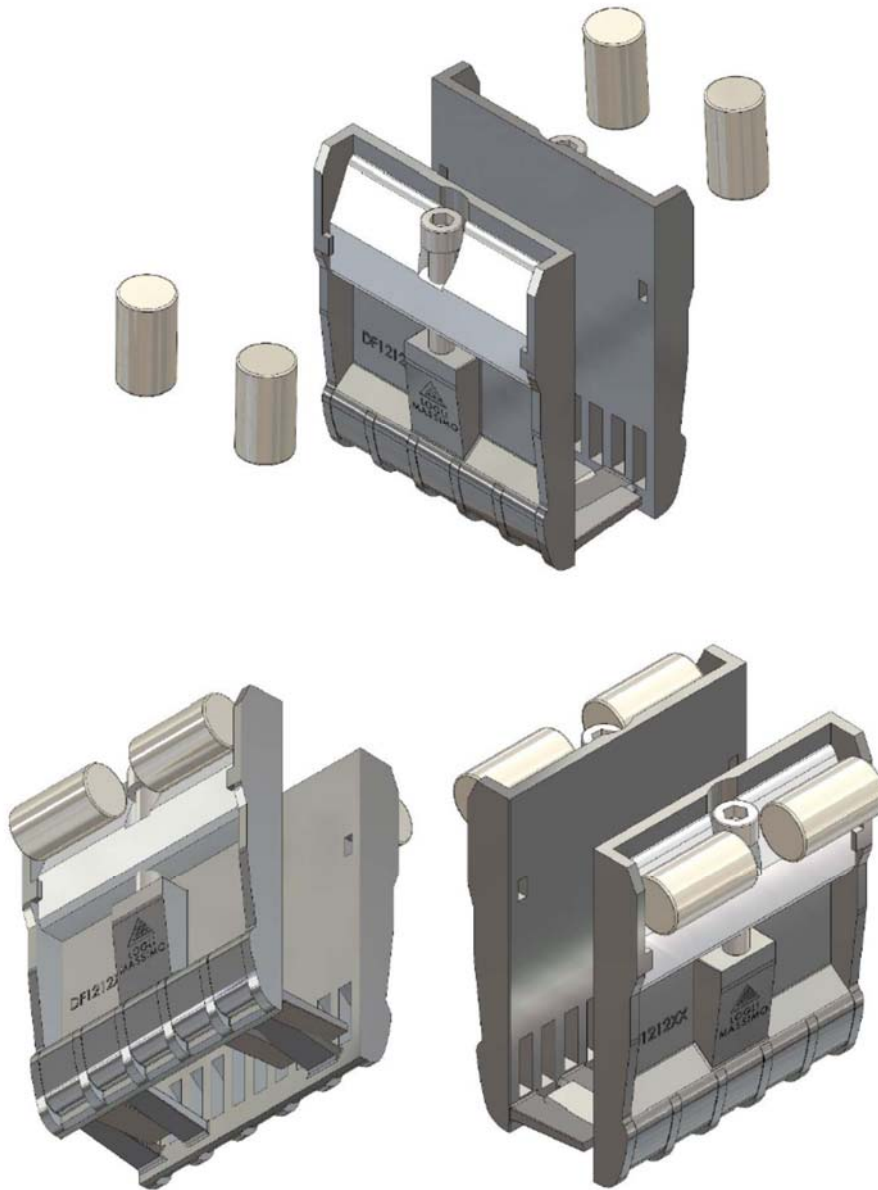

art. DF1212255

Figura 4.1b Clamps for the system DF1012LM ref. DF1212255

The Technical Head
Sara Cattaneo

Digitally signed in accordance with current legislation.

Milano headquarter- Material Acceptance and Certification Office
via Celoria, 3 – 20133 Milano – Phone +39 02 2399 4210 Fax +39 02 2399 4211

Lecco headquarter
via Gaetano Previati 1/C – 23900 Lecco – Phone +39 0341/48 8793 Fax +39 0341/48 8771

Official Laboratory (art. 20 Law n. 1086 del 5 November 1971) – NB 1777 Reg. (UE) 305/2011



POLITECNICO
MILANO 1863

LABORATORIO PROVE MATERIALI

4.1 Static test

The test was performed with a loading system made of a dead load applied in the middle to simulate the load from outside to inside and of four pneumatic jacks attached to the strong floor and that apply the load via four ties attached to the upper edge of the balustrade with spacing 12.5 cm to simulate the load from inside to outside. The sketch of the testing system is shown in Fig. 4.2.

The applied load of each jack was monitored via load cell (AEP TC4 S.N. 430971 -400896 – 715249 – 440041, class 1).

The load measured by the 4 cells was acquired by control system PLC Siemens S7 with specific software designed to maintain a uniform load in the four points.

The displacements were measured with three wire transducers WAYCON SX50-750-1R-KA02, placed at the same height of the load application, at midspan (S.N. 17555215) and with spacing of 12.5 cm (S.N. 18561245 (left), 17555213 (right)) (Fig.4.2).

All data (4 load cells and 3 displacement transducers) were acquired by Spider 8 HBM data acquisition system with specimen frequency of 2 Hz.

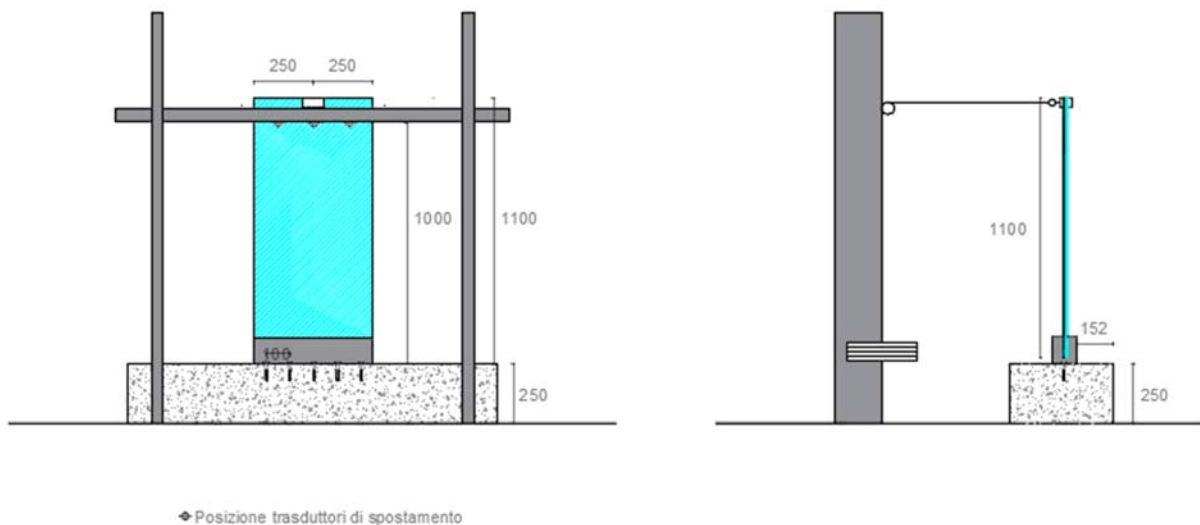

The Technical Head
Sara Cattaneo

Digitally signed in accordance with current legislation.

Milano headquarter- Material Acceptance and Certification Office
via Celoria, 3 – 20133 Milano – Phone +39 02 2399 4210 Fax +39 02 2399 4211

Lecco headquarter
via Gaetano Previati 1/C – 23900 Lecco – Phone +39 0341/48 8793 Fax +39 0341/48 8771

Official Laboratory (art. 20 Law n. 1086 del 5 November 1971) – NB 1777 Reg. (UE) 305/2011



POLITECNICO
MILANO 1863

LABORATORIO PROVE MATERIALI

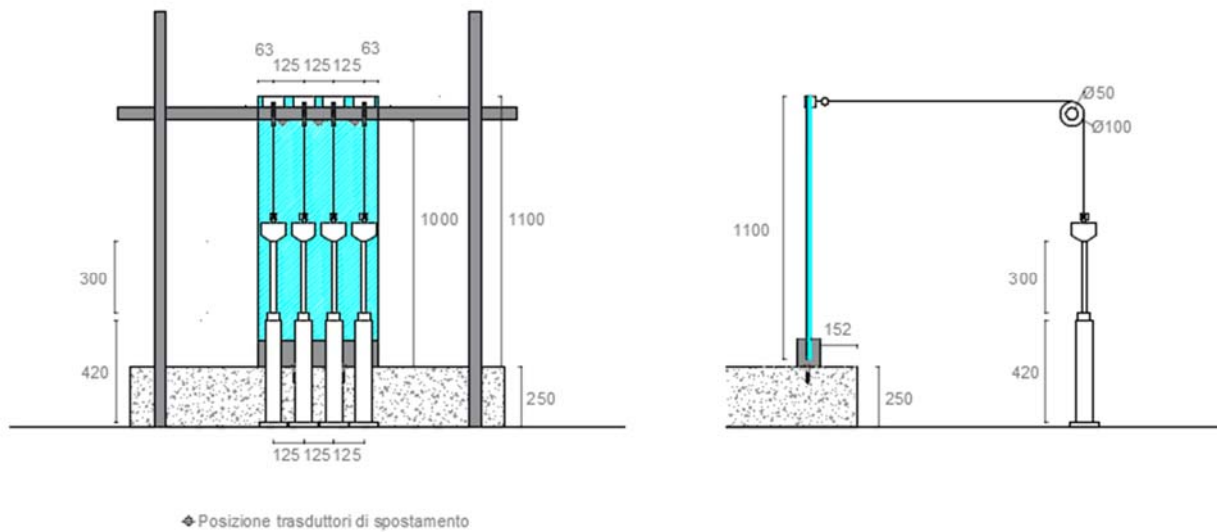

Figure 4.2 – Static test – Sketch of the testing system– Front and lateral view (measure in mm) load from outside to inside (top) from inside to outside (bottom)

The load was applied in the following steps:

From outside to inside:

1. A load of 20 daN (40daN/m) was applied for 180 seconds at the top level in the middle of the balustrade (direction from outside to inside)
2. Unload and reset of the displacement transducers
3. A load of 40 daN (80daN/m) was applied for 180 seconds
4. Unload and check of the residual displacement (lower than 2 mm after 15 minutes)

From inside to outside:

1. A load of 150 daN (300 daN/m) was applied for 180 seconds
2. Unload and reset of the displacement transducers
3. A load of 150 daN (300 daN/m) was applied for 180 seconds, (check the maximum displacement ≤ 35 mm)
4. Unload and check of the residual displacement (lower than 3 mm after 15 minutes)
5. A load of 450 daN (300 daN/m x 3 (safety factor)) was applied for 15 minutes
6. After the load removal the displacements of the unloaded specimen were acquired for 15'

The Technical Head
Sara Cattaneo

Digitally signed in accordance with current legislation.

Milano headquarter- Material Acceptance and Certification Office
via Celoria, 3 – 20133 Milano – Phone +39 02 2399 4210 Fax +39 02 2399 4211

Lecco headquarter
via Gaetano Previati 1/C – 23900 Lecco – Phone +39 0341/48 8793 Fax +39 0341/48 8771

Official Laboratory (art. 20 Law n. 1086 del 5 November 1971) – NB 1777 Reg. (UE) 305/2011



POLITECNICO
MILANO 1863

LABORATORIO PROVE MATERIALI

4.2 Dinamic tests

4.2.1 Hard body impact test

The test was performed using as impactor a tempered steel ball with a diameter of 63.5 mm and weight of 1000 g sustained by an inextensible wire with negligible weight according to the reference code. 3 impact points have been defined according to the sketch shown in Figure 4.3a:

Point 1: along the centerline at a distance of 100 mm from the upper edge of the specimen.

Point 2: along the centerline at half height of the element

Point 3: close to the profile DF1012LM.

The impactor was connected at a fixed point at a distance equal to 180 cm from point 1, 225 cm from point 2 and about 265 cm from point 3. The impactor was placed in contact with the selected point with the wire perpendicular to the floor. Then it is uplifted at the height of 1020 mm with respect to the rest position.

The impactor position was measured with Bosch DLE40 (class II precision ± 1.5 mm).

Each point was hit once.

At the end of the test, the glass was visually inspected to check damages and or anomalies.

4.2.2 Semi-rigid body impact test

The test was performed using as impactor with a mass of 50 kg according to EN12600 standard and to the reference code. The pressure of the two tires was $0,35 \pm 0,02$ MPa.

3 impact points have been defined according to the sketch shown in Figure 4.3b:

Point 1: along the centerline at a distance of 100 mm from the upper edge of the specimen.

Point 2: along the centerline at half height of the element

Point 3: close to the corner at a distance of 250 mm along the bisecting line.

The impactor was connected at a fixed point at a distance equal to 180 cm from point 1, 225 cm from point 2 and about 188 cm from point 3. The impactor was placed in contact with the selected point with the wire perpendicular to the floor. Then it is uplifted at the height of 1200 mm with respect to the rest position.

The impactor position was measured with Bosch DLE40 (class II precision ± 1.5 mm).

Each point was hit once.

At the end of the test, the glass was visually inspected to check damages and or anomalies.

The Technical Head
Sara Cattaneo

Digitally signed in accordance with current legislation.

Milano headquarter- Material Acceptance and Certification Office
via Celoria, 3 – 20133 Milano – Phone +39 02 2399 4210 Fax +39 02 2399 4211

Lecco headquarter
via Gaetano Previati 1/C – 23900 Lecco – Phone +39 0341/48 8793 Fax +39 0341/48 8771

Official Laboratory (art. 20 Law n. 1086 del 5 November 1971) – NB 1777 Reg. (UE) 305/2011

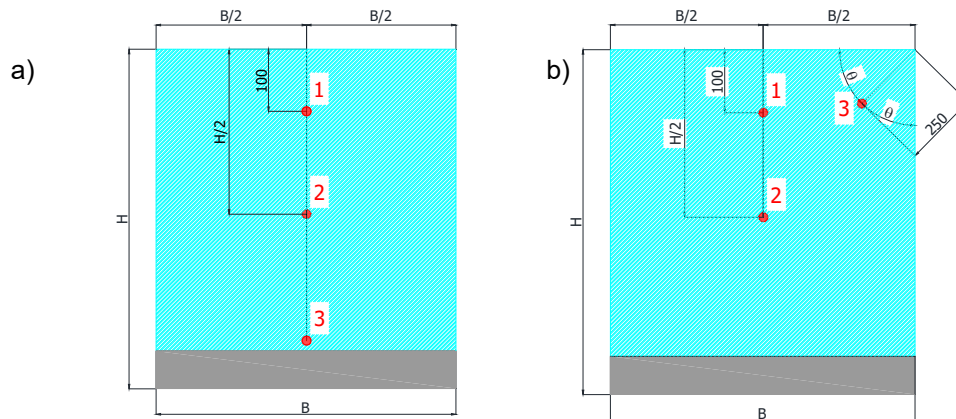

Figure 4.3 – Dynamic tests: Impact points (a) hard body (b) semi-rigid body (measure in mm)

5. TEST RESULTS

5.1 Static test

The average temperature and the relative humidity of the laboratory during the tests were equal to 20°C and 49% respectively.

5.1.1 Specimen S-DF1012LM-12T12T-4SG

Table 5.1 reports the main displacements and requirements at the different stages.

Figure 5.1 shows the load-displacement curves of the pre-load step (Fig.5.1a) and of the serviceability, ultimate and collapse limit state steps (Fig.5.1b). To check the collapse limit state the loaded glass was manually damaged in the upper left corner (Fig.5.2) and the collapse load was applied (C.L.S. equal to 0.6 kN). The measured displacements are shown in Figure 5.1b.

Table 5.1 – Displacements at the main load steps – Specimen S-DF1012LM-12T12T-4SG

STEP	LOAD [daN]	REQUIREMENTS	OBSERVATIONS
SLS INWARDS LOAD	20	-	Displacement under load = 1.52 mm Residual displacement = 0,13 mm OK
SLS INWARDS LOAD	40	Residual displ. < 2 mm (after 15')	Displacement under load = 2.97 mm Residual displacement = 0,13 mm OK

STEP	LOAD [daN/m]	REQUIREMENTS	OBSERVATIONS
SLS OUTWARDS LOAD	300	max. displ. ≤ 35 mm residual displ. ≤ 3 mm (after 15')	Displacement under load = 14.46mm Residual displacement = 0.79mm OK
ULS OUTWARDS LOAD	900	No glass breakage	Displacement under load = 62.27 mm Residual displacement = 10.89mm OK

The Technical Head
Sara Cattaneo

Digitally signed in accordance with current legislation.

Milano headquarter- Material Acceptance and Certification Office
via Celoria, 3 – 20133 Milano – Phone +39 02 2399 4210 Fax +39 02 2399 4211

Lecco headquarter
via Gaetano Previati 1/C – 23900 Lecco – Phone +39 0341/48 8793 Fax +39 0341/48 8771

Official Laboratory (art. 20 Law n. 1086 del 5 November 1971) – NB 1777 Reg. (UE) 305/2011



POLITECNICO
MILANO 1863

LABORATORIO PROVE MATERIALI

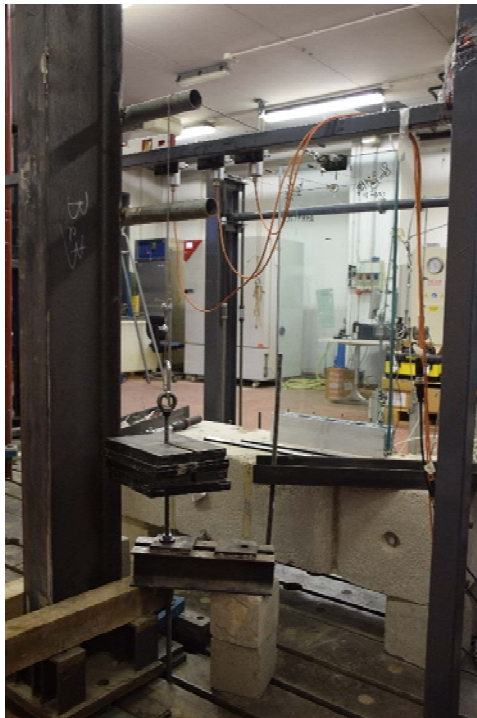

Figure 5.2 – Specimen subjected to load

5.2 Dinamic tests

The average temperature and the relative humidity of the laboratory during the tests were equal to 20.3°C and 51% respectively.

5.2.1 Hard body test – Specimen H- DF1212LM-12T12T-2SG

Points 1-2-3 – The hard body caused local damage as shown in Fig. 5.3

The Technical Head
Sara Cattaneo

Digitally signed in accordance with current legislation.

Milano headquarter- Material Acceptance and Certification Office
via Celoria, 3 – 20133 Milano – Phone +39 02 2399 4210 Fax +39 02 2399 4211

Lecco headquarter
via Gaetano Prevati 1/C – 23900 Lecco – Phone +39 0341/48 8793 Fax +39 0341/48 8771

Official Laboratory (art. 20 Law n. 1086 del 5 November 1971) – NB 1777 Reg. (UE) 305/2011



POLITECNICO
MILANO 1863

LABORATORIO PROVE MATERIALI

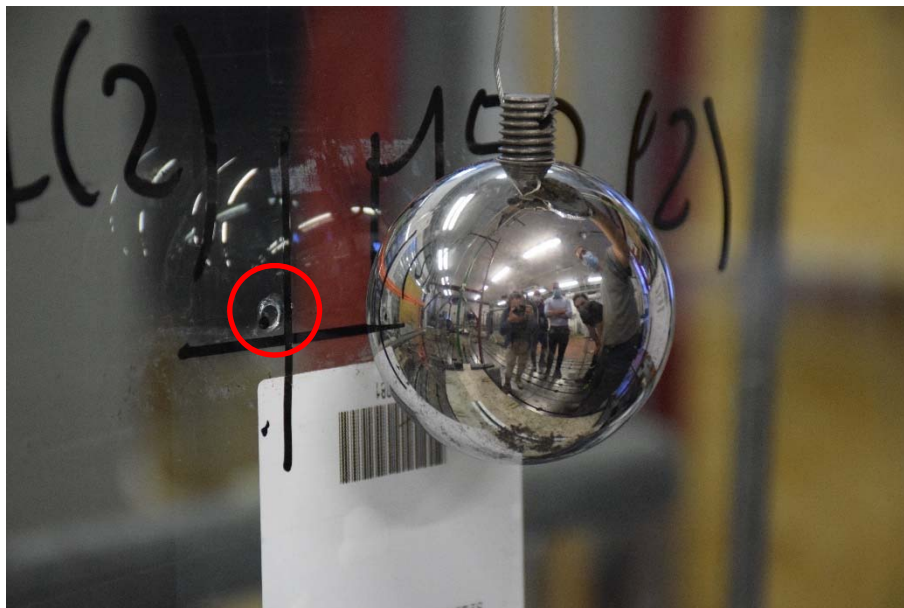
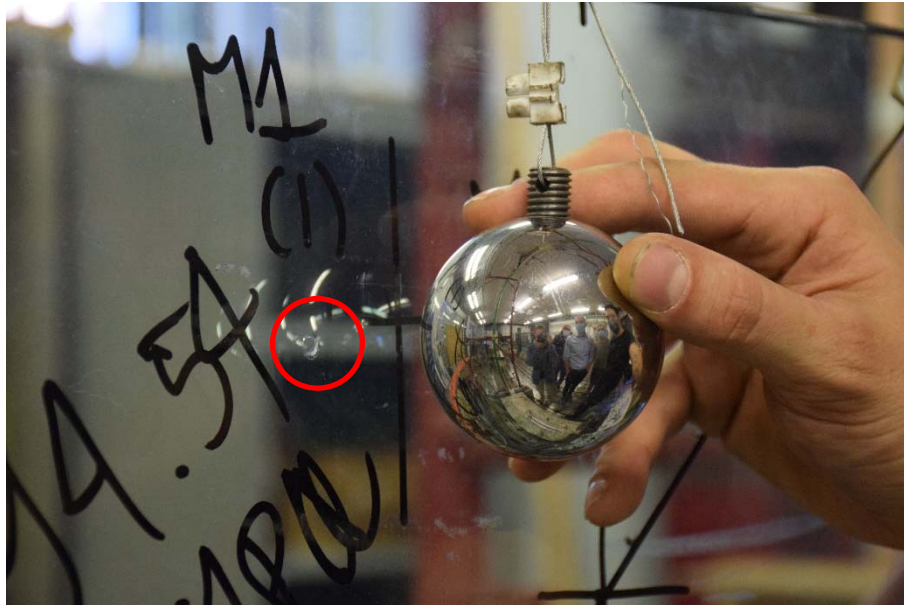

The Technical Head
Sara Cattaneo

Digitally signed in accordance with current legislation.

Milano headquarter- Material Acceptance and Certification Office
via Celoria, 3 – 20133 Milano – Phone +39 02 2399 4210 Fax +39 02 2399 4211

Lecco headquarter
via Gaetano Previati 1/C – 23900 Lecco – Phone +39 0341/48 8793 Fax +39 0341/48 8771

Official Laboratory (art. 20 Law n. 1086 del 5 November 1971) – NB 1777 Reg. (UE) 305/2011



POLITECNICO
MILANO 1863

LABORATORIO PROVE MATERIALI

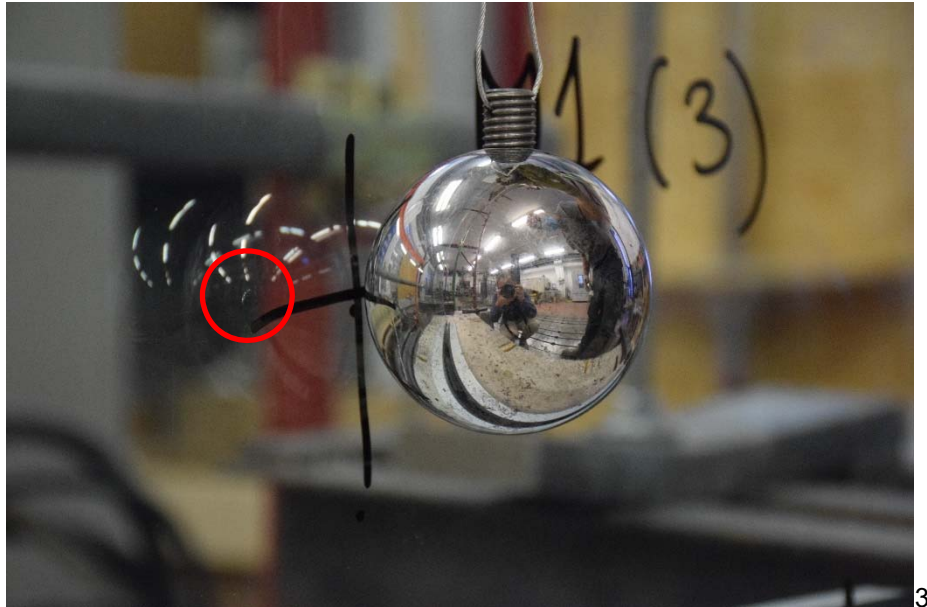

Figure 5.3 – Specimen H-DF1212LM-12T12T-4SG - Point 1, point 2, point 3 – Balustrade during the impact

5.2.2 Semi-rigid impact test – Specimen SH-DF1212LM-12T12T-2SG

Point 1-2-3 – The semi-rigid impactor did not cause any damage as shown in Fig. 5.4.

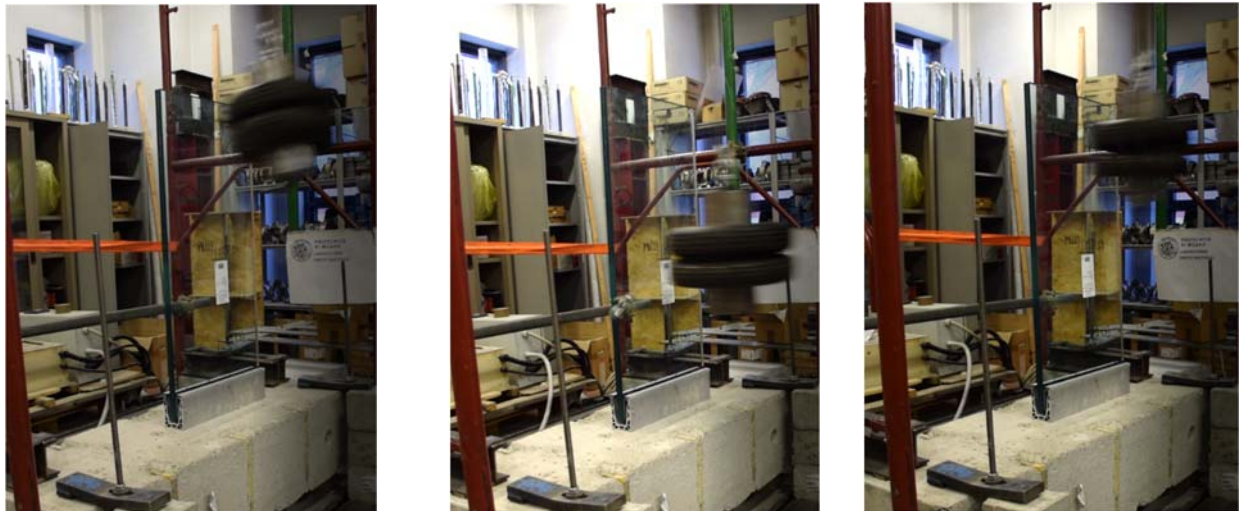

Figure 5.4 – Specimen SH-DF1012LM-12T12T-4SG – Impact points 1-2-3

The Technical Head
Sara Cattaneo

Digitally signed in accordance with current legislation.

Milano headquarter- Material Acceptance and Certification Office
via Celoria, 3 – 20133 Milano – Phone +39 02 2399 4210 Fax +39 02 2399 4211

Lecco headquarter
via Gaetano Previati 1/C – 23900 Lecco – Phone +39 0341/48 8793 Fax +39 0341/48 8771

Official Laboratory (art. 20 Law n. 1086 del 5 November 1971) – NB 1777 Reg. (UE) 305/2011



POLITECNICO
MILANO 1863

LABORATORIO PROVE MATERIALI

6. CONCLUSIONS

The tested specimens assembled with DF1012LM system and laminated glass made with two 12 mm plies (both tempered) with Sentryglas® interlayer (1.52 mm) for a total balustrade height of 1.1 m and a length of 0.5 m satisfied the requirements of:

- UNI 11678:2017 for dynamic loads requirements for building category C5 (rigid impactor test series and semi-rigid impactor with drop height of 1200 mm).
- Cahier du CSTB 3034V3 for static loads requirements in building category C5 (maximum allowed displacements under load, residual displacements at and safety requirements).

According to the requirement of the reference standard §7 it is noted that: *“This report is neither an evaluation of the fitness for use or a compliance certificate of the product. The obtained results are related only to the tested specimens and describe the product behavior under the specific test conditions”.*

The Technical Head
Sara Cattaneo

Digitally signed in accordance with current legislation.

Milano headquarter- Material Acceptance and Certification Office
via Celoria, 3 – 20133 Milano – Phone +39 02 2399 4210 Fax +39 02 2399 4211

Lecco headquarter
via Gaetano Previati 1/C – 23900 Lecco – Phone +39 0341/48 8793 Fax +39 0341/48 8771

Official Laboratory (art. 20 Law n. 1086 del 5 November 1971) – NB 1777 Reg. (UE) 305/2011



POLITECNICO
MILANO 1863

LABORATORIO PROVE MATERIALI

Annex 1

DICHIARAZIONE DI PRESTAZIONE	Riferimento DDT n° 0316 del 30.09.2020
Vetrata stratificata per uso in edilizia e nelle costruzioni	
 CHORUS: 1212.4 SG Chiaro Molato a Filo Lucido Temprato	
Spessore nominale: 25.50 mm	Peso: 62 kg/m ²

CARATTERISTICHE ESSENZIALI	PRESTAZIONE	AVCP system
SICUREZZA IN CASO D'INCENDIO :		
Resistenza al fuoco EN 13501-2	NPD	1
Reazione al fuoco EN 13501-1	NPD	3,4
Resistenza al fuoco proveniente dall'esterno EN 13501-5	NPD	3,4
SICUREZZA NELL'USO :		
Resistenza a sbalzi improvvisi di temperatura e delta di temperatura	NPD	4
Resistenza al carico vento, neve e ai carichi permanenti	NPD	4
Resistenza all'esplosione EN 13541	NPD	1
Resistenza ai proiettili EN 1063	NPD	1
Resistenza agli attacchi manuali EN 356	NPD	3
Resistenza agli urti (prova pendolo) EN 12600	NPD	3
RIDUZIONE E PROTEZIONE DAL RUMORE :		
Isolamento al rumore diretto aereo diretto stimato, comparato a test di composizioni simili effettuati secondo la normativa EN 717 EN 140 o ricavato da UNI 12758		
RW = indice di abbattimento acustico ponderato	NPD	3
C = termine dello spettro del rumore rosa (suoni acuti)	NPD	3
Ctr = termine dello spettro del rumore normalizzato del traffico (suoni bassi)	NPD	3
RISPARMIO ENERGETICO :		
PROPRIETÀ TERMICHE		
Dichiarazione di emissività EN 12898 tolleranza +0.02	0.89	
Valore Ug EN 673 tolleranza +0.1	5.0	3
PROPRIETÀ IRRAGGIAMENTO LUMINOSO secondo EN 410 +/- 3		
Trasmissione luminosa	81	3
Riflessione luminosa	7	3
Fattore solare "g" EN 410	65	3
DURABILITÀ	PASS	3

Si rilascia la presente dichiarazione sotto responsabilità esclusiva del produttore		
 EN 14449:2005 AVCP:3	 QUIDAM <small>VETRO & INNOVAZIONE</small> Strada Ville, 48 - 17014 Cairo Montenotte (SV) Via Cortemilia, 22/24 - 17014 Cairo Montenotte (SV) P.IVA 02672850043	Vetrata Stratificata prodotta secondo UNI EN 14449:2005
LUOGO E DATA DEL RILASCIO	NOME E FUNZIONE	
Cairo Montenotte 30.09.2020	Matteo Ferraiuolo Legale Rappresentante	

The Technical Head
Sara Cattaneo

Digitally signed in accordance with current legislation.

Milano headquarter- Material Acceptance and Certification Office
via Celoria, 3 – 20133 Milano – Phone +39 02 2399 4210 Fax +39 02 2399 4211

Lecco headquarter
via Gaetano Previati 1/C – 23900 Lecco – Phone +39 0341/48 8793 Fax +39 0341/48 8771

Official Laboratory (art. 20 Law n. 1086 del 5 November 1971) – NB 1777 Reg. (UE) 305/2011