

PROGETTO:

Parapetto in vetro DF1010LM / DF1212LM

Contenuto:

01 Definizione resistenze del sistema tramite calcolo statico

REV.:00

DATA:01/04/2020

COMMITTENTE:

SG - Logli Massimo Spa

Via Chemnitz 49/51

I- 59100 Prato

solidic
STRUCTURAL ENGINEERING

Via Nicolodi 39

I-39100 Bolzano (BZ)

T +39 340 379 4992

info@solidic.it

www.solidic.it

VAT: IT 03010420218



Felix Bertagnolli

Tecnico:

Dott-Ing Felix Bertagnolli

Modifiche

REV.	Data	Tecnico	Commenti
00	01/04/2020	BF	Prima edizione

Indice

1	Introduzione	5
1.1	Descrizione	5
1.2	Paese di installazione	7
1.3	Vita nominale	7
1.4	Concetto statico	7
1.5	Stati limiti rispettati	7
1.6	Prova del pendolo	7
1.7	Geometria	8
1.8	Norme	9
1.8.1	Generale	9
1.8.2	Carichi	9
1.8.3	Alluminio	9
1.8.4	Vetro	9
1.9	Software	10
1.10	Coefficienti parziali DIN	10
1.11	Stabilità a lungo termine secondo EN 1990	10
2	Materiali	11
2.1	Alluminio secondo EN 1999-1-1	11
2.2	Vetro secondo DIN 18008	12
2.3	Intercalare	12
2.3.1	PVB	12
2.3.2	SGP (SentryGlas SG5000)	13
3	Carichi	14
3.1	Carico orizzontale di spinta sul colmo	14

3.2	Combinazioni di carico spinta + vento.....	14
4	Calcolo statico.....	15
4.1	Dimensionamento del vetro	15
4.1.1	Informazioni generali.....	15
4.1.2	Dimensionamento vetro - LCA e LCB.....	18
4.1.1	Resistenza del vetro per rottura di un elemento	24
4.2	Dimensionamento del profilo in alluminio	25
4.2.1	Informazioni generali.....	25
4.2.2	Risultati profilo in alluminio LCA_E200	27
4.2.3	Risultati profilo in alluminio LCB_E200	28
4.3	Calcolo del corrimano.....	29
5	Riepilogo risultati vetro e profilo.....	35
5.1	Massima altezza ammissibile del parapetto per solo carico orizzontale hk di spinta sul colmo.....	35
5.2	Massimo carico di vento wk aggiuntivo al carico di spinta orizzontale hk	41
5.3	Reazioni sugli ancoraggi	47
5.4	Massima larghezza lastra in vetro per rottura di un elemento.....	50
5.5	Conclusioni	54
Allegato 57		
	Risultati calcolo del vetro con SJ Mepla	57
	Sistema DF1010LM - vetro temprato 10+10 con 0.76mm PVB	57
	Informazioni generali e risultati calcolo numerico con Sofistik E200-LCA e LCB	61

1 Introduzione

1.1 Descrizione

Sulle seguenti pagine sono riportati i calcoli statici del parapetto in vetro DF1010LM / DF1212LM della ditta Logli. Il parapetto è incastrato alla base per mezzo di un profilo in alluminio, all'interno del quale sarà fissata opportunamente una lastra in vetro stratificato. I bordi del vetro sono protetti. Il bordo superiore della lastra è delimitato dalla presenza di un corrimano che assolve la funzione statica. La costruzione può essere utilizzata come sistema di anticaduta secondo DIN 18008-4 -> gruppo B.

I calcoli statici sono stati eseguiti considerando un'altezza del parapetto L_{tot} variabile partendo da 500 mm fino ad 1320 mm. Le altezze sono considerate a partire dal solaio portante sul quale il profilo è fissato.

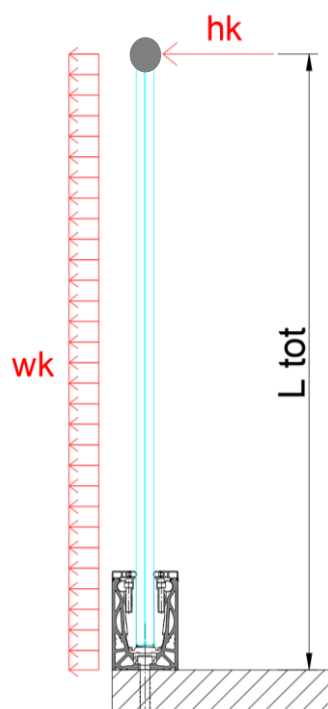

Il profilo estruso è prodotto con la lega EN AW6063-T6 ed è fissato alla base tramite ancoranti posti ad un interasse di 200 mm per un carico lineare h_k fino ad 2.0 kN/m.

I fissaggi dovranno essere verificati per ogni progetto in funzione alle condizioni ambientali. a verifica del sistema del parapetto (vetro+ profilo+ corrimano) è stato eseguito sulla base delle normative vigenti in Germania e sulla base dello stato dell'arte. Le forze applicate al

colmo del parapetto sono di 0.5 kN/m, 1.0 kN/m e 2.0 kN/m secondo la normativa tedesca DIN EN 1991-1-1.

Le stratigrafie del vetro minime ammissibili in funzione ai carichi applicati sono quindi le seguenti:

Interlayer	Glass composition DF1010LM / DF1212LM	
	10+10 FTG	12+12 FTG
PVB 0.76mm	YES	YES
SGP 5000 internal 0.76mm	YES	YES
SGP 5000 external 0.76mm	YES	YES

FTG...fully tempered glass = vetro temprato

Per gli intercalari rigidi due situazioni di installazione diversi sono stati calcolati:

- Installazione all'interno
- Installazione all'esterno

Utilizzando l'intercalare SGP 5000 si considera un trasferimento di taglio come previsto dall'AbZ Nr. Z-70.3-170 mentre per il PVB secondo la DIN 18008-1 nessun trasferimento di taglio può essere considerato.

La valutazione, determinazione e la combinazione dei carichi di spinta orizzontale e vento o eventuali altri carichi deve essere fatta a base della situazione reale di progetto da un tecnico abilitato secondo le normative europee e tedesche attualmente in vigore.

Anche la valutazione dell'installazione del parapetto all'interno o all'esterno (! rigidità differente dell'intercalare), la verifica della massima altezza ammissibile e il dimensionamento dei fissaggi devono essere eseguite da un tecnico abilitato.

Tabelle di predimensionamento per una valutazione approssimativa della scelta del vetro e del profilo si trovano nel capitolo 5.

1.2 Paese di installazione

Germania

1.3 Vita nominale

Vita nominale = 50 anni come per edifici ed altre strutture portanti ordinari

1.4 Concetto statico

Lo schema statico usato per il calcolo del parapetto è di una trave incastrata alla base.

1.5 Stati limiti rispettati

Nel calcolo sono stati rispettati i seguenti stati limiti:

- Stato limite ultimo - carichi statici

1.6 Prova del pendolo

La sicurezza nei confronti della caduta nel vuoto (prova del pendolo) è regolata dal **AbP P-2019-3073** e dal certificato di estensione per i sistemi DF1010LM e DF1212LM del 30.03.2020. Le indicazioni contenute nel 'AbP P-2019-3073, nella estensione e nel report di prova Nr. 2019-3077 del "Labor für Stahl- und Leichtmetallbau GmbH in München" devono essere rispettate.

1.7 Geometria

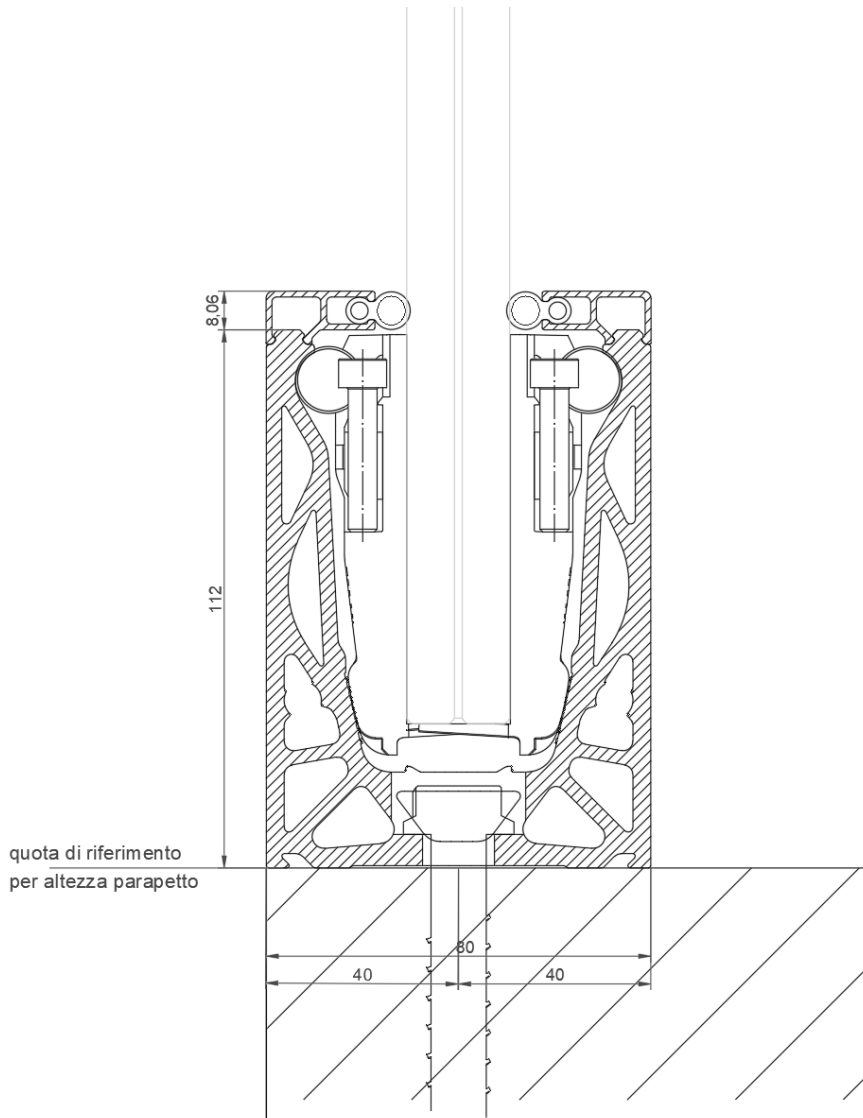

1.8 Norme

1.8.1 Generale

EN 1090 Ausführung von Aluminium- und Stahltragwerken

EN 1090-1	Teil1: Konformitätsnachweisverfahren für tragende Bauteile	03.2012
EN 1090-2	Teil2: Technische Anforderungen an Tragwerke aus Stahl	01.2012
EN 1090-3	Teil3: Technische Regeln für die Ausführung von Aluminiumtragwerken	12.2008

1.8.2 Carichi

Eurocode 0: Grundlagen der Tragwerksplanung

DIN EN 1990	Grundlagen der Tragwerksplanung	12.2010
DIN EN 1990/NA	NAD Grundlagen der Tragwerksplanung	08.2012

Eurocode 1: Einwirkungen auf Tragwerke

DIN EN 1991-1-1	Teil 1-1: Allgemeine Einwirkungen - Wichten, Eigengewicht und Nutzlasten im Hochbau	12.2010
DIN EN 1991-1-4	Teil 1-4: Allgemeine Einwirkungen - Windlasten	12.2010
DIN EN 1991-1-4/NA	NAD Teil 1-4: Allgemeine Einwirkungen - Windlasten	12.2010

1.8.3 Alluminio

DIN EN 1999-1-1	Teil 1-1: Allgemeine Bemessungsregeln	03.2014
DIN EN 1999-1-1/NA	NAD Teil 1-1: Allgemeine Bemessungsregeln	05.2017

1.8.4 Vetro

DIN 18008-1	Teil 1: Begriffe und allgemeine Grundlagen	12.2010
DIN 18008-2	Teil 2: Linienförmig gelagerte Verglasungen	12.2010
DIN 18008-2 Berichtigung 1	Teil 2: Linienförmig gelagerte Verglasungen	04.2011
DIN 18008-4	Teil 4: Zusatzanforderungen an absturzsichernde Verglasungen	07.2013

1.9 Software

Sofistik 2020

SJ Mepla 4.0.7

Microsoft Excel

1.10 Coefficienti parziali DIN

I coefficienti parziali devono essere applicati in modo sfavorevole.

Coefficienti parziali:

- Carichi permanenti 1.35/1.00
- Carichi variabili 1.50/0.00

1.11 Stabilità a lungo termine secondo EN 1990

La vita utile e l'utilizzo degli elementi sono da rispettare nella progettazione e nella scelta della protezione anticorrosione.

Ispezione e manutenzione dei singoli elementi devono essere garantite, oppure applicata una protezione della superficie o protezione anticorrosione adatta.

2 Materiali

2.1 Alluminio secondo EN 1999-1-1

Per lega EN AW 6063-T6 e EP (profili estrusi) con $t \leq 25\text{mm}$

Modulo elastico:	$E=70000 \text{ N/mm}^2$
Coefficiente di Poisson	$\nu=0.30$
Coefficiente di dilatazione termica	$\alpha=23 \cdot 10^{-6} \text{ 1/K}$
Densità	$\rho=2700 \text{ kg/m}^3$
Resistenza a snervamento:	$f_{ok}=160 \text{ N/mm}^2$
Resistenza ultima a trazione:	$f_{uk}=195 \text{ N/mm}^2$
Allungamento a rottura:	$A=8\%$
Coefficiente di sicurezza materiale	$\gamma_m=1.10$

Per il calcolo numerico agli elementi finiti del profilo verrà usato un legame bilineare idealmente elastico-plastico senza incrudimento del materiale secondo EN 1999-1-1 E.2.1.1. e figura E.1b.

$$f_p = f_{max} = f_{ok} / \gamma_m = 160 / 1.10 = 145.45 \text{ N/mm}^2$$

$$\varepsilon_p = f_p / E = 145.45 / 70000 = 0.2 \%$$

$E1=0 \text{ N/mm}^2 \rightarrow$ nessun incrudimento

$$\varepsilon_u = 0.30 - 0.22 \cdot 160 / 400 = 0.212$$

$$\varepsilon_{max} = \min(0.5 \cdot \varepsilon_u, A) = \min(10\%, 8\%) = 8\%$$

Le plasticizzazioni massime ammesse sono del $8\% = 80\%$

2.2 Vetrol secondo DIN 18008

Modulo elastico:	$E=70000 \text{ N/mm}^2$
Coefficiente di Poisson	$\nu=0.23$
Coefficiente di dilatazione termica	$\alpha=9 \cdot 10^{-6} \text{ 1/K}$
Densità	$\rho=2500 \text{ kg/m}^3$

Resistenze caratteristiche vetro f_k :

Vetro temprato (FTG...fully tempered glass) secondo EN 12150-1 (2000):	$f_k=120 \text{ N/mm}^2$
Vetro indurito (HST...heat strengthened glass) secondo EN 1863-1 (2011):	$f_k=70 \text{ N/mm}^2$
Vetro float (FL...float glass) secondo EN 572-1 (2012):	$f_k=45 \text{ N/mm}^2$

Resistenza ultima vetro per verifiche di resistenza a tensione f_{Rd} :

Vetro temprato (FTG) secondo DIN 18008-1 e DIN 18008-2	$f_{Rd}=80 \text{ N/mm}^2$
Vetro indurito (HST) secondo DIN 18008-1 e DIN 18008-2	$f_{Rd}=46.66 \text{ N/mm}^2$
Vetro float (FL) secondo DIN 18008-1 e DIN 18008-2	$f_{Rd}=24.0 \text{ N/mm}^2$ *

* per vetro Float con $k_{mod}=0.7$ per durata corta dei carichi come spinta e vento e con una riduzione a 80% della resistenza a flessione caratteristica per i bordi della lastra regolarmente soggetti a tensioni a trazione.

2.3 Intercalare

2.3.1 PVB

Polyvinyl-Butyral-Interlayer (PVB)

Proprietà meccaniche a 23°C:

Carico di rottura	> 20 N/mm ²
Allungamento alla rottura	> 250 %

Queste proprietà devono essere confermate dal produttore dell'intercalare con il certificato di conformità 2.1 secondo EN 10204:1995-08. La normativa DIN 18008 per intercalari di tipo PVB non consente nessun trasferimento di taglio se agita in modo favorevole.

2.3.2 SGP (SentryGlas SG5000)

secondo DIN 18008 ed AbP Nr.Z-70.3-170

Tabelle 3: Kennwerte für Einfachverglasungen

Lastfall		Schubmodul G [N/mm ²]	k_{vSG}^{12}	k_{mod}
Fassadenbereich	Verglasungen ohne absturzsichernde Funktion			
	Lastfall Wind	100	1	0,7
	Verglasungen mit absturzsichernder Funktion			
	Lastfall horizontale Nutzlast infolge von Personen ¹³	4	1	0,7
	Lastfall Holm und Wind	65	1	0,7
Innenbereich	Verglasungen ohne absturzsichernde Funktion			
	Lastfall Wind	100	1	0,7
	Verglasungen mit absturzsichernder Funktion			
	Lastfall Holm	65	1	0,7
	Lastfall Holm und Wind	65	1	0,7
Überkopf-bereich	Lastfall Schnee	60	1	0,4
	Lastfall Wind und Schnee	60	1	0,7
	Lastfall Eigengewicht	0	1,1	0,25

Con il parapetto usato all'esterno (max 50°C e durata massima di 1h) e il caso di carico spinta orizzontale il seguente modulo di taglio per l'intercalare può essere usato: $G=4.0 \text{ N/mm}^2$

Con il parapetto usato all'interno (max 30°C e durata massima di 1h) e il caso di carico spinta orizzontale il seguente modulo di taglio per l'intercalare può essere usato: $G=65 \text{ N/mm}^2$

Il fattore k_{vSG} è di 1.0 per tutti i casi di carico considerati, il fattore k_{mod} no è di interesse per un vetro indurito rispettivamente è di 1.0

Coefficiente di Poisson SGP5000 secondo AbP

$\nu=0.49$

3 Carichi

3.1 Carico orizzontale di spinta sul colmo

Le forze orizzontali applicate al colmo del parapetto sono di 0.5 kN/m, 1.0 kN/m e 2.0 kN/m secondo la normativa tedesca DIN EN 1991-1-1.

I carichi devono essere applicati alla sommità del parapetto sia nella direzione di carico principale (direzione caduta nel vuoto = caso di carico A - LCA) con il valore pieno che nella direzione opposta (direzione contro caduta nel vuoto = caso di carico B- LCB) con la metà del valore però con almeno 0.50 kN/m.

→ LCA: 0.50 kN/m, 1.00 kN/m, 2.00 kN/m

→ LCB: 0.50 kN/m, 1.00 kN/m

3.2 Combinazioni di carico spinta + vento

Il carico lineare agente sul colmo e il vento agente su tutta la superficie del parapetto sono combinati secondo quanto prescritto dalle norme tramite seguenti relazioni:

$$f_{Ed1} = \gamma_Q \cdot f_{hk} + \psi_{0, \text{vento}} \cdot \gamma_Q \cdot f_{wk}$$

$$f_{Ed2} = \gamma_Q \cdot f_{hk} \cdot \psi_{0, \text{spinta}} + \gamma_Q \cdot f_{wk}$$

con $\gamma_Q = 1.50$, $\psi_{0, \text{vento}} = 0.60$, $\psi_{0, \text{spinta}} = 0.70$

4 Calcolo statico

4.1 Dimensionamento del vetro

4.1.1 Informazioni generali

Il calcolo statico del vetro viene eseguito tramite il programma SJ Mepla.

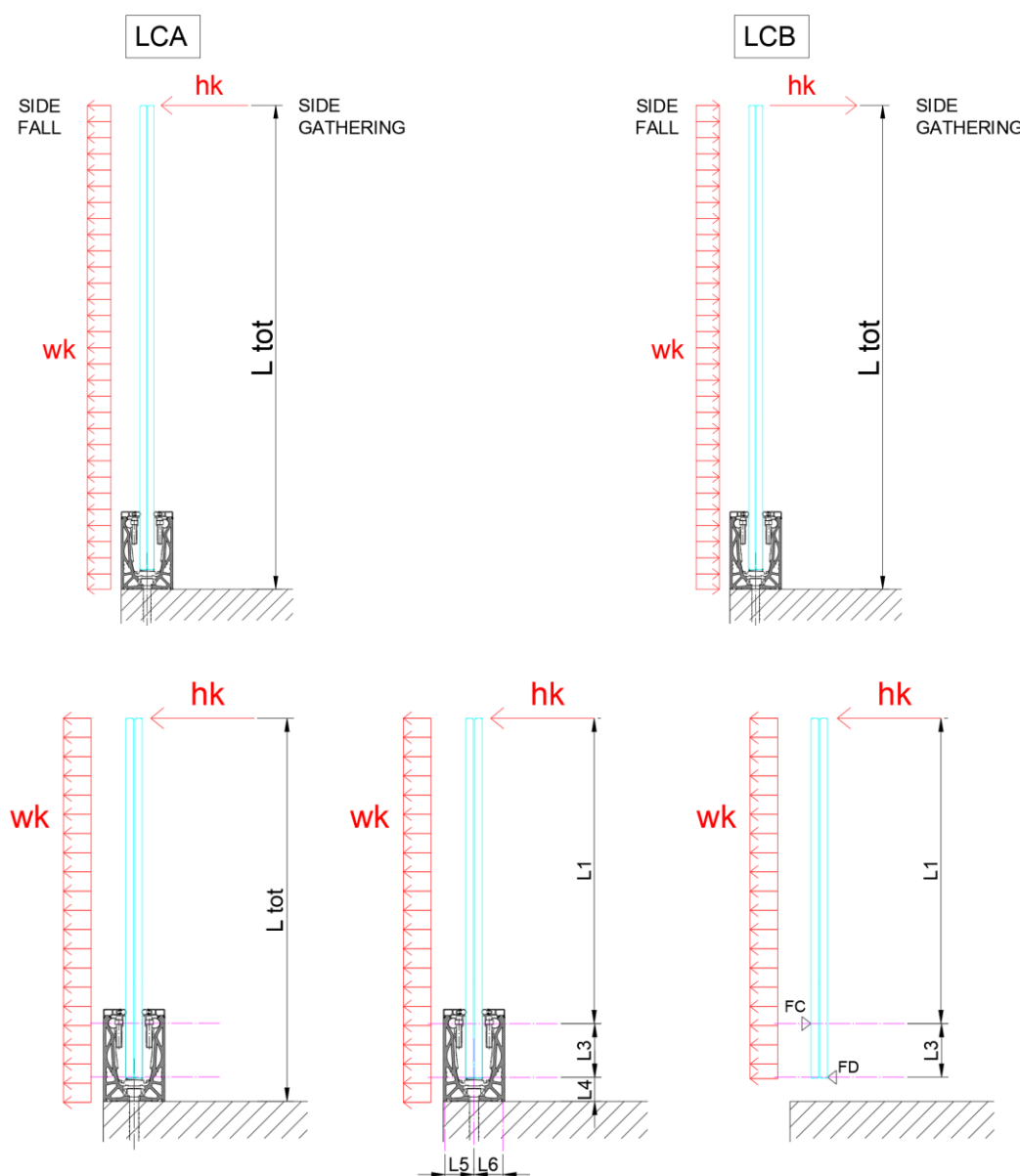

Per il calcolo è stato considerato un incastro rigido all'altezza dell'appoggio superiore del vetro nel profilo di alluminio. L'altezza della lastra rispettivamente la lunghezza libera di flessione L_1 considerata nel calcolo numerico si determina detraendo dall'altezza totale L_{tot} del

parapetto la distanza tra appoggio superiore profilo/vetro fino al solaio su cui il profilo è fissato.

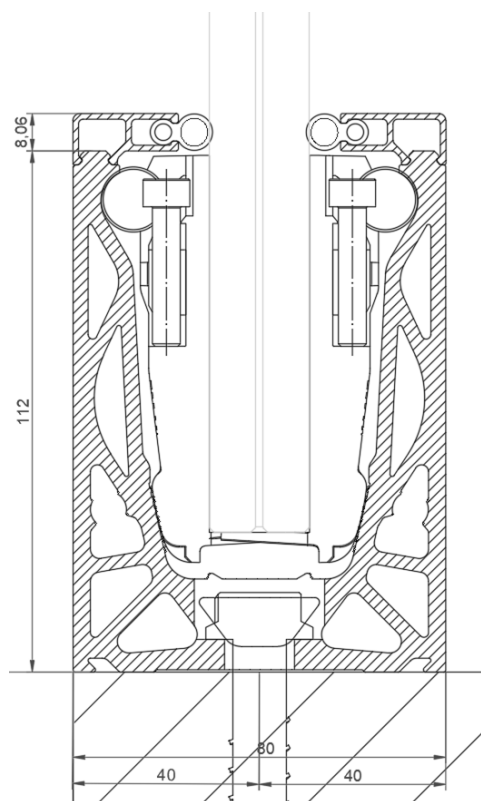

Geometrical distances [mm]						
Profile	L2	L3	L4	L5	L6	e fix 1
DF1010LM DF1212LM	11	70	31	37,6	37,6	200

I seguenti valori di rigidità degli intercalari sono stati usati nei calcoli:

Interlayer	t	G	v	E
-	mm	N/mm ²	-	N/mm ²
PVB	0,76	0.40	0,5	1,2
SGP 5000 internal	0,76	65	0,49	193,7
SGP 5000 external	0,76	4	0,49	11,92

Siccome per alcuni intercalari un trasferimento di taglio è considerato, l'andamento delle tensioni rispettivamente del momento flettente non è costante sull'altezza del vetro.

Il calcolo delle massime tensioni nella lastra di vetro considerando i moduli elastici degli intercalari nelle diverse situazioni di installazione (interno ed esterno) è stato eseguito in due step. Nel primo step è stato applicato un carico unitario lineare di 1.0 kN/m sul colmo del

parapetto in vetro facendo una simulazione per diverse altezze partendo da 500mm fino ad 1320mm in passi di 50mm.

In un secondo step, sapendo la massima tensione ammissibile nel vetro, un eventuale carico di vento uniformemente distribuito su tutta l'altezza e lunghezza della lastra in vetro aggiuntivo al carico di colmo può essere calcolato.

$$f_{d,\text{vetro}} = \gamma_Q \cdot \sigma_{h_k} + \psi_{0,\text{vento}} \cdot \gamma_Q \cdot \sigma_{w_{k1}}$$

$$f_{d,\text{vetro}} = \gamma_Q \cdot \sigma_{h_k} \cdot \psi_{0,\text{spinta}} + \gamma_Q \cdot \sigma_{w_{k2}}$$

$$\sigma_{w_{k1}} = (f_{d,\text{vetro}} - \gamma_Q \cdot \sigma_{h_k}) / (\psi_{0,\text{vento}} \cdot \gamma_Q) \quad \rightarrow \quad w_{k1} = \sigma_{w_{k1}} / \sigma_{\text{max},w_u} \quad \rightarrow \quad w_{k\text{min}} = \min(w_{k1}, w_{k2})$$

$$\sigma_{w_{k2}} = (f_{d,\text{vetro}} - \gamma_Q \cdot \sigma_{h_k} \cdot \psi_{0,\text{spinta}}) / \gamma_Q \quad \rightarrow \quad w_{k2} = \sigma_{w_{k2}} / \sigma_{\text{max},w_u}$$

con $\gamma_Q = 1.50$, $\psi_{0,\text{vento}} = 0.60$, $\psi_{0,\text{spinta}} = 0.70$

Anche le tensioni del vetro dal carico uniformemente distribuito sono state calcolate con una pressione unitaria di 1 kN/m².

Nell'allegato si vede in modo esemplare per un tipo vetro ed intercalare il calcolo Mepla per una certa altezza e carichi unitari $h_u = 1 \text{ kN/m}$ e $w_u = 1 \text{ kN/m}^2$. Per tutte le altre stratigrafie ed altezze il calcolo è stato fatto nello stesso modo modificando soltanto i valori variabili come altezza, intercalare e spessore vetro.

4.1.2 Dimensionamento vetro - LCA e LCB

In seguito, sono riportati i risultati con massima altezza vetro per carico orizzontale e carico di vento aggiuntivo dei vari step di calcolo descritti sopra per le diverse combinazioni intercalare e situazione di installazione.

DF1012LM 10+10mm FTG + 0.76mm PVB

FTG... fully tempered glass

- L3 70 mm distance between top and bottom support of glass into profile
- L4 31 mm distance between bottom support of glass into profile and base ground
- Fu 1 KN/m horizontal unit line load acting on top of parapet
- wu constantly distributed unit load over entire parapet length and height
- E_{int} 1 N/mm² elastic modulus PVB interlayer acc. to DIN 18008-1
- E_{int} 0 N/mm² characteristic resistance FTG acc. to DIN 18008-1
- γ_mFTG 1.20 material safety factor FTG acc. to DIN 18008-1
- γ_mFTG 1.5 design safety factor FTG acc. to DIN 18008-1
- fdFTG 80.00 load combination factor for variable line load
- v/dLL 0.7 load combination factor for variable wind load
- v/dwind 0.6 load safety factor variable loads
- γ_Q 1.5

Lot	L1	hu		w		def		N		σ		k		h		h		h		h	
		mm	mm	mm	mm	mm	mm	mm	mm	mm	mm	mm	mm	mm	mm	mm	mm	mm	mm	mm	mm
401	300	9.17	0.74	1.36	0.08	2.62	0.50	4.59	0.68	0.09	81.25	30.12	59.74	30.86	58.12	30.86	59.74	30.86	58.12	30.86	59.74
451	350	10.73	1.18	1.85	0.15	2.61	0.50	5.37	0.95	0.10	79.95	49.58	43.21	26.80	43.21	26.80	49.58	43.21	26.80	43.21	26.80
501	400	12.30	1.76	2.42	0.26	2.60	0.50	6.15	1.23	0.12	78.64	49.03	43.21	20.26	49.03	20.26	49.03	43.21	20.26	49.03	20.26
551	450	13.88	2.51	3.07	0.42	2.59	0.50	6.94	1.62	0.13	77.32	48.48	43.21	15.79	48.48	15.79	48.48	43.21	15.79	48.48	15.79
601	500	15.49	3.45	3.61	0.64	2.58	0.50	7.75	2.16	0.15	75.98	47.91	43.21	12.58	47.91	12.58	47.91	43.21	12.58	47.91	12.58
651	550	17.11	4.60	4.62	0.94	2.57	0.50	8.56	2.83	0.16	74.63	47.34	43.21	10.25	47.34	10.25	47.34	43.21	10.25	47.34	10.25
701	600	18.75	5.98	5.31	1.34	2.56	0.50	9.38	3.66	0.18	73.26	46.77	43.21	8.49	46.77	8.49	46.77	43.21	8.49	46.77	8.49
751	650	20.39	7.61	6.48	1.84	2.55	0.50	10.20	4.59	0.19	71.90	46.20	43.21	7.13	46.20	7.13	46.20	43.21	7.13	46.20	7.13
801	700	22.05	9.50	7.53	2.46	2.54	0.50	11.03	5.59	0.21	70.51	45.62	43.21	6.06	45.62	6.06	45.62	43.21	6.06	45.62	6.06
851	750	23.70	11.69	9.67	3.27	2.53	0.50	11.85	6.74	0.22	69.14	45.04	43.21	5.19	45.04	5.19	45.04	43.21	5.19	45.04	5.19
901	800	25.37	14.20	11.89	4.23	2.52	0.50	12.69	8.03	0.24	67.75	44.45	43.21	4.49	44.45	4.49	44.45	43.21	4.49	44.45	4.49
951	850	27.04	17.03	14.20	5.40	2.51	0.50	13.52	9.46	0.25	66.36	43.87	43.21	3.92	43.87	3.92	43.87	43.21	3.92	43.87	3.92
1001	900	28.71	20.22	16.57	6.78	2.51	0.50	14.36	10.93	0.27	64.96	43.28	43.21	3.44	43.28	3.44	43.28	43.21	3.44	43.28	3.44
1051	950	30.38	23.79	19.04	8.42	2.50	0.50	15.19	12.44	0.28	63.57	42.70	43.21	3.04	42.70	3.04	42.70	43.21	3.04	42.70	3.04
1101	1000	32.07	27.76	21.76	10.35	2.49	0.50	16.04	14.00	0.30	62.16	42.11	43.21	2.70	42.11	2.70	42.11	43.21	2.70	42.11	2.70
1151	1050	33.75	32.14	24.56	12.58	2.49	0.50	16.88	15.61	0.32	60.76	41.52	43.21	2.41	41.52	2.41	41.52	43.21	2.41	41.52	2.41
1201	1100	35.44	36.96	27.43	15.16	2.48	0.50	17.72	17.28	0.33	59.36	40.93	43.21	2.16	40.93	2.16	40.93	43.21	2.16	40.93	2.16
1251	1150	37.13	42.24	30.27	18.11	2.48	0.50	18.57	19.05	0.35	57.95	40.34	43.21	1.94	40.34	1.94	40.34	43.21	1.94	40.34	1.94
1301	1200	38.82	48.01	33.14	21.46	2.47	0.50	19.41	20.91	0.36	56.54	39.75	43.21	1.75	39.75	1.75	39.75	43.21	1.75	39.75	1.75
1351	1250	40.52	54.28	36.02	25.30	2.47	0.50	20.26	23.89	0.38	55.12	39.15	43.21	1.59	39.15	1.59	39.15	43.21	1.59	39.15	1.59

Lot	L1	hu		w		def		N		σ		k		h		h		h		h	
		mm	mm	mm	mm	mm	mm	mm	mm	mm	mm	mm	mm	mm	mm	mm	mm	mm	mm	mm	mm
401	300	9.17	0.74	1.36	0.08	2.62	0.50	4.59	0.68	0.09	81.25	30.12	59.74	30.86	58.12	30.86	59.74	30.86	58.12	30.86	59.74
451	350	10.73	1.18	1.85	0.15	2.61	0.50	5.37	0.95	0.10	79.95	49.58	43.21	26.80	43.21	26.80	49.58	43.21	26.80	43.21	26.80
501	400	12.30	1.76	2.42	0.26	2.60	0.50	6.15	1.23	0.12	78.64	49.03	43.21	20.26	49.03	20.26	49.03	43.21	20.26	49.03	20.26
551	450	13.88	2.51	3.07	0.42	2.59	0.50	6.94	1.62	0.13	77.32	48.48	43.21	15.79	48.48	15.79	48.48	43.21	15.79	48.48	15.79
601	500	15.49	3.45	3.61	0.64	2.58	0.50	7.75	2.16	0.15	75.98	47.91	43.21	12.58	47.91	12.58	47.91	43.21	12.58	47.91	12.58
651	550	17.11	4.60	4.62	0.94	2.57	0.50	8.56	2.83	0.16	74.63	47.34	43.21	10.25	47.34	10.25	47.34	43.21	10.25	47.34	10.25
701	600	18.75	5.98	5.31	1.34	2.56	0.50	9.38	3.66	0.18	73.26	46.77	43.21	8.49	46.77	8.49	46.77	43.21	8.49	46.77	8.49
751	650	20.39	7.61	6.48	1.84	2.55	0.50	10.20	4.59	0.19	71.90	46.20	43.21	7.13	46.20	7.13	46.20	43.21	7.13	46.20	7.13
801	700	22.05	9.50	7.53	2.46	2.54	0.50	11.03	5.59	0.21	70.51	45.62	43.21	6.06	45.62	6.06	45.62	43.21	6.06	45.62	6.06
851	750	23.70	11.69	9.67	3.27	2.53	0.50	11.85	6.74	0.22	69.14	45.04	43.21	5.19	45.04	5.19	45.04	43.21	5.19	45.04	5.19
901	800	25.37	14.20	11.89	4.23	2.52	0.50	12.69	8.03	0.24	67.75	44.45	43.21	4.49	44.45	4.49	44.45	43.21	4.49	44.45	4.49
951	850	27.04	17.03	14.20	5.40	2.51	0.50	13.52	9.46	0.25	66.36	43.87	43.21	3.92	43.87	3.92	43.87	43.21	3.92	43.87	3.92
1001	900	28.71	20.22	16.57	6.78	2.51	0.50	14.36	10.93	0.27	64.96	43.28	43.21	3.44	43.28	3.44	43.28	43.21	3.44	43.28	3.44
1051	950	30.38	23.79	19.04	8.42	2.50	0.50	15.19	12.44	0.28	63.57	42.70	43.21	3.04	42.70	3.04	42.70	43.21	3.04	42.70	3.04
1101	1000	32.07	27.76	21.76	10.35	2.49	0.50	16.04	14.00	0.30	62.16	42.11	43.21	2.70	42.11	2.70	42.11	43.21	2.70	42.11	2.70
1151	1050	33.75	32.14	24.56	12.58	2.49	0.50	16.88	15.61	0.32	60.76	41.52	43.21	2.41	41.52	2.41	41.52	43.21	2.41	41.52	2.41
1201	1100	35.44	36.96	27.43	15.16	2.48	0.50	17.72	17.28	0.33	59.36	40.93	43.21	2.16	40.93	2.16	40.93	43.21	2.16	40.93	2.16
1251	1150	37.13	42.24	30.27	18.11	2.48	0.50	18.57	19.05	0.35	57.95	40.34	43.21	1.94	40.34	1.94	40.34	43.21	1.94	40.34	1.94
1301	1200	38.82	48.01	33.14	21.46	2.48	0.50	19.41	20.91	0.36	56.54	39.75	43.21	1.75	39.75	1.75	39.75	43.21	1.75	39.75	1.75
1351	1250	40.52	54.28	36.02	25.30	2.47	0.50	20.26	23.89	0.38	55.12	39.15	43.21	1.59	39.15	1.59	39.15	43.21	1.59	39.15	1.59

DF1012LM 10+10mm FTG + 0.76mm SGP-5000 INTERNAL

FTG... fully tempered glass

- L3 70 mm distance between top and bottom support of glass into profile
- L4 31 mm distance between bottom support of glass into profile and base ground
- Fu 1 kN/m horizontal unit line load acting on top of parapet
- wu constantly distributed unit load over entire parapet length and height
- E_{int} 195 N/mm² elastic modulus SGP-5000 INTERNAL acc. to ABP Nr. Z-70.3-170
- f_k FTG 120 N/mm² characteristic resistance FTG acc. to DIN 18008-1
- γ_m FTG 1.5 material safety factor FTG acc. to DIN 18008-1
- f_d FTG 80.00 N/mm² design resistance FTG acc. to DIN 18008-1
- ψ/0 LL 0.7 load combination factor for variable line load
- ψ/0 wind 0.6 load combination factor for variable wind load
- γ_Q 1.5 load safety factor variable loads

		DF1012LM 10+10 FTG + 0.76mm SGP-5000 INTERNAL											
		hk=0.5 kN/m					hk=0.5 kN/m						
lbot	l1	σ _{max.hu}	def.hu	wu	MRd.glas	hk 0.5	σ _{EK,max.0.5}	e _d max.0.5	ut 0.5	σ _{wk1}	wk1	wk2	wkmin.0.5
mm	mm	N/mm ²	mm	N/mm ²	kN/m	kN/m	N/mm ²	N/mm ²	N/mm ²	N/mm ²	kN/m ²	kN/m ²	kN/m ²
1.00	472	7.08	0.09	81.02	108.03	0.50	2.36	3.54	0.04	84.96	113.27	68.91	68.91
1.00	546	8.19	0.10	79.79	79.79	0.50	2.73	4.10	0.05	84.34	84.34	51.42	51.42
1.00	621	9.32	0.12	78.54	60.88	0.50	3.11	4.66	0.06	83.71	64.89	39.66	39.66
1.00	696	10.44	0.13	77.29	48.46	0.50	3.48	5.22	0.07	83.09	50.90	31.42	31.42
1.00	773	11.60	0.14	76.01	47.71	0.50	3.87	5.80	0.07	82.45	41.43	25.44	25.44
1.00	850	12.75	0.16	74.72	47.38	0.50	4.25	6.38	0.08	81.81	34.23	21.07	21.07
1.00	928	13.92	0.17	73.42	46.84	0.50	4.64	6.96	0.09	81.16	28.68	17.70	17.70
1.00	1006	15.09	0.19	72.12	46.29	0.50	5.03	7.55	0.09	80.51	24.32	15.05	15.05
1.00	1084	16.26	0.20	70.82	45.75	0.50	5.42	8.13	0.10	79.86	20.85	12.93	12.93
1.00	1163	17.45	0.22	69.51	45.19	0.50	5.82	8.72	0.11	79.20	18.04	11.22	11.22
1.00	1242	18.63	0.23	68.19	44.64	0.50	6.21	9.32	0.12	78.54	15.74	9.82	9.82
1.00	1321	19.82	0.25	66.87	44.09	0.50	6.61	9.91	0.12	77.88	13.86	8.67	8.67
1.00	1400	21.00	0.26	65.56	43.53	0.50	7.00	10.50	0.13	77.22	12.26	7.69	7.69
1.00	1480	22.20	0.28	64.22	42.97	0.50	7.40	11.10	0.14	76.56	10.91	6.86	6.86
1.00	1560	23.40	0.29	62.89	42.41	0.50	7.80	11.70	0.15	75.89	9.77	6.16	6.16
1.00	1640	24.60	0.31	61.56	41.85	0.50	8.20	12.30	0.15	75.22	8.78	5.55	5.55
1.00	1720	25.80	0.32	60.22	41.29	0.50	8.60	12.90	0.16	74.56	7.92	5.03	5.03
1.00	1800	27.00	0.34	58.89	40.73	0.50	9.00	13.50	0.17	73.89	7.19	4.58	4.58
1.00	1881	28.22	0.35	57.54	40.17	0.50	9.41	14.11	0.18	73.21	6.54	4.17	4.17
1.00	1961	29.42	0.37	56.21	39.61	0.50	9.81	14.71	0.18	72.55	5.97	3.82	3.82

		DF1012LM 10+10 FTG + 0.76mm SGP-5000 INTERNAL											
		hk=1.0 kN/m					hk=2.0 kN/m						
lbot	l1	σ _{EK,max.1.0}	ut 1.0	σ _{wk1}	wk1	wk2	σ _{EK,max.2.0}	e _d max.2.0	ut 2.0	σ _{wk1}	wk1	wk2	wkmin.2.0
mm	mm	N/mm ²	N/mm ²	N/mm ²	kN/m ²	kN/m ²	N/mm ²	N/mm ²	N/mm ²	N/mm ²	kN/m ²	kN/m ²	kN/m ²
1.00	472	7.08	0.09	81.02	108.03	66.71	2.00	9.44	14.16	73.16	97.54	62.30	62.30
1.00	546	8.19	0.10	79.79	79.79	49.51	2.00	10.92	16.38	70.69	45.69	45.69	45.69
1.00	621	9.32	0.12	78.54	60.88	37.97	2.00	12.42	18.63	68.19	44.64	44.64	44.64
1.00	696	10.44	0.13	77.29	48.46	29.91	2.00	13.92	20.88	65.69	43.59	43.59	43.59
1.00	773	11.60	0.14	76.01	47.71	24.08	2.00	15.46	23.19	63.12	42.51	42.51	42.51
1.00	850	12.75	0.16	74.72	47.38	19.83	2.00	17.00	25.50	60.56	41.43	41.43	41.43
1.00	928	13.92	0.17	73.42	46.84	16.55	2.00	18.56	27.84	57.96	40.34	40.34	40.34
1.00	1006	15.09	0.19	72.12	46.29	13.99	2.00	20.12	30.18	55.36	39.25	39.25	39.25
1.00	1084	16.26	0.20	70.82	45.75	11.94	2.00	21.68	32.52	52.76	38.16	38.16	38.16
1.00	1163	17.45	0.22	69.51	45.19	10.29	2.00	23.26	34.89	50.12	37.05	37.05	37.05
1.00	1242	18.63	0.23	68.19	44.64	8.95	2.00	24.84	37.26	47.49	35.95	35.95	35.95
1.00	1321	19.82	0.25	66.87	44.09	7.84	2.00	26.42	39.63	44.86	34.84	34.84	34.84
1.00	1400	21.00	0.26	65.56	43.53	6.91	2.00	28.00	42.00	42.22	33.73	33.73	33.73
1.00	1480	22.20	0.28	64.22	42.97	6.12	2.00	29.60	44.40	40.56	32.61	32.61	32.61
1.00	1560	23.40	0.29	62.89	42.41	5.46	2.00	31.20	46.80	38.99	31.49	31.49	31.49
1.00	1640	24.60	0.31	61.56	41.85	4.88	2.00	32.80	49.20	37.42	30.37	30.37	30.37
1.00	1720	25.80	0.32	60.22	41.29	4.39	2.00	34.40	51.60	35.85	29.25	29.25	29.25
1.00	1800	27.00	0.34	58.89	40.73	3.96	2.00	36.00	54.00	34.28	28.13	28.13	28.13
1.00	1881	28.22	0.35	57.54	40.17	3.59	2.00	37.62	56.43	32.71	27.04	27.04	27.04
1.00	1961	29.42	0.37	56.21	39.61	3.26	2.00	39.22	58.83	31.19	25.88	25.88	25.88

DF1012LM 10+10mm FTG + 0.76mm SGP-5000 EXTERNAL

FTG... fully tempered glass

- L3 70 mm distance between top and bottom support of glass into profile
- L4 31 mm distance between bottom support of glass into profile and base ground
- Fu 1 kN/m horizontal unit line load acting on top of parapet
- wu 1 kN/m² constantly distributed unit load over entire parapet length and height
- E_{int} 12 N/mm² elastic modulus SGP-5000 EXTERNAL acc. to AbP Nr. Z-70.3-170
- f_k FTG 120 N/mm² characteristic resistance FTG acc. to DIN 18008-1
- γ_m FTG 1.5 material safety factor FTG acc. to DIN 18008-1
- f_d FTG 80.00 N/mm² design resistance FTG acc. to DIN 18008-1
- γ₀ LL 0.7 load combination factor for variable line load
- γ₀ wind 0.6 load combination factor for variable wind load
- γ_Q 1.5 load safety factor variable loads

		DF1012LM 10+10 FTG + 0.76mm SGP-5000 EXTERNAL												
Lbot	Ll	hu		wu		MRd.glas		hk=0.5		hk=0.5 kN/m				
		σ _{max} .hu	def.hu	σ _{max} .wu	def.wu	kN/m ²	mm	N/mm ²	mm	N/mm ²	N/mm ²	N/mm ²		
401	300	6.17	0.34	1.00	0.04	3.89	0.50	3.09	4.63	0.06	83.75	51.17	83.75	51.17
451	350	6.91	0.49	1.32	0.07	4.05	0.50	3.46	5.18	0.06	83.13	50.91	62.98	38.57
501	400	7.67	0.67	1.67	0.10	4.17	0.50	3.84	5.75	0.07	82.50	50.65	49.40	30.33
551	450	8.42	0.89	2.07	0.15	4.28	0.50	4.21	6.32	0.08	81.87	50.39	39.55	24.34
601	500	9.18	1.15	2.50	0.22	4.36	0.50	4.59	6.89	0.09	81.24	50.12	32.50	20.05
651	550	9.93	1.46	2.98	0.31	4.43	0.50	4.97	7.45	0.09	80.61	49.86	27.05	16.73
701	600	10.69	1.82	3.49	0.42	4.49	0.50	5.35	8.02	0.10	79.98	49.59	22.92	14.21
751	650	11.44	2.24	4.04	0.56	4.55	0.50	5.72	8.58	0.11	79.36	49.33	19.64	12.21
801	700	12.20	2.72	4.62	0.73	4.59	0.50	6.10	9.15	0.11	78.72	49.06	17.04	10.62
851	750	12.96	3.26	5.25	0.94	4.63	0.50	6.48	9.72	0.12	78.09	48.80	14.87	9.29
901	800	13.72	3.87	5.91	1.19	4.66	0.50	6.86	10.29	0.13	77.46	48.53	13.11	8.21
951	850	14.49	4.56	6.61	1.48	4.69	0.50	7.25	10.87	0.14	76.81	48.26	11.62	7.30
1001	900	15.25	5.33	7.36	1.83	4.72	0.50	7.63	11.44	0.14	76.18	48.00	10.35	6.52
1051	950	16.02	6.18	8.13	2.24	4.74	0.50	8.01	12.02	0.15	75.54	47.73	9.29	5.87
1101	1000	16.79	7.13	8.95	2.72	4.76	0.50	8.40	12.59	0.16	74.90	47.46	8.37	5.30
1151	1050	17.56	8.16	9.81	3.27	4.78	0.50	8.78	13.17	0.16	74.26	47.19	7.57	4.81
1201	1100	18.34	9.30	10.70	3.89	4.80	0.50	9.17	13.76	0.17	73.61	46.91	6.88	4.38
1251	1150	19.11	10.54	11.64	4.61	4.81	0.50	9.56	14.33	0.18	72.96	46.64	6.27	4.01
1301	1200	19.88	11.89	12.61	5.42	4.83	0.50	9.94	14.91	0.19	72.32	46.38	5.74	3.68
1351	1250	20.66	13.35	13.62	6.34	4.84	0.50	10.33	15.50	0.19	71.67	46.10	5.26	3.38

		DF1012LM 10+10 FTG + 0.76mm SGP-5000 EXTERNAL											
hk=1.0	kN/m	hk=1.0		hk=2.0		hk=1.0		hk=2.0		hk=2.0			
		σ _{EK} .max.1.0	ut.1.0	σ _{EK} .max.2.0	ut.2.0	σ _{EK} .max.1.0	wkmin.1.0	σ _{EK} .max.2.0	wkmin.2.0	σ _{EK} .max.1.0	wkmin.1.0		
1.00	6.17	9.36	0.12	78.61	49.01	2.00	13.34	13.51	0.23	68.32	44.70	68.32	44.70
1.00	6.91	10.37	0.13	77.37	36.74	2.00	13.82	20.73	0.26	65.86	43.66	49.89	33.08
1.00	7.67	11.51	0.14	76.11	28.72	2.00	15.34	23.01	0.29	63.32	42.60	37.92	25.51
1.00	8.42	12.63	0.16	74.86	22.92	2.00	16.84	25.26	0.32	60.82	41.55	29.38	20.07
1.00	9.18	13.77	0.17	73.59	18.76	2.00	18.36	27.54	0.34	58.29	40.48	23.32	16.19
1.00	9.93	14.90	0.19	72.34	15.56	2.00	19.86	29.79	0.37	55.79	39.43	18.72	13.23
1.00	10.69	16.04	0.20	71.07	13.14	2.00	21.38	32.07	0.40	53.26	38.37	15.26	10.99
1.00	11.44	17.16	0.21	69.82	11.22	2.00	22.88	34.32	0.43	50.76	37.32	12.56	9.24
1.00	12.20	18.30	0.23	68.56	9.70	2.00	24.40	36.60	0.46	48.22	36.25	10.44	7.85
1.00	12.96	19.44	0.24	67.29	8.43	2.00	25.92	38.88	0.49	45.69	35.19	8.70	6.70
1.00	13.72	20.58	0.26	66.02	7.40	2.00	27.44	41.16	0.51	43.16	34.13	7.30	5.77
1.00	14.49	21.74	0.27	64.74	6.53	2.00	28.98	43.47	0.54	40.59	33.05	6.14	5.00
1.00	15.25	22.88	0.29	63.47	5.80	2.00	30.50	45.75	0.57	38.06	31.98	5.17	4.35
1.00	16.02	24.03	0.30	62.19	5.18	2.00	32.04	48.06	0.60	35.49	30.91	4.37	3.80
1.00	16.79	25.19	0.31	60.91	4.65	2.00	33.58	50.37	0.63	32.92	29.83	3.68	3.33
1.00	17.56	26.34	0.33	59.62	4.18	2.00	35.12	52.68	0.66	30.36	28.75	3.09	2.93
1.00	18.34	27.51	0.34	58.32	3.78	2.00	36.68	55.02	0.69	27.76	27.66	2.59	2.58
1.00	19.11	28.67	0.36	57.04	3.43	2.00	38.22	57.33	0.72	25.19	26.58	2.16	2.16
1.00	19.88	29.82	0.37	55.76	3.13	2.00	39.76	59.64	0.75	22.62	25.50	1.79	1.79
1.00	20.66	30.99	0.39	54.46	2.85	2.00	41.32	61.98	0.77	20.02	24.41	1.47	1.47

DF1012LM 12+12mm FTG + 0.76mm PVB

FTG... fully tempered glass

- L3 70 mm distance between top and bottom support of glass into profile
- L4 31 mm distance between bottom support of glass into profile and base ground
- Fu 1 kN/m horizontal unit line load acting on top of parapet
- wu 1 kN/m² constantly distributed unit load over entire parapet length and height
- E_{int} 0 N/mm² elastic modulus PVB interlayer acc. to DIN 18001
- f_k FTG 120 N/mm² characteristic resistance FTG acc. to DIN 18008-1
- γ_m FTG 1.5 - material safety factor FTG acc. to DIN 18008-1
- f_d FTG 80.00 N/mm² design resistance FTG acc. to DIN 18008-1
- ψ/0 LL 0.7 - load combination factor for variable line load
- ψ/0 wind 0.6 - load combination factor for variable wind load
- γ_Q 1.5 - load safety factor variable loads

Lbot	Ltop	hu			wu			MRdglas			hk=0.5			hk=0.5 kN/m			wk1			wkmin.0.5					
		σmax.hu	def.hu	ut.1.0	σ max.wu	def.wu	ut.0.5	σEK,max.0.5	eEdmax.0.5	ut.0.5	σEK,max.0.5	eEdmax.0.5	ut.0.5	σEK,max.0.5	eEdmax.0.5	ut.0.5	σEK,max.0.5	eEdmax.0.5	ut.0.5	σEK,max.0.5	eEdmax.0.5	ut.0.5	σEK,max.0.5	eEdmax.0.5	ut.0.5
1.00	401	6.37	0.43	0.05	0.94	0.05	3.77	0.50	3.19	4.78	0.06	83.58	51.10	88.92	54.37	54.37	54.37	54.37	54.37	54.37	54.37	54.37	54.37	54.37	54.37
1.00	451	7.45	0.68	0.09	1.28	0.09	3.76	0.50	3.73	5.59	0.07	82.68	50.73	64.59	39.63	39.63	39.63	39.63	39.63	39.63	39.63	39.63	39.63	39.63	39.63
1.00	501	8.54	1.02	0.15	1.68	0.15	3.75	0.50	4.27	6.41	0.08	81.77	50.34	48.67	29.97	29.97	29.97	29.97	29.97	29.97	29.97	29.97	29.97	29.97	29.97
1.00	551	9.64	1.46	0.24	2.14	0.24	3.73	0.50	4.82	7.23	0.09	80.86	49.96	37.78	23.35	23.35	23.35	23.35	23.35	23.35	23.35	23.35	23.35	23.35	23.35
1.00	601	10.76	2.00	0.37	2.64	0.37	3.72	0.50	5.38	8.07	0.10	79.92	49.57	30.27	18.78	18.78	18.78	18.78	18.78	18.78	18.78	18.78	18.78	18.78	18.78
1.00	651	11.88	2.66	0.55	3.21	0.55	3.70	0.50	5.94	8.91	0.11	78.99	49.18	24.61	15.32	15.32	15.32	15.32	15.32	15.32	15.32	15.32	15.32	15.32	15.32
1.00	701	13.02	3.46	0.77	3.83	0.77	3.69	0.50	6.51	9.77	0.12	78.04	48.78	20.38	12.74	12.74	12.74	12.74	12.74	12.74	12.74	12.74	12.74	12.74	12.74
1.00	751	14.16	4.40	1.07	4.50	1.07	3.67	0.50	7.08	10.62	0.13	77.09	48.38	17.13	10.75	10.75	10.75	10.75	10.75	10.75	10.75	10.75	10.75	10.75	10.75
1.00	801	15.31	5.50	1.43	5.23	1.43	3.66	0.50	7.66	11.48	0.14	76.13	47.97	14.56	9.17	9.17	9.17	9.17	9.17	9.17	9.17	9.17	9.17	9.17	9.17
1.00	851	16.46	6.77	1.89	6.02	1.89	3.65	0.50	8.23	12.35	0.15	75.17	47.57	12.49	7.90	7.90	7.90	7.90	7.90	7.90	7.90	7.90	7.90	7.90	7.90
1.00	901	17.62	8.22	2.45	6.87	2.45	3.63	0.50	8.81	13.22	0.17	74.21	47.17	10.80	6.67	6.67	6.67	6.67	6.67	6.67	6.67	6.67	6.67	6.67	6.67
1.00	951	18.78	9.86	3.12	7.77	3.12	3.62	0.50	9.39	14.09	0.18	73.24	46.76	9.43	6.02	6.02	6.02	6.02	6.02	6.02	6.02	6.02	6.02	6.02	6.02
1.00	1001	19.94	11.70	3.93	8.73	3.93	3.61	0.50	9.97	14.96	0.19	72.27	46.35	8.28	5.31	5.31	5.31	5.31	5.31	5.31	5.31	5.31	5.31	5.31	5.31
1.00	1051	21.10	13.77	4.88	9.75	4.88	3.60	0.50	10.55	15.83	0.20	71.31	45.95	7.31	4.71	4.71	4.71	4.71	4.71	4.71	4.71	4.71	4.71	4.71	4.71
1.00	1101	22.27	16.06	5.99	10.83	5.99	3.59	0.50	11.14	16.70	0.21	70.33	45.54	6.49	4.20	4.20	4.20	4.20	4.20	4.20	4.20	4.20	4.20	4.20	4.20
1.00	1151	23.44	18.60	7.28	11.96	7.28	3.58	0.50	11.72	17.58	0.22	69.36	45.13	5.80	3.77	3.77	3.77	3.77	3.77	3.77	3.77	3.77	3.77	3.77	3.77
1.00	1201	24.61	21.39	8.77	13.16	8.77	3.57	0.50	12.31	18.46	0.23	68.38	44.72	5.20	3.40	3.40	3.40	3.40	3.40	3.40	3.40	3.40	3.40	3.40	3.40
1.00	1251	25.79	24.45	10.41	14.41	10.41	3.56	0.50	12.90	19.34	0.24	67.40	44.31	4.68	3.07	3.07	3.07	3.07	3.07	3.07	3.07	3.07	3.07	3.07	3.07
1.00	1301	26.97	27.79	12.43	15.73	12.43	3.56	0.50	13.49	20.23	0.25	66.41	43.89	4.22	2.79	2.79	2.79	2.79	2.79	2.79	2.79	2.79	2.79	2.79	2.79
1.00	1351	28.14	31.42	14.64	17.10	14.64	3.55	0.50	14.07	21.11	0.26	65.44	43.48	3.83	2.54	2.54	2.54	2.54	2.54	2.54	2.54	2.54	2.54	2.54	2.54

hk=1.0	σEK,max.1.0	σEdmax.1.0	hk=1.0 kN/m			hk=2.0 kN/m			wk1	wk2	wkmin.2.0														
			ut.1.0	σEK,max.2.0	eEdmax.2.0	ut.2.0	σEK,max.2.0	eEdmax.2.0																	
1.00	6.37	9.56	0.12	78.27	48.87	83.77	51.99	37.59	2.00	13.74	19.11	0.24	67.66	44.42	71.97	47.25	47.25	47.25	47.25	47.25	47.25	47.25	47.25	47.25	47.25
1.00	7.45	11.18	0.14	76.47	48.12	59.74	37.59	37.59	2.00	14.90	22.35	0.28	64.06	42.90	50.04	35.52	35.52	35.52	35.52	35.52	35.52	35.52	35.52	35.52	35.52
1.00	8.54	12.81	0.16	74.66	47.36	44.44	28.19	28.19	2.00	17.08	25.62	0.32	60.42	41.38	35.97	24.63	24.63	24.63	24.63	24.63	24.63	24.63	24.63	24.63	24.63
1.00	9.64	14.46	0.18	72.82	46.59	34.03	21.77	21.77	2.00	19.28	28.92	0.36	56.76	39.84	28.52	18.62	18.62	18.62	18.62	18.62	18.62	18.62	18.62	18.62	18.62
1.00	10.76	16.14	0.20	70.96	45.80	26.88	17.35	17.35	2.00	21.52	32.28	0.40	53.02	38.27	20.08	14.50	14.50	14.50	14.50	14.50	14.50	14.50	14.50	14.50	14.50
1.00	11.88	17.82	0.22	69.09	45.02	21.52	14.02	14.02	2.00	23.76	35.64	0.45	49.29	36.70	15.35	11.43	11.43	11.43	11.43	11.43	11.43	11.43	11.43	11.43	11.43
1.00	13.02	19.53	0.24	67.19	44.22	17.54	11.55	11.55	2.00	26.04	39.06	0.49	45.49	35.11	11.88	9.17	9.17	9.17	9.17	9.17	9.17	9.17	9.17	9.17	9.17
1.00	14.16	21.24	0.27	65.29	43.42	14.51	9.65	9.65	2.00	28.32	42.48	0.53	41.69	33.51	9.26	7.45	7.45	7.45	7.45	7.45	7.45	7.45	7.45	7.45	7.45
1.00	15.31	22.97	0.29	63.37	42.62	12.12	8.15	8.15	2.00	30.62	45.93	0.57	37.86	31.90	7.24	6.10	6.10	6.10	6.10	6.10	6.10	6.10	6.10	6.10	6.10
1.00	16.46	24.69	0.31	61.46	41.81	10.21	6.95	6.95	2.00	32.92	49.38	0.62	34.02	30.29	5.65	5.03	5.03	5.03	5.03	5.03	5.03	5.03	5.03	5.03	5.03
1.00	18.78	28.17	0.35	59.52	41.00	8.66	5.97	5.97	2.00	35.24	52.86	0.66	30.16	28.67	4.39	4.17	4.17	4.17	4.17	4.17	4.17	4.17	4.17	4.17	4.17
1.00	19.94	29.91	0.37	57.59	40.19	7.41	5.17	5.17	2.00	37.58	56.34	0.70	26.29	27.04	3.38	3.48	3.48	3.48	3.48	3.48	3.48	3.48	3.48	3.48	3.48
1.00	21.10	31.65	0.40	55.66	39.38	6.38	4.51	4.51	2.00	39.88	59.82	0.75	22.42	25.42	2.57	2.91	2.91	2.91	2.91	2.91	2.91	2.91	2.91	2.91	2.91
1.00	22.27	33.41	0.42	53.72	38.56	5.51	3.96	3.96	2.00	42.20	63.30	0.79	18.56	23.79	1.90	2.44	2.44	2.44	2.44	2.44	2.44	2.44	2.44	2.44	2.44
1.00	23.44	35.16	0.44	49.82	36.93	4.17	3.09	3.09	2.00	44.54	66.81	0.84	14.66	22.16	1.35	2.05	2.05	2.05	2.05	2.05	2.05	2.05	2.05	2.05	2.05
1.00	24.61	36.92	0.46	47.87	36.11	3.64	2.74	2.74	2.00	46.88	70.32	0.88	10.76	20.52	0.90	1.72	1.72	1.72	1.72	1.72	1.72	1.72	1.72	1.72	1.72
1.00	25.79	38.69	0.48	45.91	35.28	3.19	2.45	2.45	2.00	49.22	73.83	0.92	6.86	18.88	0.52	1.43	1.43	1.43	1.43	1.43	1.43	1.43	1.43	1.43	1.43
1.00	26.97	40.46	0.51	43.94	34.45	2.79	2.19	2.19	2.00	51.58	77.37	0.97	2.92	17.23	0.20	1.20	1.20	1.20	1.20	1.20	1.20	1.20	1.20	1.20	1.20
1.00	28.14	42.21	0.53	41.99	33.64	2.46	1.97	1.97	2.00	53.94	80.91	1.01	-1.01	15.58	-0.06	0.99	0.99	0.99	0.99	0.99	0.99	0.99	0.99	0.99	0.99
1.00									2.00	56.28	84.42	1.06	-4.91	13.94	-0.29	0.82	0.82	0.82	0.82	0.82	0.82	0.82	0.82	0.82	0.82

DF1012LM 12+12mm FTG + 0.76mm SGP-5000 INTERNAL

FTG... fully tempered glass

- L3 70 mm distance between top and bottom support of glass into profile
- L4 31 mm distance between bottom support of glass into profile and base ground
- Fu 1 kN/m horizontally distributed unit load acting on top of parapet
- wu 1 kN/m² constant distributed unit load over entire parapet length and height
- E_{int} 195 N/mm² elastic modulus SGP-5000 INTERNAL acc. to ABP Nr. Z-70.3-170
- f_k FTG 120 N/mm² characteristic resistance FTG acc. to DIN 18008-1
- γ_m FTG 1.5 material safety factor FTG acc. to DIN 18008-1
- f_d FTG 80.00 N/mm² design resistance FTG acc. to DIN 18008-1
- ψ/0 LL 0.7 load combination factor for variable line load
- ψ/0 wind 0.6 load combination factor for variable wind load
- γ_Q 1.5 load safety factor variable loads

		DF1012LM 12+12 FTG + 0.76mm SGP-5000 INTERNAL											
		hk=0.5 kN/m					hk=0.5 kN/m						
Lbot	Ll	σ _{max.hu}	def.hu	wu	MRd.glas	hk 0.5	eE _k max.0.5	eE _d max.0.5	ut 0.5	σ _{wk1}	wk1	wk2	wkmin.0.5
mm	mm	N/mm ²	mm	N/mm ²	kN/m ²	kN/m	N/mm ²	N/mm ²	N/mm ²	N/mm ²	kN/m ²	kN/m ²	kN/m ²
401	300	3.35	0.11	0.53	7.16	0.50	1.68	2.51	0.03	86.10	162.45	98.42	98.42
451	350	3.87	0.17	0.71	0.02	0.50	1.94	2.90	0.04	85.66	120.65	73.21	73.21
501	400	4.39	0.25	0.92	0.04	0.50	2.20	3.29	0.04	85.23	51.80	56.30	56.30
551	450	4.93	0.35	1.15	0.06	0.50	2.47	3.70	0.05	84.78	73.72	44.88	44.88
601	500	5.47	0.48	1.41	0.09	0.50	2.74	4.10	0.05	84.33	51.42	36.47	36.47
651	550	6.01	0.63	1.69	0.13	0.50	3.01	4.51	0.06	83.88	30.31	30.31	30.31
701	600	6.56	0.82	2.01	0.18	0.50	3.28	4.92	0.06	83.42	41.50	25.39	25.39
751	650	7.11	1.03	2.35	0.25	0.50	3.56	5.33	0.07	82.96	35.30	21.64	21.64
801	700	7.66	1.29	2.71	0.34	0.50	3.83	5.75	0.07	82.51	30.44	18.69	18.69
851	750	8.21	1.58	3.11	0.44	0.50	4.11	6.16	0.08	82.05	26.38	16.23	16.23
901	800	8.76	1.91	3.53	0.57	0.50	4.38	6.57	0.08	81.59	23.11	14.24	14.24
951	850	9.32	2.29	3.98	0.73	0.50	4.66	6.99	0.09	81.12	20.58	12.58	12.58
1001	900	9.88	2.71	4.46	0.91	0.50	4.94	7.41	0.09	80.66	18.08	11.18	11.18
1051	950	10.44	3.19	4.96	1.13	0.50	5.22	7.83	0.10	80.19	16.17	10.02	10.02
1101	1000	11.00	3.71	5.49	1.39	0.50	5.50	8.25	0.10	79.72	14.52	9.01	9.01
1151	1050	11.56	4.29	6.05	1.69	0.50	5.78	8.67	0.11	79.26	13.10	8.15	8.15
1201	1100	12.13	4.93	6.64	2.03	0.50	6.07	9.10	0.11	78.78	11.86	7.39	7.39
1251	1150	12.69	5.63	7.26	2.42	0.50	6.35	9.52	0.12	78.31	10.79	6.73	6.73
1301	1200	13.26	6.40	7.91	2.87	0.50	6.63	9.95	0.12	77.84	9.84	6.16	6.16
1351	1250	13.82	7.23	8.58	3.38	0.50	6.91	10.37	0.13	77.37	48.50	5.65	5.65

		DF1012LM 12+12 FTG + 0.76mm SGP-5000 INTERNAL													
		hk=1.0 kN/m					hk=2.0 kN/m								
Lbot	Ll	σ _{max.1.0}	ut 1.0	σ _{wk1}	wk1	wk2	wkmin.1.0	Hk=2.0	eE _k max.2.0	eE _d max.2.0	ut 2.0	σ _{wk1}	wk1	wk2	wkmin.2.0
mm	mm	N/mm ²	N/mm ²	N/mm ²	kN/m ²	kN/m ²	kN/m ²	kN/m	N/mm ²	N/mm ²	N/mm ²	N/mm ²	kN/m ²	kN/m ²	kN/m ²
1.00	3.35	5.03	0.06	83.31	50.95	96.20	96.20	2.00	6.70	10.05	0.13	77.72	48.64	146.65	91.78
1.00	3.87	5.81	0.07	82.44	50.62	116.11	71.50	2.00	7.74	11.61	0.15	75.99	47.92	107.03	67.49
1.00	4.39	6.59	0.08	81.57	50.26	86.67	54.63	2.00	8.78	13.17	0.16	74.26	47.19	80.71	51.29
1.00	4.93	7.40	0.09	80.67	49.88	70.15	43.38	2.00	9.86	14.79	0.18	72.46	46.43	63.00	40.38
1.00	5.47	8.21	0.10	79.77	49.50	56.58	35.11	2.00	10.94	16.41	0.21	70.66	45.68	50.11	32.39
1.00	6.01	9.02	0.11	78.87	49.13	46.67	29.07	2.00	12.02	18.03	0.23	68.86	44.92	40.74	26.58
1.00	6.56	9.84	0.12	77.96	48.74	38.78	24.25	2.00	13.12	19.68	0.25	67.02	44.15	33.34	21.96
1.00	7.11	10.67	0.13	77.04	48.36	32.78	20.58	2.00	14.22	21.33	0.27	65.19	43.38	27.74	18.46
1.00	7.66	11.49	0.14	76.12	47.97	28.09	17.70	2.00	15.32	22.98	0.29	63.36	42.61	23.38	15.72
1.00	8.21	12.32	0.15	75.21	47.59	24.18	15.30	2.00	16.42	24.63	0.31	61.52	41.84	19.78	13.45
1.00	8.76	13.14	0.16	74.29	47.20	21.05	13.37	2.00	17.52	26.28	0.33	59.69	41.07	16.63	11.63
1.00	9.32	13.98	0.17	73.36	46.81	18.43	11.76	2.00	18.64	27.96	0.35	57.82	40.29	14.53	10.12
1.00	9.88	14.82	0.19	72.42	46.42	16.24	10.41	2.00	19.76	29.64	0.37	55.96	39.50	12.55	8.86
1.00	10.44	15.66	0.20	71.49	46.03	14.41	9.28	2.00	20.88	31.32	0.39	54.09	38.72	10.91	7.81
1.00	11.00	16.50	0.21	70.56	45.63	12.85	8.31	2.00	22.00	33.00	0.41	52.22	37.93	9.51	6.91
1.00	11.56	17.34	0.22	69.62	45.24	11.51	7.48	2.00	23.12	34.68	0.43	50.36	37.15	8.32	6.14
1.00	12.13	18.20	0.23	68.67	44.84	10.34	6.75	2.00	24.26	36.39	0.45	48.46	36.35	7.30	5.47
1.00	12.69	19.04	0.24	67.74	44.45	9.33	6.12	2.00	25.38	38.07	0.48	46.59	35.57	6.42	4.90
1.00	13.26	19.89	0.25	66.79	44.05	8.44	5.57	2.00	26.52	39.78	0.50	44.69	34.77	5.65	4.40
1.00	13.82	20.73	0.26	65.86	43.66	7.68	5.09	2.00	27.64	41.46	0.52	42.82	33.99	4.99	3.96

DF1012LM 12+12mm FTG + 0.76mm SGP-5000 EXTERNAL

FTG... fully tempered glass

- L3 70 mm distance between top and bottom support of glass into profile
- L4 31 mm distance between bottom support of glass into profile and base ground
- Fu 1 kN/m horizontal unit line load acting on top of parapet
- wu 1 kN/m² constantly distributed unit load over entire parapet length and height
- E_{int} 12 N/mm² elastic modulus SGP-5000 EXTERNAL acc. to AbP Nr. Z-70.3-170
- f_k FTG 120 N/mm² characteristic resistance FTG acc. to DIN 18008-1
- γ_m FTG 1.5 material safety factor FTG acc. to DIN 18008-1
- f_d FTG 80.00 N/mm² design resistance FTG acc. to DIN 18008-1
- ψ/0 LL 0.7 load combination factor for variable line load
- ψ/0 wind 0.6 load combination factor for variable wind load
- γ_Q 1.5 load safety factor variable loads

		DF1012LM 12+12 FTG + 0.76mm SGP-5000 EXTERNAL											
		hk=0.5 kN/m					hk=0.5 kN/m						
lbot	l1	σ _{max} .hu	def.hu	wu	MRd.glas	hk 0.5	eEK.max.0.5	eEdmax.0.5	ut 0.5	σwk1	wk1	wk2	wkmin.0.5
mm	mm	N/mm ²	mm	N/mm ²	kN/m ²	kN/m	N/mm ²	N/mm ²	-	N/mm ²	kN/m ²	kN/m ²	kN/m ²
401	300	4.44	0.21	0.71	0.02	5.41	0.50	2.22	3.33	0.04	85.19	51.78	72.93
451	350	4.96	0.31	0.94	0.04	5.65	0.50	2.48	3.72	0.05	84.76	51.60	79.17
501	400	5.50	0.42	1.19	0.06	5.82	0.50	2.75	4.13	0.05	84.31	51.41	80.85
551	450	6.02	0.55	1.48	0.10	5.98	0.50	3.01	4.52	0.06	83.87	51.23	82.67
601	500	6.56	0.71	1.79	0.14	6.10	0.50	3.28	4.92	0.06	83.42	51.04	84.61
651	550	7.08	0.90	2.12	0.19	6.21	0.50	3.54	5.31	0.07	82.99	50.86	86.70
701	600	7.61	1.12	2.49	0.26	6.31	0.50	3.81	5.71	0.07	82.55	50.67	88.93
751	650	8.14	1.37	2.88	0.34	6.39	0.50	4.07	6.11	0.08	82.11	50.48	91.30
801	700	8.67	1.66	3.29	0.45	6.46	0.50	4.34	6.50	0.08	81.66	50.30	93.81
851	750	9.21	1.98	3.74	0.57	6.51	0.50	4.61	6.91	0.09	81.21	50.11	96.46
901	800	9.74	2.35	4.21	0.72	6.57	0.50	4.87	7.31	0.09	80.77	49.92	99.25
951	850	10.27	2.76	4.71	0.90	6.62	0.50	5.14	7.70	0.10	80.33	49.74	102.17
1001	900	10.81	3.22	5.23	1.11	6.66	0.50	5.41	8.11	0.10	79.88	49.55	105.23
1051	950	11.35	3.73	5.78	1.36	6.70	0.50	5.68	8.51	0.11	79.43	49.36	108.44
1101	1000	11.89	4.29	6.36	1.64	6.73	0.50	5.95	8.92	0.11	78.98	49.17	111.80
1151	1050	12.43	4.91	6.97	1.97	6.76	0.50	6.22	9.32	0.12	78.53	48.98	115.31
1201	1100	12.97	5.58	7.60	2.34	6.78	0.50	6.49	9.73	0.12	78.08	48.79	118.97
1251	1150	13.51	6.32	8.26	2.77	6.81	0.50	6.76	10.13	0.13	77.63	48.60	122.78
1301	1200	14.05	7.12	8.95	3.25	6.83	0.50	7.03	10.54	0.13	77.18	48.42	126.73
1351	1250	14.59	7.99	9.66	3.80	6.85	0.50	7.30	10.94	0.14	76.73	48.23	130.83

		DF1012LM 12+12 FTG + 0.76mm SGP-5000 EXTERNAL											
		hk=1.0 kN/m					hk=2.0 kN/m						
lbot	l1	σ _{max} .1.0	def.1.0	wk1	wk2	wkmin.1.0	σEK.max.2.0	eEdmax.2.0	ut 2.0	σwk1	wk1	wk2	wkmin.2.0
mm	mm	N/mm ²	mm	kN/m ²	kN/m ²	kN/m ²	N/mm ²	N/mm ²	-	N/mm ²	kN/m ²	kN/m ²	kN/m ²
401	300	6.66	0.08	81.49	50.23	114.77	2.00	8.98	13.32	0.17	74.09	47.12	104.35
451	350	7.44	0.09	80.62	49.86	85.77	2.00	9.92	14.86	0.19	72.36	46.39	104.35
501	400	8.25	0.10	79.72	49.48	66.99	2.00	11.00	16.50	0.21	70.56	45.63	104.35
551	450	9.03	0.11	78.86	49.12	53.28	2.00	12.04	18.06	0.23	68.82	44.91	104.35
601	500	9.84	0.12	77.96	48.74	43.55	2.00	13.12	19.68	0.25	67.02	44.15	104.35
651	550	10.62	0.13	77.09	48.38	36.36	2.00	14.16	21.24	0.27	65.29	43.42	104.35
701	600	11.42	0.14	76.21	48.01	30.60	2.00	15.22	22.83	0.29	63.52	42.68	104.35
751	650	12.21	0.15	75.32	47.64	26.15	2.00	16.28	24.42	0.31	61.76	41.94	104.35
801	700	13.01	0.16	74.44	47.26	22.63	2.00	17.34	26.01	0.33	59.99	41.20	104.35
851	750	13.82	0.17	73.54	46.89	19.66	2.00	18.42	27.63	0.35	58.19	40.44	104.35
901	800	14.61	0.18	72.66	46.52	17.26	2.00	19.48	29.22	0.37	56.42	39.70	104.35
951	850	15.41	0.19	71.77	46.14	15.24	2.00	20.54	30.81	0.39	54.66	38.96	104.35
1001	900	16.22	0.20	70.87	45.77	13.55	2.00	21.62	32.43	0.41	52.86	38.20	104.35
1051	950	17.03	0.21	69.97	45.39	12.11	2.00	22.70	34.05	0.43	51.06	37.44	104.35
1101	1000	17.84	0.22	69.07	45.01	10.86	2.00	23.78	35.67	0.45	49.26	36.69	104.35
1151	1050	18.65	0.23	68.17	44.63	9.78	2.00	24.85	37.29	0.47	47.46	35.93	104.35
1201	1100	19.46	0.24	67.27	44.25	8.85	2.00	25.94	38.91	0.49	45.66	35.18	104.35
1251	1150	20.27	0.25	66.37	43.88	8.04	2.00	27.02	40.53	0.51	43.86	34.42	104.35
1301	1200	21.08	0.26	65.47	43.50	7.32	2.00	28.10	42.15	0.53	42.06	33.66	104.35
1351	1250	21.89	0.27	64.57	43.12	6.68	2.00	29.18	43.77	0.55	40.26	32.91	104.35

4.1.1 Resistenza del vetro per rottura di un elemento

Secondo le DIN 18008 nel dimensionamento di un parapetto deve essere presa in considerazione la condizione eccezionale di rottura di un elemento in vetro.

In queste condizioni il carico lineare orizzontale agente sul corrimano dovrà essere trasmesso alle due lastre in vetro adiacenti intatte con una distribuzione a 45° così come definito nella figura sottostante.

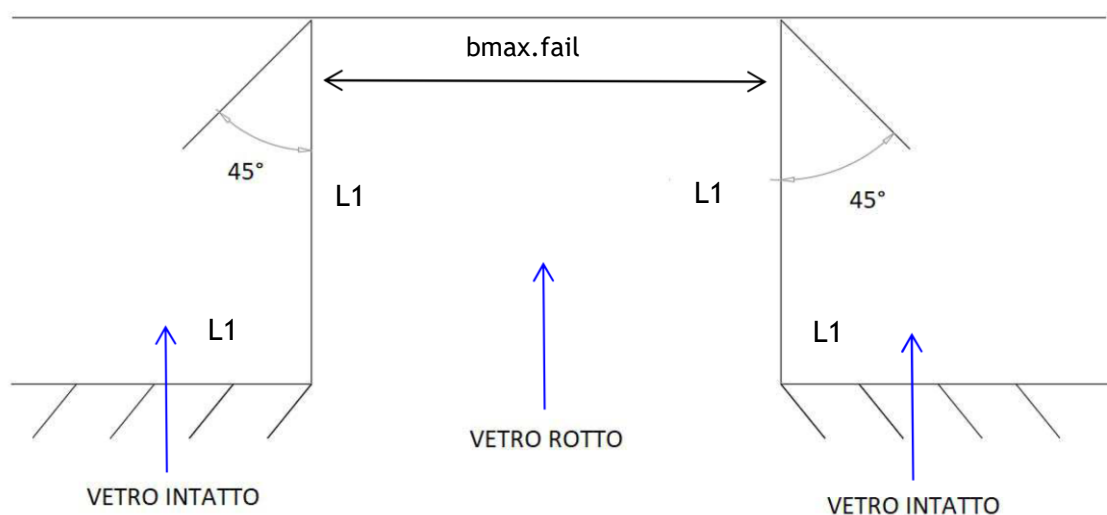

Con $\gamma_Q=1.0$ e $M_{Rd, vetro}$ come resistenza della lastra in vetro nello stato limite ultimo per diverse stratigrafie:

$$MEd, vetro, max = \left(\frac{1.0 * hk * bmax, fail}{2} * L1 \right) = MRd, vetro, L1$$

$$MRd, vetro, L1 = MRd, vetro, lfm * L1$$

$$\rightarrow bmax, fail = \left(\frac{2 * MRd, vetro, lfm}{1.0 * hk} \right)$$

Risultati vedi capitolo 5

4.2 Dimensionamento del profilo in alluminio

4.2.1 Informazioni generali

Il calcolo del profilo in alluminio è condotto tramite il programma di calcolo Sofistik in modo iterativo. In un primo step una certa altezza del sistema parapetto e un carico orizzontale sul colmo è scelto. L'applicazione di tale carico sul vetro genera delle reazioni nel profilo (vedi figure).

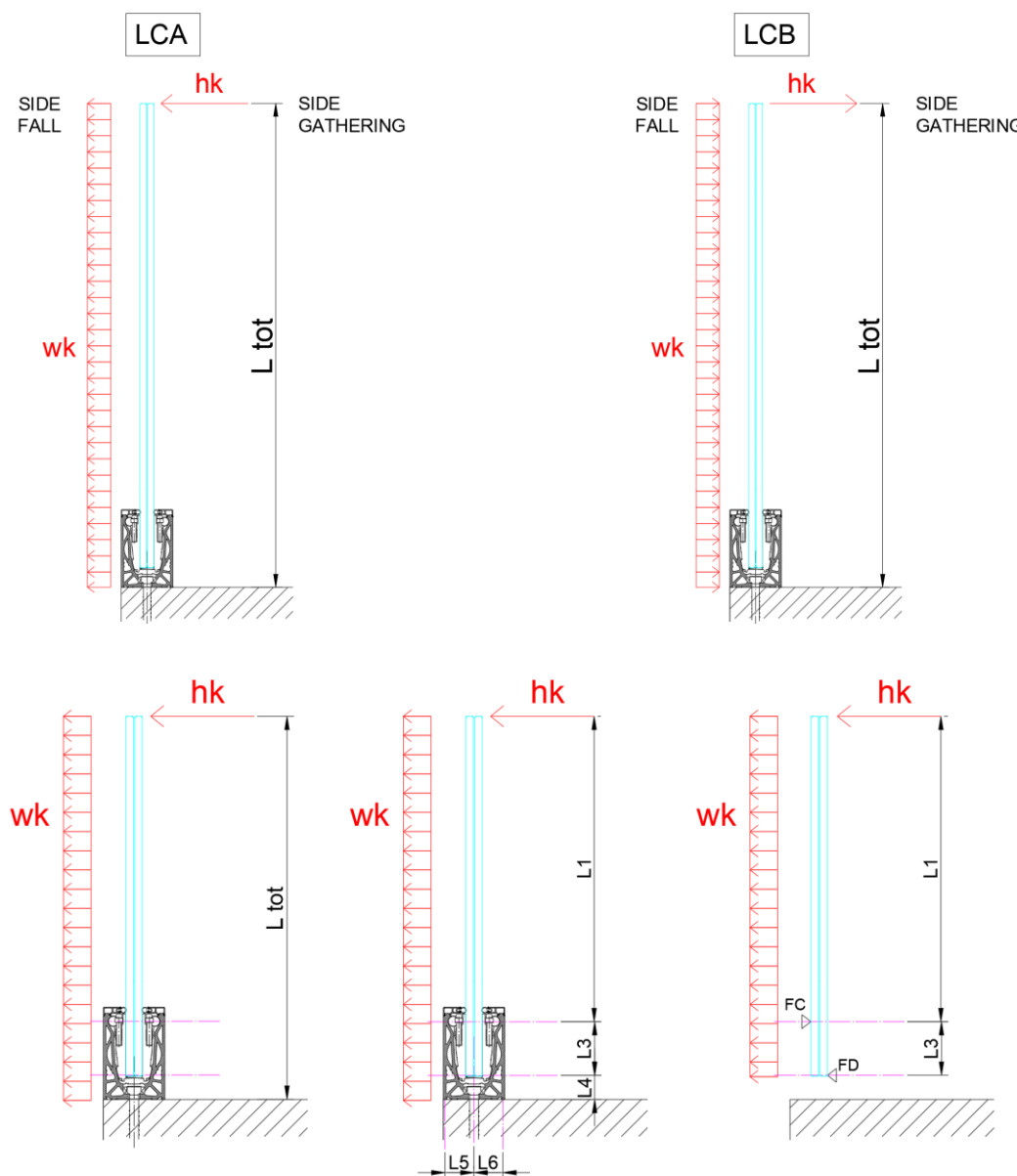

In un secondo step queste due forze di appoggio vetro/profilo verranno applicati come carichi lineari nel calcolo numerico del profilo. Questi carichi poi sono modificati in modo iterativo

finché generano le deformazioni plastiche massime nel profilo di 8% rispettivamente la resistenza ultima è trovata.

Sapendo il massimo carico lineare agente sul profilo corrispondente allo stato limite ultimo il carico aggiuntivo del vento può essere trovato usando le seguenti formule:

$$F_{cd,ult} = F_{cd,h} + F_{cd,wind}$$

Massima reazione agente sul profilo

$$F_{cd,h} = h_d * (L1 + L3) / L3$$

Reazione dovuta al carico orizzontale lineare h_d

$$F_{cd,wind} = W_d * (L1 + L3)^2 / 2 * L3$$

Reazione dovuta al carico distribuito del vento w_d

→ w_d (wk)

vento aggiuntivo al carico lineare orizzontale

4.2.2 Risultati profilo in alluminio LCA_E200

DF1012LM E200 PROFILE - LCA

- L3 70 mm vertical distance between top and bottom support of gable into profile
- L4 31 mm horizontal distance between bottom support of gable into profile and base ground
- L5 27,6 mm horizontal distance between compression and tension reaction at fixation LCA
- L6 27,6 mm horizontal distance between compression and tension reaction at fixation LCB
- e fik 200 mm distance between anchors/roastors
- hu 1 KN/m horizontal unit line load acting on top of parapet
- wu 1 KN/m² constantly distributed unit load over entire parapet length and height
- O 1,5 load safety factor variable loads
- O 0,7 load combination factor for variable line load
- v0 Wind load combination factor for variable wind load
- RdmaxA 13,7/6 KN maximum ultimate top reaction force of gable into profile based on profile resistance

Liot	force gable profile			force gable profile			force gable profile			force gable profile			force gable profile			force gable profile			force gable profile			force gable profile		
	FK.L0	FK.L1	FK.L2	FK.L0	FK.L1	FK.L2	FK.L0	FK.L1	FK.L2	FK.L0	FK.L1	FK.L2	FK.L0	FK.L1	FK.L2	FK.L0	FK.L1	FK.L2	FK.L0	FK.L1	FK.L2	FK.L0	FK.L1	FK.L2
451	300	1,56	-0,38	2,13	2,13	0,20	-0,12	0,43	0,93	0,50	0,60	0,50	0,50	0,50	0,50	0,50	0,50	0,50	0,50	0,50	0,50	0,50	0,50	0,50
500	300	1,20	-1,00	2,40	2,40	0,25	-0,17	0,54	0,94	0,50	0,60	0,50	0,50	0,50	0,50	0,50	0,50	0,50	0,50	0,50	0,50	0,50	0,50	0,50
551	450	1,49	-1,29	2,89	2,89	0,39	-0,28	0,81	1,31	0,50	0,60	0,50	0,50	0,50	0,50	0,50	0,50	0,50	0,50	0,50	0,50	0,50	0,50	0,50
601	600	1,63	-1,43	3,20	3,20	0,46	-0,35	0,96	1,50	0,50	0,60	0,50	0,50	0,50	0,50	0,50	0,50	0,50	0,50	0,50	0,50	0,50	0,50	0,50
701	600	1,97	-1,71	3,73	3,73	0,64	-0,51	1,31	1,31	0,50	0,60	0,50	0,50	0,50	0,50	0,50	0,50	0,50	0,50	0,50	0,50	0,50	0,50	0,50
751	600	2,06	-1,86	3,99	3,99	0,74	-0,60	1,50	1,50	0,50	0,60	0,50	0,50	0,50	0,50	0,50	0,50	0,50	0,50	0,50	0,50	0,50	0,50	0,50
851	750	2,34	-2,14	4,53	4,53	0,96	-0,80	1,93	1,93	0,50	0,60	0,50	0,50	0,50	0,50	0,50	0,50	0,50	0,50	0,50	0,50	0,50	0,50	0,50
901	800	2,49	-2,29	4,79	4,79	1,08	-0,91	2,16	2,16	0,50	0,60	0,50	0,50	0,50	0,50	0,50	0,50	0,50	0,50	0,50	0,50	0,50	0,50	0,50
1001	800	2,77	-2,57	5,32	5,32	1,24	-1,15	2,66	2,66	0,50	0,60	0,50	0,50	0,50	0,50	0,50	0,50	0,50	0,50	0,50	0,50	0,50	0,50	0,50
1051	950	2,91	-2,71	5,59	5,59	1,49	-1,38	2,94	2,94	0,50	0,60	0,50	0,50	0,50	0,50	0,50	0,50	0,50	0,50	0,50	0,50	0,50	0,50	0,50
1201	1100	3,34	-3,14	6,39	6,39	1,79	-1,57	3,52	3,52	0,50	0,60	0,50	0,50	0,50	0,50	0,50	0,50	0,50	0,50	0,50	0,50	0,50	0,50	0,50
1301	1200	3,63	-3,43	6,92	6,92	2,20	-2,05	4,50	4,50	0,50	0,60	0,50	0,50	0,50	0,50	0,50	0,50	0,50	0,50	0,50	0,50	0,50	0,50	0,50
1351	1250	3,77	-3,57	7,19	7,19	2,49	-2,23	4,85	4,85	0,50	0,60	0,50	0,50	0,50	0,50	0,50	0,50	0,50	0,50	0,50	0,50	0,50	0,50	0,50

Liot	force gable profile			force gable profile			force gable profile			force gable profile			force gable profile			force gable profile			force gable profile			force gable profile		
	FK.L0	FK.L1	FK.L2	FK.L0	FK.L1	FK.L2	FK.L0	FK.L1	FK.L2	FK.L0	FK.L1	FK.L2	FK.L0	FK.L1	FK.L2	FK.L0	FK.L1	FK.L2	FK.L0	FK.L1	FK.L2	FK.L0	FK.L1	FK.L2
100	1,00	1,00	-1,00	1,80	1,80	-1,20	2,40	2,40	3,60	3,60	4,20	4,20	4,20	4,20	4,20	4,20	4,20	4,20	4,20	4,20	4,20	4,20	4,20	4,20
100	1,34	1,34	-1,14	2,01	2,01	-1,71	2,66	2,66	4,00	4,00	4,76	4,76	4,76	4,76	4,76	4,76	4,76	4,76	4,76	4,76	4,76	4,76	4,76	4,76
100	1,63	1,63	-1,43	2,44	2,44	-2,14	3,20	3,20	4,80	4,80	5,79	5,79	5,79	5,79	5,79	5,79	5,79	5,79	5,79	5,79	5,79	5,79	5,79	5,79
100	1,77	1,77	-1,57	2,66	2,66	-2,36	3,46	3,46	5,19	5,19	6,39	6,39	6,39	6,39	6,39	6,39	6,39	6,39	6,39	6,39	6,39	6,39	6,39	6,39
100	2,06	2,06	-1,86	3,09	3,09	-2,79	3,99	3,99	5,99	5,99	7,44	7,44	7,44	7,44	7,44	7,44	7,44	7,44	7,44	7,44	7,44	7,44	7,44	7,44
100	2,20	2,20	-2,00	3,30	3,30	-3,00	4,26	4,26	6,39	6,39	8,01	8,01	8,01	8,01	8,01	8,01	8,01	8,01	8,01	8,01	8,01	8,01	8,01	8,01
100	2,63	2,63	-2,43	3,94	3,94	-3,64	5,06	5,06	7,99	7,99	10,01	10,01	10,01	10,01	10,01	10,01	10,01	10,01	10,01	10,01	10,01	10,01	10,01	10,01
100	2,91	2,91	-2,71	4,37	4,37	-4,07	5,59	5,59	8,39	8,39	10,61	10,61	10,61	10,61	10,61	10,61	10,61	10,61	10,61	10,61	10,61	10,61	10,61	10,61
100	3,06	3,06	-2,86	4,59	4,59	-4,29	5,86	5,86	8,78	8,78	11,01	11,01	11,01	11,01	11,01	11,01	11,01	11,01	11,01	11,01	11,01	11,01	11,01	11,01
100	3,49	3,49	-3,29	5,23	5,23	-4,93	6,65	6,65	9,98	9,98	12,49	12,49	12,49	12,49	12,49	12,49	12,49	12,49	12,49	12,49	12,49	12,49	12,49	12,49
100	3,77	3,77	-3,57	5,66	5,66	-5,36	7,19	7,19	10,78	10,78	13,62	13,62	13,62	13,62	13,62	13,62	13,62	13,62	13,62	13,62	13,62	13,62	13,62	13,62

4.3 Calcolo del corrimano





Il calcolo del corrimano viene effettuato sulla base di quanto stabilito nella DIN 18008-4. Nel caso di rottura di un elemento in vetro, il corrimano deve essere progettato in modo da riuscire a distribuire in carichi negli elementi in vetro adiacenti a quello danneggiato. Il dimensionamento si esegue a vantaggio di sicurezza senza rispettare l'esclusiva rottura della lastra sul lato d'impatto. Nella progettazione del singolo progetto può essere rispettata la rigidità della seconda lastra intatta, che porta a lunghezze libere del corrimano più lunghe.

Il corrimano deve essere fissato in modo adeguato alle estremità.

Materiale del corrimano: EN AW 6060-T6

I corrimani corrispondono alle esigenze costruttive della protezione bordo secondo la DIN 18008-4, allegato F.

Si riportano di seguito i vari tipi di corrimano:

AISI316	10+10		CORF50
	10+10		CORLM05 & CORLM07
6060T6	12+12		CORLM53
	10+10		CORLM13 & CORLM15
	12+12		CORLM57

CORF50 (AISI 316=1.4401)

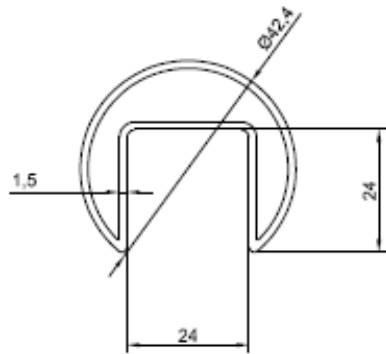

CORLM05 & CORLM07 (EN AW 6060 T6)

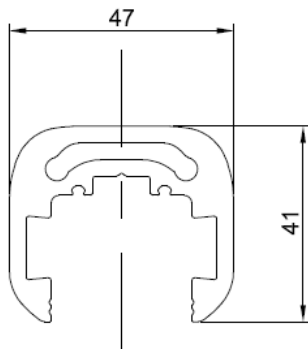

CORLM53 (EN AW 6060 T6)

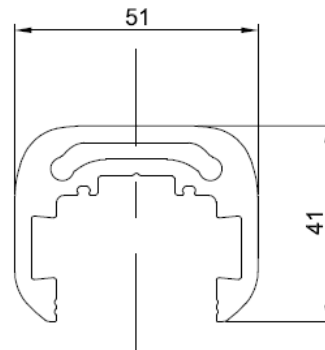

CORLM13 & CORLM15 (EN AW 6060 T6)

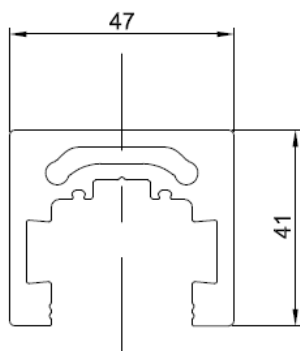

CORLM57 (EN AW 6060 T6)

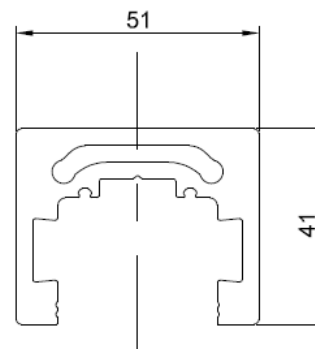

Nelle seguenti tabelle sono riportate le lunghezze massime $L_{max.hr}$ dei diversi tipi di corrimano a base dei carichi applicati per la **situazione accidentale di rottura di una lastra in vetro**.

Perciò il calcolo è stato eseguito assumendo un fattore di sicurezza per i carichi variabili di 1.0. Nell'eventuale caso del calcolo del corrimano nello stato limite ultimo (SLU), i fattori di sicurezza per i carichi variabili devono essere considerati con il valore 1.50.

FOR THE SITUATION OF RUPTURE OF ONE GLAS ELEMENT			CORLM05&CORLM07	CORLM53	CORLM13&CORLM15	CORLM57	CORF50
		Material	EN AW 6060 T6	EN AW 6060 T6	EN AW 6060 T6	EN AW 6060 T6	AISI 316
EN AW 6060 T6	$\gamma_m =$	Glas thickness	10+10	12+12	10+10	12+12	10+10
	1,1	f_{ok} [kN/cm ²]	14	14	14	14	20
AISI 316 (1.4401)	$\gamma_m =$	f_{od} [kN/cm ²]	12,7	12,7	12,7	12,7	18,2
	1,1	MRk [kNcm] from Sofistik	108	124	138	156	47
		MRd [kNcm]	98,2	112,7	125,5	141,8	42,7
hk [kN/m]	0,5	$L_{max.hr}$ [mm]	3963	4247	4480	4763	2615
	1		2803	3003	3168	3368	1849
	2		1982	2123	2240	2382	1307
γ_Q	1						

hr... handrail

La capacità massima del corrimano è definita sulla base della sua resistenza di flessione.

$$MRd.hr = Wel * \frac{f_{ok}}{\gamma_m} = hk * \frac{lhr^2}{8} \rightarrow lhr = \dots$$

Nel capitolo 5 si vedono i risultati in forma grafica.

Nelle seguenti pagine sono riportati i valori di sezione e resistenza caratteristica per i singoli tipi di corrimano calcolati tramite il programma Sofistik.

Solidic - Structural Engineering
SOFSTIK 2020-1.2 AQUA - GENERAL CROSS SECTIONS
Sistema Modulare - Italia, Aluvetto
Querschnitte

Seite 1
2020-03-10

Default design code is Norme Tecniche per le Costruzioni D.M. 17/01/2018 (Italia) V 2020
Structure class: A (Costr. civiltà)
Wind zone : 1 cat. III
Snow load zone : I

Materials

Mat Classification	
1	AW 6060 T6 (EN 1999)

Cross-sections static properties

SNO	Mat	A [mm²]	Ay [mm²]	Iy [mm⁴]	yc [mm]	ysc [mm]	E [N/mm²]	g [kg/m]	I-1 [mm⁴]	I-2 [mm⁴]	α [°]
1	1	6.9987E+02	2.325E+02	9.255E+04	52.6	52.6	70000	1.9	1.910E+05	9.255E+04	0
= CORLM5807											
2	1	7.2787E+02	2.601E+02	9.569E+04	2.6	2.6	70000	2.0	2.366E+05	9.569E+04	90.00
= CORLM3											
3	1	8.1577E+02	2.674E+02	1.278E+05	-34.1	-34.1	70000	2.2	2.429E+05	1.278E+05	0
= CORLM3815											
4	1	8.4377E+02	2.749E+02	1.310E+05	-4.5	-4.5	70000	3.3	2.988E+05	1.310E+05	90.00
= CORLM7											

Mat material number
A [mm²] sectional area
Ay [mm²] Ay [mm²] transverse shear deformation area
Iy [mm⁴] Iy [mm⁴] bending moment of inertia
I [[mm⁴], I-2 [mm⁴], α [°]] principal moments of inertia and angle of the principal axes
E [N/mm²] reinforcement material number
g [kg/m] torsional moment of inertia
I-1 [mm⁴] shear modulus
I-2 [mm⁴]

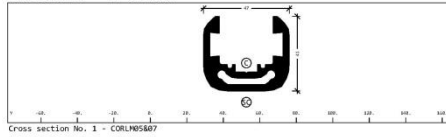

Static properties of cross section

Mat	A [mm²]	Ay [mm²]	Iy [mm⁴]	yc [mm]	ysc [mm]	E [N/mm²]	g [kg/m]	I-1 [mm⁴]	I-2 [mm⁴]	α [°]
1	6.9987E+02	2.325E+02	9.255E+04	52.6	52.6	70000	1.9	1.910E+05	9.255E+04	0
= CORLM5807										

Mat material number
A [mm²] sectional area
Ay [mm²] Ay [mm²] transverse shear deformation area
Iy [mm⁴] Iy [mm⁴] bending moment of inertia

Solidic - Structural Engineering
SOFSTIK 2020-1.2 AQUA - GENERAL CROSS SECTIONS
Sistema Modulare - Italia, Aluvetto
Querschnitte

Seite 2
2020-03-10

e [1/1k]	ymax [mm]	zmax [mm]	hmax [mm]	AB [mm²]	AK [mm³]	Nbs	1/MT [1/m³]	1/Wy [1/m²]	1/Wz [1/m²]
2.4E-05	-25.5	-25.6	57.3	1.291E+02	8.012E+03	7.25E+02	3.419E+05	7.329E+02	7.329E+02
		23.5	55.6						

Additional static properties of cross section

e [1/1k]	ymax [mm]	zmax [mm]	hmax [mm]	AB [mm²]	AK [mm³]	Nbs	1/MT [1/m³]	1/Wy [1/m²]	1/Wz [1/m²]
2.4E-05	-25.5	-25.6	57.3	1.291E+02	8.012E+03	7.25E+02	3.419E+05	7.329E+02	7.329E+02
		23.5	55.6						

Section values for warping

W [mm³]	Wmax [mm³]	CM [cm⁴]	ASyy [mm⁴]	ASzz [mm⁴]	ry [mm]	rz [mm]
-462.1	502.4	3222885	133547	-194	-384	0.0 -58.2

Design values of cross section

Mat	A [mm²]	Ay [mm²]	Iy [mm⁴]	yc [mm]	E [N/mm²]	g [kg/m]	I-1 [mm⁴]	I-2 [mm⁴]	α [°]
1	6.9987E+02	2.325E+02	9.255E+04	52.6	66667	1.9	1.910E+05	9.255E+04	0
= CORLM5807									

Design forces and moments

	N [kN]	Vy [kN]	Vz [kN]	Mx [kNm]	My [kNm]	Mz [kNm]	Hx [kNm]	Hy [kNm]	Hz [kNm]	yc [mm]	zc [mm]	BUCK
C1	98.0	33.03	37.39	0.41	0.71	0.04	0.83	1.58	52.6	5.8	-	0
C2	22.9						0.93	0.08	0.0	2.7		COMP
E	98.0	11.14	10.30	0.10	0.23	0.01	0.51	1.14	52.6	3.7		0
F1	93.3	34.87	35.81	0.40	0.68	0.03	0.85	1.43	52.6	5.8		0
D	21.8						0.85	0.08	0.0	2.7		COMP
F2	93.3	10.61	9.89	0.10	0.22	0.01	0.48	1.08	52.6	2.7		0

Additional design data

Mat	periphery-Q [mm]	defl [mm]	t-min [mm]	t-max [mm]	thet-p [°]	thet-y [°]	thet-z [°]	thet-xy [°]	thet-yz [°]	thet-zx [°]	yg [mm]	zg [mm]
1	246460.5	75359.5	5.7	10.0	0.801	0.000	0.001	0.000	0.000	0.000	52.6	2.7

per periphery-Q:1 periphery area per length
defl deflection depth
t-min t-min thickness
t-max t-max thickness
thet-p thet-p rotation axis
thet-y thet-y rotation axis
thet-z thet-z rotation axis
thet-xy thet-xy rotation axis
thet-yz thet-yz rotation axis
thet-zx thet-zx rotation axis
yg yg coordinate
zg zg coordinate

Solidic - Structural Engineering
SOFSTIK 2020-1.2 AQUA - GENERAL CROSS SECTIONS
Sistema Modulare - Italia, Aluvetto
Querschnitte

Seite 3
2020-03-10

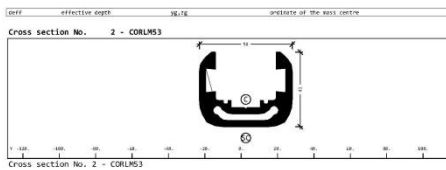

Static properties of cross section

Mat	A [mm²]	Ay [mm²]	Iy [mm⁴]	yc [mm]	ysc [mm]	E [N/mm²]	g [kg/m]	I-1 [mm⁴]	I-2 [mm⁴]	α [°]
1	7.2787E+02	2.601E+02	9.569E+04	2.6	2.6	70000	2.0	2.366E+05	9.569E+04	90.00
= CORLM3										

Mat material number
A [mm²] sectional area
Ay [mm²] Ay [mm²] transverse shear deformation area
Iy [mm⁴] Iy [mm⁴] bending moment of inertia
I [[mm⁴], I-2 [mm⁴], α [°]] principal moments of inertia and angle of the principal axes
E [N/mm²] reinforcement material number
g [kg/m] torsional moment of inertia
I-1 [mm⁴] shear modulus
I-2 [mm⁴]

Solidic - Structural Engineering
SOFSTIK 2020-1.2 AQUA - GENERAL CROSS SECTIONS
Sistema Modulare - Italia, Aluvetto
Querschnitte

Seite 4
2020-03-10

Design forces and moments

	N [kN]	Vy [kN]	Vz [kN]	Mx [kNm]	My [kNm]	Mz [kNm]	Hx [kNm]	Hy [kNm]	Hz [kNm]	yc [mm]	zc [mm]	BUCK
C1	181.9	38.87	37.40	0.44	0.77	0.04	0.92	1.70	2.5	18.1	-	0
C2	24.9						0.86	0.08	0.0	15.0		COMP
E	181.9	13.39	10.83	0.10	0.24	0.01	0.52	1.30	2.6	15.0		0
F1	97.0	37.02	35.62	0.42	0.73	0.04	0.88	1.62	2.5	18.1		0
D	23.7						0.92	0.08	0.0	15.0		COMP
F2	97.0	12.75	10.31	0.10	0.23	0.01	0.49	1.24	2.6	15.0		0

Additional design data

Mat	periphery-Q [mm]	defl [mm]	t-min [mm]	t-max [mm]	thet-p [°]	thet-y [°]	thet-z [°]	thet-xy [°]	thet-yz [°]	thet-zx [°]	yg [mm]	zg [mm]
1	254469.5	83359.5	5.7	10.0	0.801	0.000	0.001	0.000	0.000	0.000	2.6	15.0

per periphery-Q:1 periphery area per length
defl deflection depth
t-min t-min thickness
t-max t-max thickness
thet-p thet-p rotation axis
thet-y thet-y rotation axis
thet-z thet-z rotation axis
thet-xy thet-xy rotation axis
thet-yz thet-yz rotation axis
thet-zx thet-zx rotation axis
yg yg coordinate
zg zg coordinate

Solidic - Structural Engineering
SOFSTIK 2020-1.2 AQUA - GENERAL CROSS SECTIONS
Sistema Modulare - Italia, Aluvetto
Querschnitte

Seite 5
2020-03-10

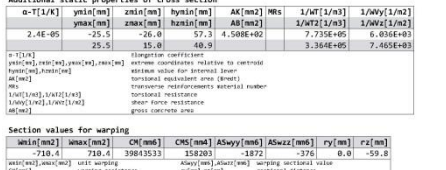

Static properties of cross section

Mat	A [mm²]	Ay [mm²]	Iy [mm⁴]	yc [mm]	ysc [mm]	E [N/mm²]	g [kg/m]	I-1 [mm⁴]	I-2 [mm⁴]	α [°]
1	8.1577E+02	2.674E+02	1.278E+05	-34.1	-34.1	70000	2.2	2.429E+05	1.278E+05	0
= CORLM3815										

Mat material number
A [mm²] sectional area
Ay [mm²] Ay [mm²] transverse shear deformation area
Iy [mm⁴] Iy [mm⁴] bending moment of inertia
I [[mm⁴], I-2 [mm⁴], α [°]] principal moments of inertia and angle of the principal axes
E [N/mm²] reinforcement material number
g [kg/m] torsional moment of inertia
I-1 [mm⁴] shear modulus
I-2 [mm⁴]

Solidic - Structural Engineering
SOFSTIK 2020-1.2 AQUA - GENERAL CROSS SECTIONS
Sistema Modulare - Italia, Aluvetto
Querschnitte

Seite 6
2020-03-10

Design forces and moments

	N [kN]	Vy [kN]	Vz [kN]	Mx [kNm]	My [kNm]	Mz [kNm]	Hx [kNm]	Hy [kNm]	Hz [kNm]	yc [mm]	zc [mm]	BUCK
C1	98.0	33.03	37.39	0.41	0.71	0.04	0.83	1.58	52.6	5.8	-	0
C2	22.9						0.93	0.08	0.0	2.7		COMP
E	98.0	11.14	10.30	0.10	0.23	0.01	0.51	1.14	52.6	3.7		0
F1	93.3	34.87	35.81	0.40	0.68	0.03	0.85	1.43	52.6	5.8		0
D	21.8						0.85	0.08	0.0	2.7		COMP
F2	93.3	10.61	9.89	0.10	0.22	0.01	0.48	1.08	52.6	2.7		0

Additional design data

Mat	periphery-Q [mm]	defl [mm]	t-min [mm]	t-max [mm]	thet-p [°]	thet-y [°]	thet-z [°]	thet-xy [°]	thet-yz [°]	thet-zx [°]	yg [mm]	zg [mm]
1	246460.5	75359.5	5.7	10.0	0.801	0.000	0.001	0.000	0.000	0.000	52.6	2.7

per periphery-Q:1 periphery area per length
defl deflection depth
t-min t-min thickness
t-max t-max thickness
thet-p thet-p rotation axis
thet-y thet-y rotation axis
thet-z thet-z rotation axis
thet-xy thet-xy rotation axis
thet-yz thet-yz rotation axis
thet-zx thet-zx rotation axis
yg yg coordinate
zg zg coordinate

Solidic - Structural Engineering
SOFSTK 2020-12 AQUA - GENERAL CROSS SECTIONS

Sistema Modulare - Italis, Aluvestro
Querschnitte

Additional static properties of cross section

α -T[1/K]	$y_{min}[mm]$	$y_{max}[mm]$	$z_{min}[mm]$	$z_{max}[mm]$	$A[mm^2]$	$I_{yy}[mm^4]$	$I_{zz}[mm^4]$	$I_{yz}[mm^4]$	$I_{yyz}[mm^6]$	$I_{zzz}[mm^6]$
2.4E-05	-25.5	25.5	-45.2	44.2	4.897E+02	6.234E+05	5.845E+03	0	3.189E+05	6.723E+03

Section values for warping

$w_{min}[mm]$	$w_{max}[mm]$	$CW[mm]$	$CS[mm]$	$ASwyy[mm^6]$	$ASwzz[mm^6]$	$ry[mm]$	$rz[mm]$
-68.9	68.9	47639973	18788	-1145	-588	0.0	-57.5

Design values of cross section

Mat	A[mm ²]	Ay[mm ²]	Iy[mm ⁴]	Iy[mm ⁴]	yc[mm]	zc[mm]	E[N/mm ²]	g[kg/m]	I-1[mm ⁴]	I-2[mm ⁴]
1	8.4377E+02	2.745E+02	1.331E+05	1.331E+05	-4.5	-4.5	70000	2.3	2.988E+05	1.310E+05

Design forces and moments

N[kN]	Vy[kN]	Vz[kN]	Mx[kNm]	My[kNm]	Mz[kNm]	Py[kN/m]	Pz[kN/m]	y[mm]	z[mm]	BUCK
C1	114.2	10.81	45.38	0.45	1.01	0.04	1.15	1.84	-34.1	30.7

Additional design data

Mat	periphery-D[mm]	def	r-min[mm]	r-max[mm]	that-p[mm]	that-y[mm]	that-z[mm]	that-yy[mm]	that-yy[mm]	YB	ZB
1	262473.0	0.53550.5	6.1	0.001	0.001	0.000	0.000	0.000	0.000	-34.1	27.1

Solidic - Structural Engineering
SOFSTK 2020-12 AQUA - GENERAL CROSS SECTIONS

Sistema Modulare - Italis, Aluvestro
Querschnitte

Cross section No. 4 - CORLMS7

Static properties of cross section

Mat	A[mm ²]	Ay[mm ²]	Iy[mm ⁴]	Iy[mm ⁴]	yc[mm]	zc[mm]	E[N/mm ²]	g[kg/m]	I-1[mm ⁴]	I-2[mm ⁴]
1	8.4377E+02	2.745E+02	1.331E+05	1.331E+05	-4.5	-4.5	70000	2.3	2.988E+05	1.310E+05

Section values for warping

$w_{min}[mm]$	$w_{max}[mm]$	$CW[mm]$	$CS[mm]$	$ASwyy[mm^6]$	$ASwzz[mm^6]$	$ry[mm]$	$rz[mm]$
-737.0	737.0	57262626	176681	64	-333	0.0	-58.9

Design values of cross section

Mat	A[mm ²]	Ay[mm ²]	Iy[mm ⁴]	Iy[mm ⁴]	yc[mm]	zc[mm]	E[N/mm ²]	g[kg/m]	I-1[mm ⁴]	I-2[mm ⁴]
1	8.4377E+02	2.745E+02	1.331E+05	1.331E+05	-4.5	-4.5	70000	2.3	2.988E+05	1.310E+05

Solidic - Structural Engineering
SOFSTK 2020-12 AQUA - GENERAL CROSS SECTIONS

Sistema Modulare - Italis, Aluvestro
Querschnitte

Additional static properties of cross section

α -T[1/K]	$y_{min}[mm]$	$y_{max}[mm]$	$z_{min}[mm]$	$z_{max}[mm]$	$A[mm^2]$	$I_{yy}[mm^4]$	$I_{zz}[mm^4]$	$I_{yz}[mm^4]$	$I_{yyz}[mm^6]$	$I_{zzz}[mm^6]$
2.4E-05	-25.5	25.5	-45.2	44.2	4.897E+02	6.234E+05	5.845E+03	0	3.189E+05	6.723E+03

Section values for warping

$w_{min}[mm]$	$w_{max}[mm]$	$CW[mm]$	$CS[mm]$	$ASwyy[mm^6]$	$ASwzz[mm^6]$	$ry[mm]$	$rz[mm]$
-68.9	68.9	47639973	18788	-1145	-588	0.0	-57.5

Design values of cross section

Mat	A[mm ²]	Ay[mm ²]	Iy[mm ⁴]	Iy[mm ⁴]	yc[mm]	zc[mm]	E[N/mm ²]	g[kg/m]	I-1[mm ⁴]	I-2[mm ⁴]
1	8.4377E+02	2.745E+02	1.331E+05	1.331E+05	-4.5	-4.5	70000	2.3	2.988E+05	1.310E+05

Design forces and moments

N[kN]	Vy[kN]	Vz[kN]	Mx[kNm]	My[kNm]	Mz[kNm]	Py[kN/m]	Pz[kN/m]	y[mm]	z[mm]	BUCK
C1	114.2	10.81	45.38	0.45	1.01	0.04	1.15	1.84	-34.1	30.7

Additional design data

Mat	periphery-D[mm]	def	r-min[mm]	r-max[mm]	that-p[mm]	that-y[mm]	that-z[mm]	that-yy[mm]	that-yy[mm]	YB	ZB
1	262473.0	0.53550.5	6.1	0.001	0.001	0.000	0.000	0.000	0.000	-34.1	27.1

Solidic - Structural Engineering
SOFSTK 2020-12 AQUA - GENERAL CROSS SECTIONS

Sistema Modulare - Italis, Aluvestro
Querschnitte

Cross section No. 5 - CORFSB

Static properties of cross section

Mat	A[mm ²]	Ay[mm ²]	Iy[mm ⁴]	Iy[mm ⁴]	yc[mm]	zc[mm]	E[N/mm ²]	g[kg/m]	I-1[mm ⁴]	I-2[mm ⁴]
1	2.5725E+02	7.105E+01	2.920E+04	2.920E+04	0.0	0.0	200000	2.0	5.890E+04	2.920E+04

Section values for warping

$w_{min}[mm]$	$w_{max}[mm]$	$CW[mm]$	$CS[mm]$	$ASwyy[mm^6]$	$ASwzz[mm^6]$	$ry[mm]$	$rz[mm]$
-1346E+00	1346E+00	9.712E+01	5.890E+04	0.0	0.0	21.8	76923

Design values of cross section

Mat	A[mm ²]	Ay[mm ²]	Iy[mm ⁴]	Iy[mm ⁴]	yc[mm]	zc[mm]	E[N/mm ²]	g[kg/m]	I-1[mm ⁴]	I-2[mm ⁴]
1	2.5725E+02	7.105E+01	2.920E+04	2.920E+04	0.0	0.0	200000	2.0	5.890E+04	2.920E+04

Solidic - Structural Engineering Scale 2
 SOFSTK 2020-12 AULA - GENERAL CROSS SECTIONS 2020-09-12

Sistema Modulare - Italia, Alvestro

Querschnitte

```

x1[m],y1[m],z1[m],x2[m],y2[m],z2[m] define coordinates relative to coordinate system
kmax[m],kmin[m] define range for iteration loop
a[m] define section thickness
t[m] define section thickness
t1[m],t2[m],t3[m] define thickness
t4[m],t5[m],t6[m] define thickness
t7[m],t8[m],t9[m] define thickness
t10[m] define thickness
    
```

Section values for warping

min[mm2]	max[mm2]	CN[mm6]	CNS[mm6]	ASwyy[mm6]	ASwzz[mm6]	ry[mm]	rz[mm]
-333.33	333.33	5853514	35109	1453	-5379	0.0	-48.5
ASw[mm6]	ASw[mm6]	ASw[mm6]	ASw[mm6]	ASw[mm6]	ASw[mm6]	ASw[mm6]	ASw[mm6]
ASw[mm6]	ASw[mm6]	ASw[mm6]	ASw[mm6]	ASw[mm6]	ASw[mm6]	ASw[mm6]	ASw[mm6]

Design values of cross section

Mat	A[mm2]	Ay[mm2]	Iy[mm4]	yc[mm]	E[N/mm2]	g[kg/m]	I-1[mm4]
Mat	It[mm4]	Az[mm2]	Iz[mm4]	zc[mm]	EN[mm2]		I-2[mm4]
1	2.5725E+02	7.105E+01	2.500E+04	0.0	190176	2.0	5.090E+04
1	1.346E+04	9.712E+01	5.090E+04	0.0	73260		2.928E+04
1			1.431E+01				-89.86

```

x1[m],y1[m],z1[m] define coordinates
x2[m],y2[m],z2[m] define coordinates
t1[m],t2[m],t3[m] define thickness
t4[m],t5[m],t6[m] define thickness
t7[m],t8[m],t9[m] define thickness
t10[m] define thickness
I1[mm4],I2[mm4],I3[mm4] define moment of inertia
I4[mm4],I5[mm4],I6[mm4] define moment of inertia
I7[mm4],I8[mm4],I9[mm4] define moment of inertia
I10[mm4] define moment of inertia
    
```

Design forces and moments

	N[kN]	Vy[kN]	Vz[kN]	M1[kNm]	M2[kNm]	M3[kNm]	My[kNm]	Mz[kNm]	y[mm]	z[mm]	BACK
C1	51.5	14.16	28.24	0.22			0.00	0.17	0.55	0.0	1, a, b
C2	3.4						0.19	0.00	0.0	0.0	COMB
E	51.5	14.16	18.16	0.18	0.21		0.00	0.11	0.18	0.0	0,0
D	49.0	13.49	19.85	0.21			0.00	0.45	0.52	0.0	1, a
D1	3.2						0.45	0.00	0.0	0.0	COMB
D2	50.0	9.67	18.06	0.17	0.20		0.00	0.20	0.17	0.0	0,0

```

* C1 - plastic moment design value (1) (1) (1) (1) (1) (1) (1) (1) (1) (1) (1) (1)
* D1 - plastic moment design value (1) (1) (1) (1) (1) (1) (1) (1) (1) (1) (1) (1)
* E - elastic characteristic design value (1) (1) (1) (1) (1) (1) (1) (1) (1) (1) (1) (1)
* G - elastic characteristic design value (1) (1) (1) (1) (1) (1) (1) (1) (1) (1) (1) (1)
* H - elastic characteristic design value (1) (1) (1) (1) (1) (1) (1) (1) (1) (1) (1) (1)
* I - elastic characteristic design value (1) (1) (1) (1) (1) (1) (1) (1) (1) (1) (1) (1)
    
```

Additional design data

Mat	periphery-0/I	def	t-min	t-max	that-p	that-y	that-z	that-yz	yB	zB
	[mm2/m]	[mm/m]	[mm]	[mm]	[kg/m2/m]	[kg/m2/m]	[kg/m2/m]	[kg/m2/m]	[mm]	[mm]
1	315065.2		3.5	3.5	0.000	0.000	0.000	0.000	0.0	0.0

```

* I - plastic moment design value (1) (1) (1) (1) (1) (1) (1) (1) (1) (1) (1) (1)
* J - plastic moment design value (1) (1) (1) (1) (1) (1) (1) (1) (1) (1) (1) (1)
* K - plastic moment design value (1) (1) (1) (1) (1) (1) (1) (1) (1) (1) (1) (1)
* L - plastic moment design value (1) (1) (1) (1) (1) (1) (1) (1) (1) (1) (1) (1)
* M - plastic moment design value (1) (1) (1) (1) (1) (1) (1) (1) (1) (1) (1) (1)
    
```

5 Riepilogo risultati vetro e profilo

5.1 Massima altezza ammissibile del parapetto per solo carico orizzontale h_k di spinta sul colmo

Nei seguenti grafici si vede la massima altezza ammissibile del parapetto per solo carico orizzontale di spinta sul colmo in direzione caduta nel vuoto LCA e contro caduta nel vuoto LCB considerando il punto dove la curva dello sfruttamento mostra il valore di 1.0.

FTG...fully tempered glas = vetro temprato

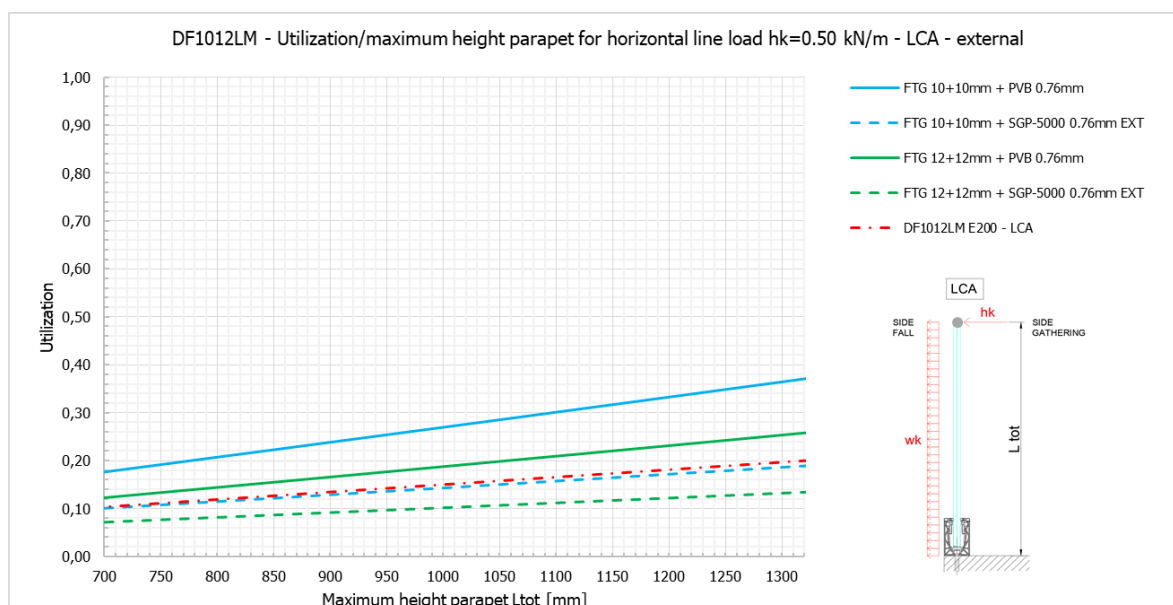

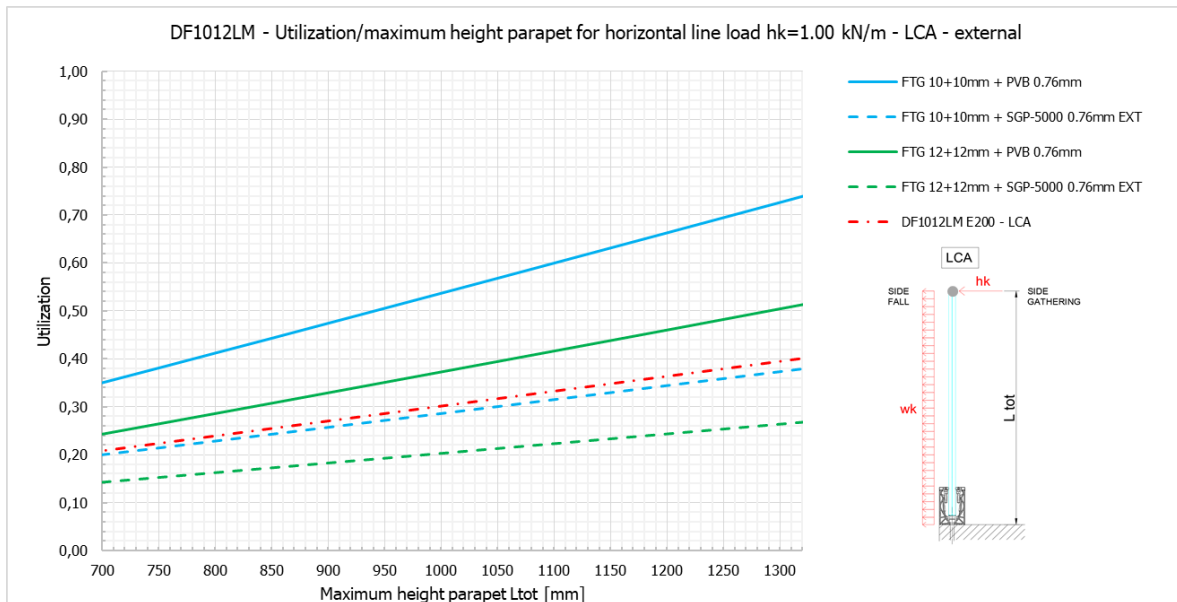
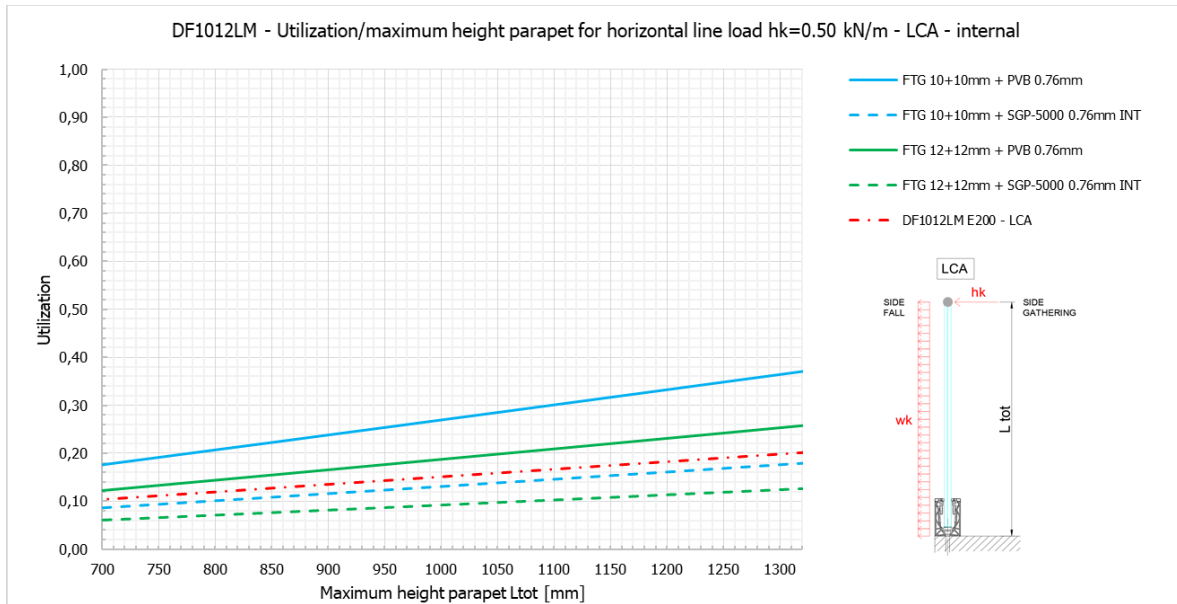

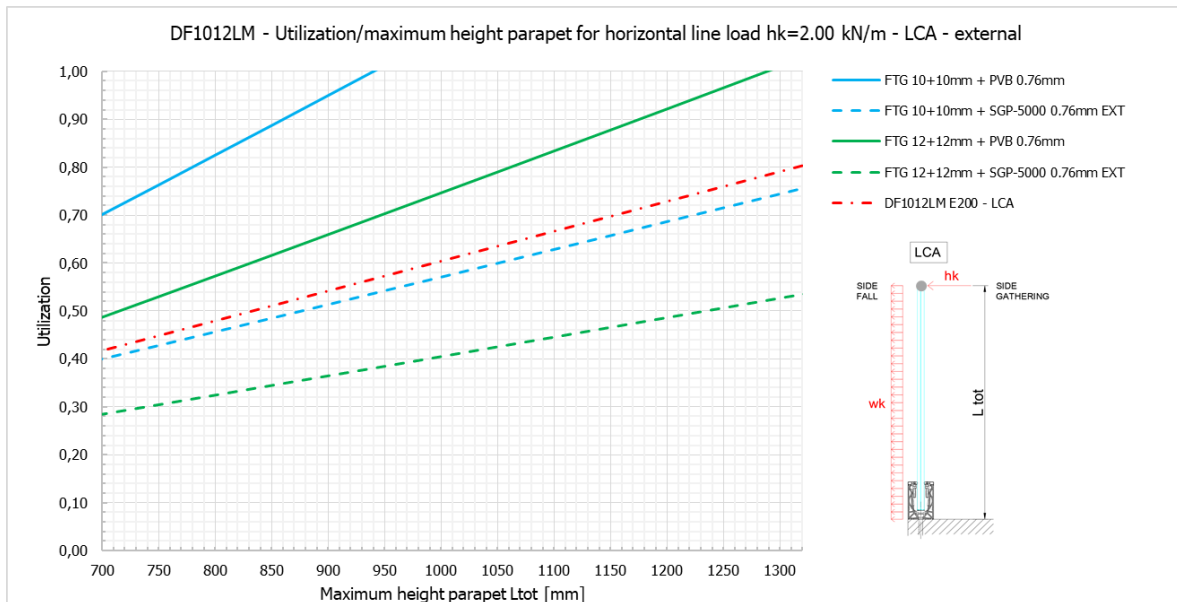
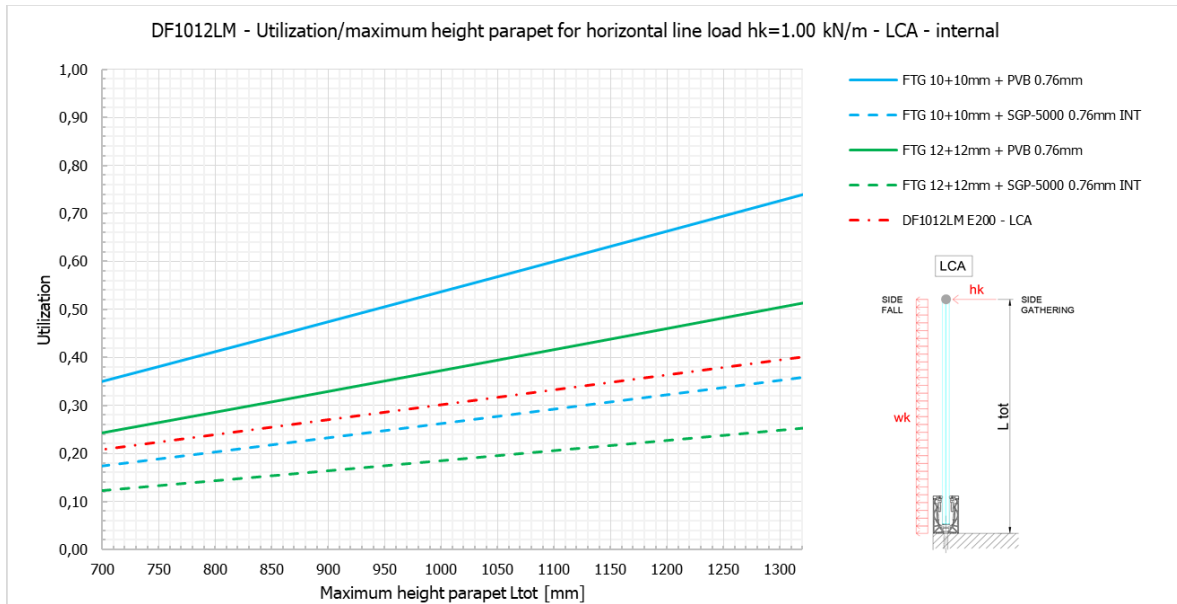

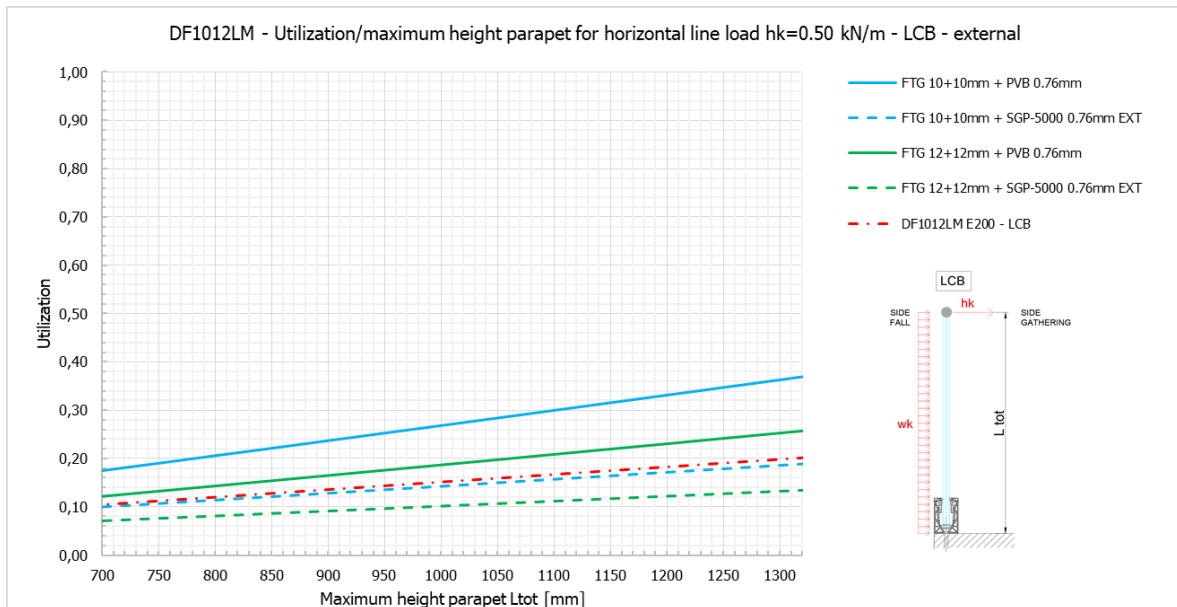
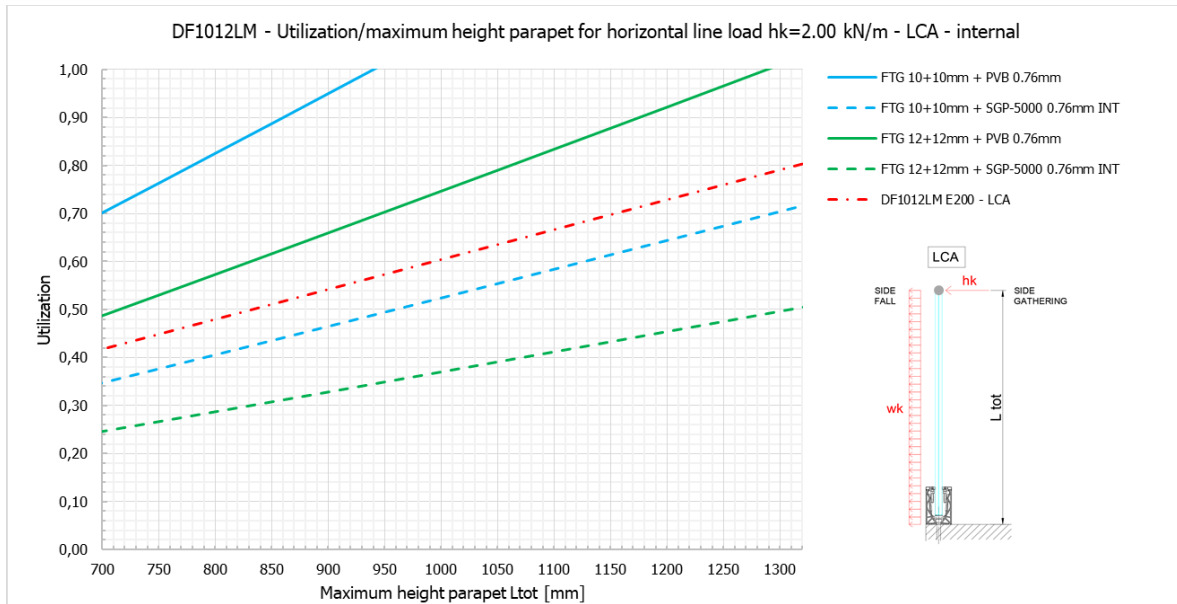

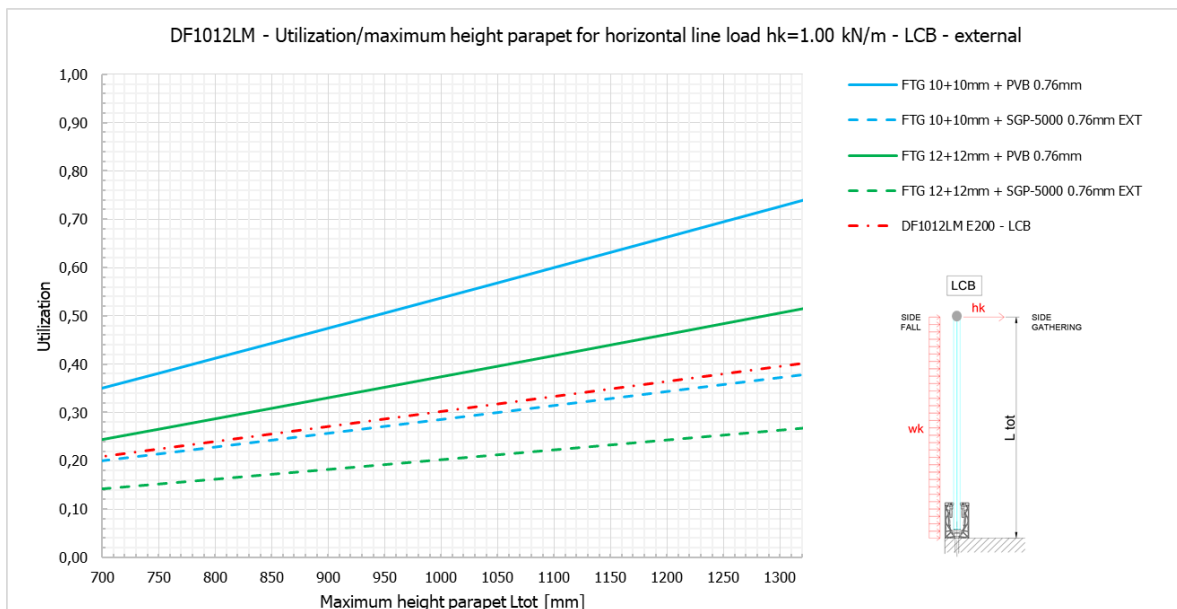
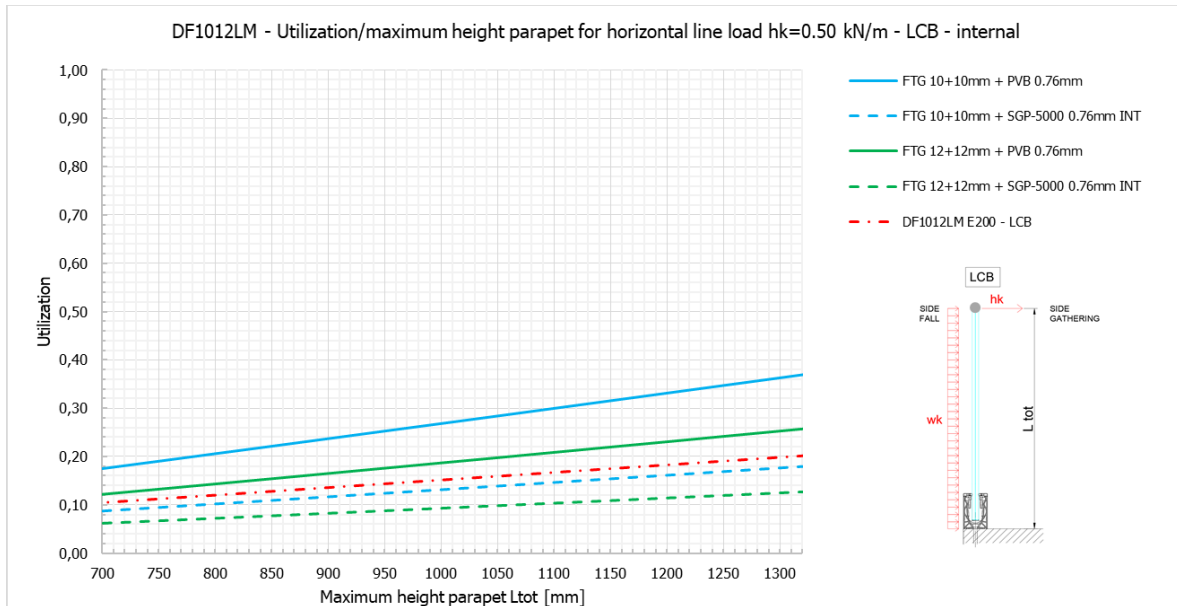

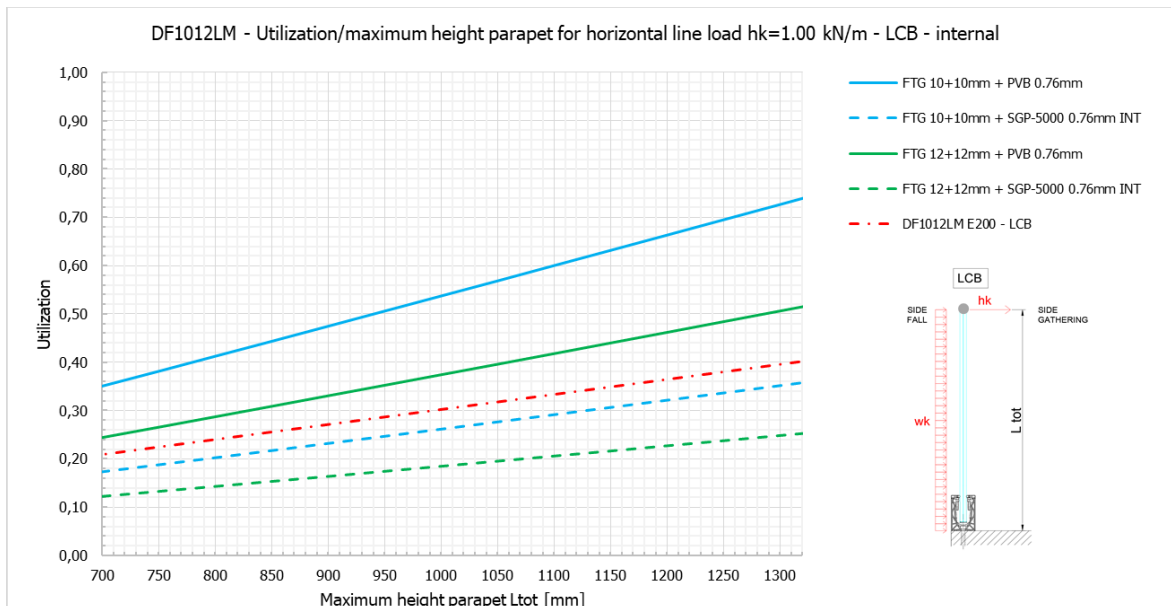

5.2 Massimo carico di vento wk aggiuntivo al carico di spinta orizzontale hk

FTG...fully tempered glas = vetro temprato

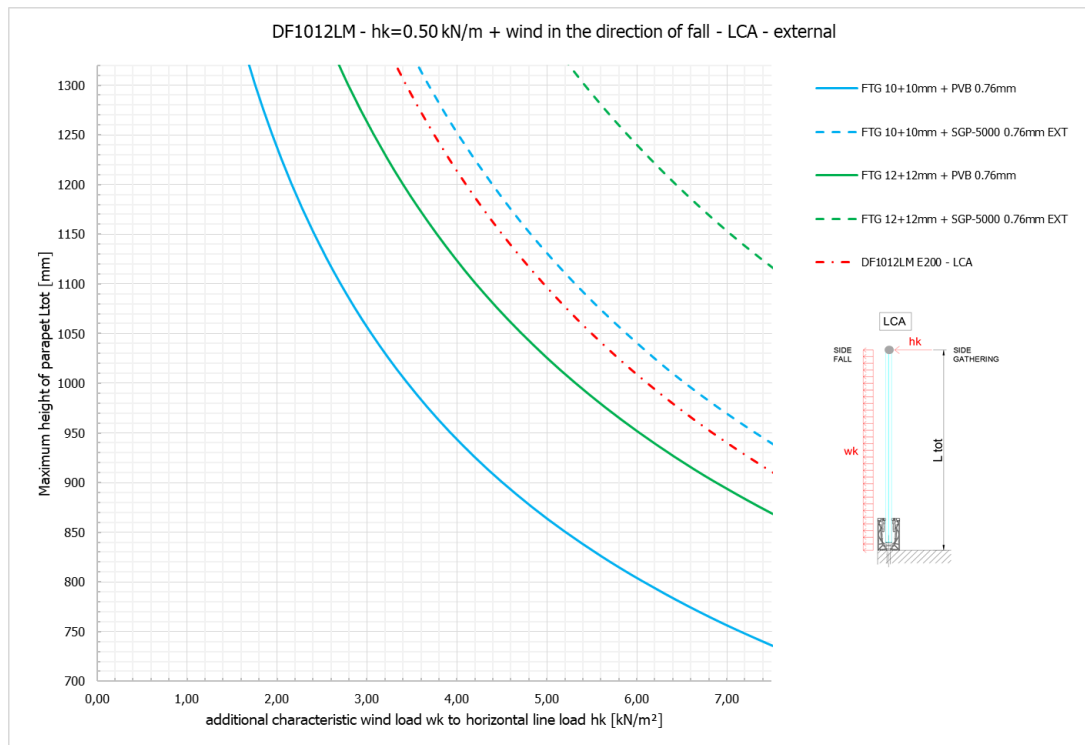

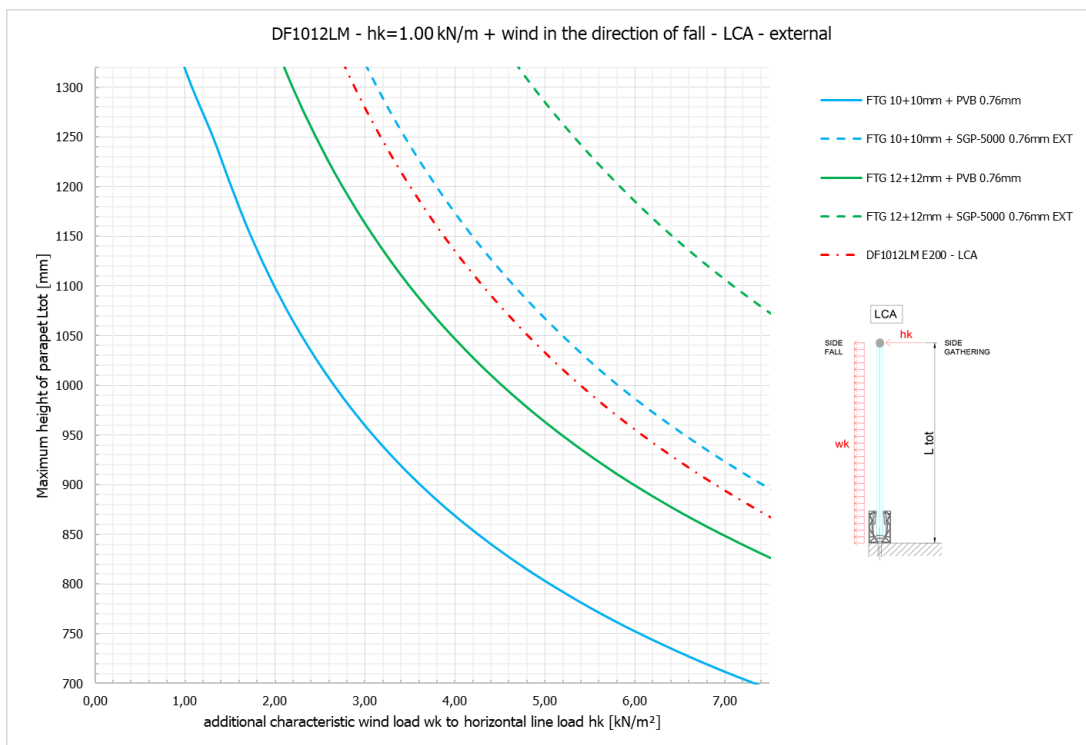
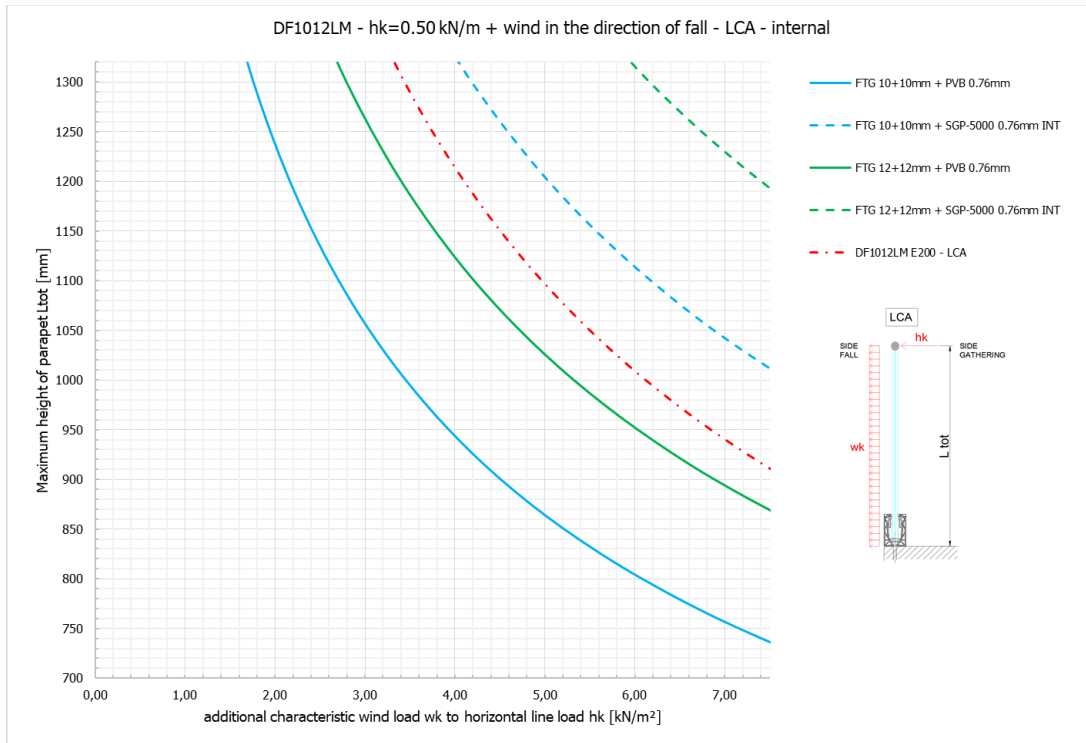

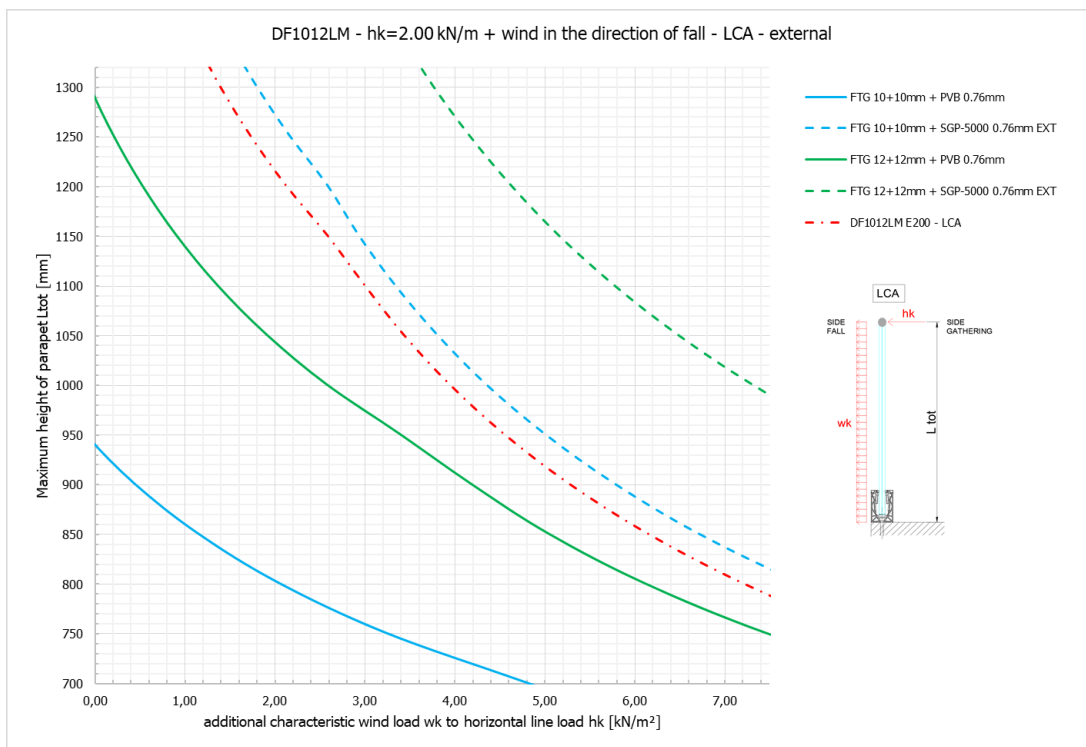
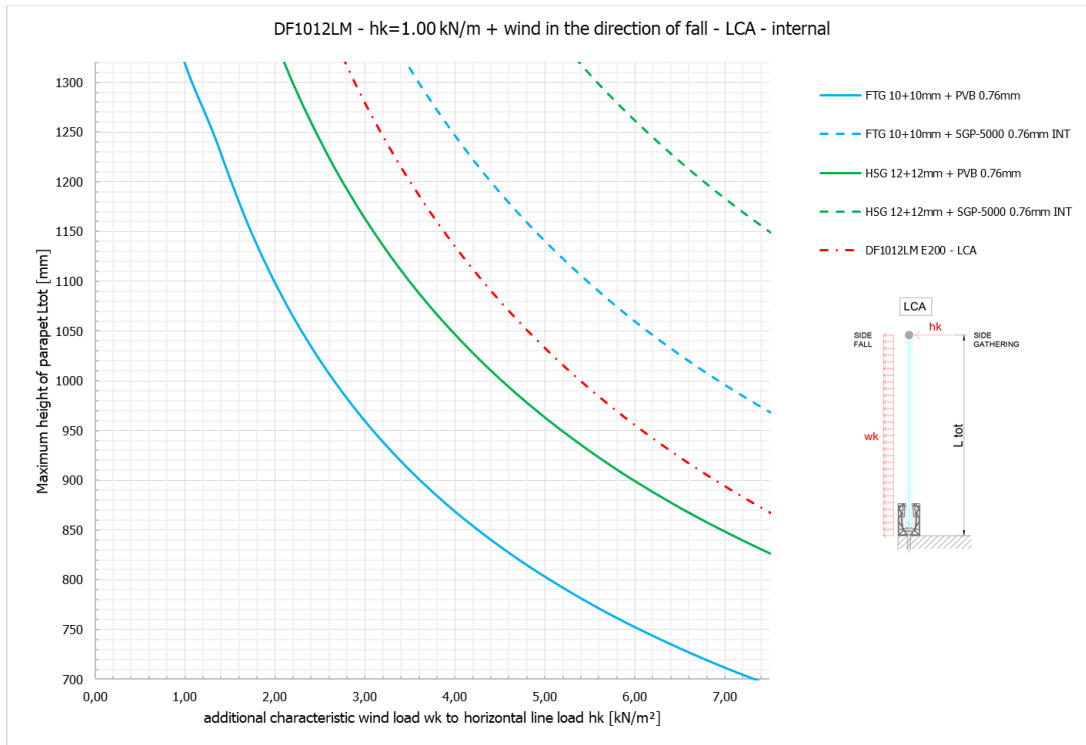

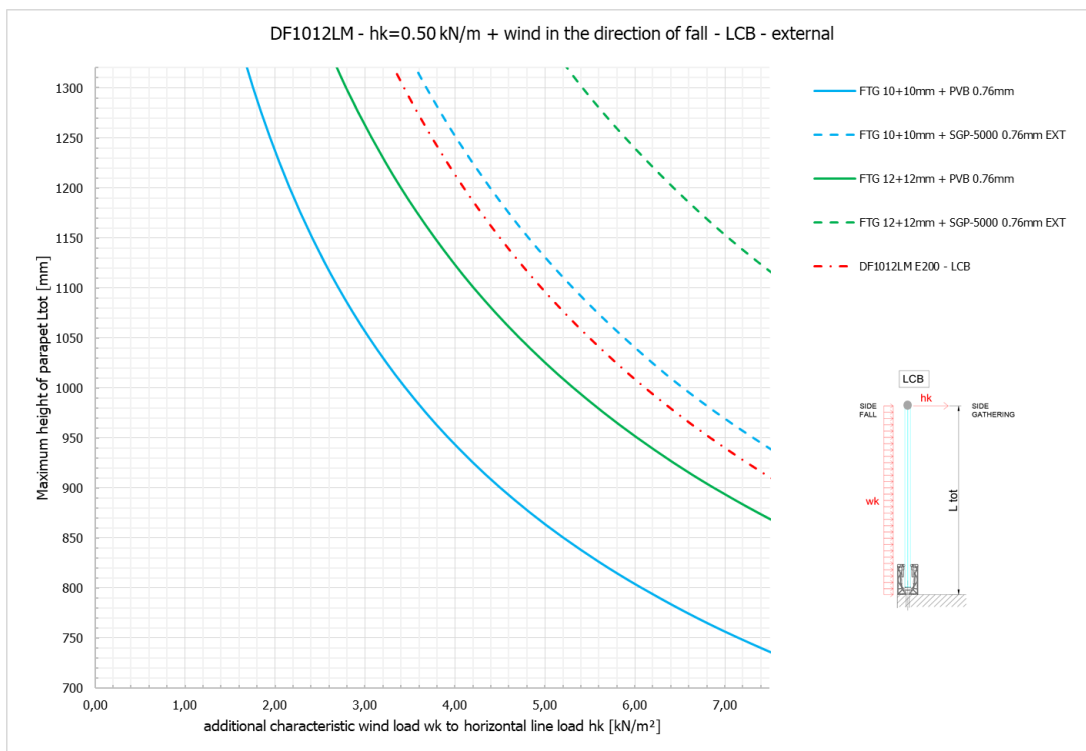
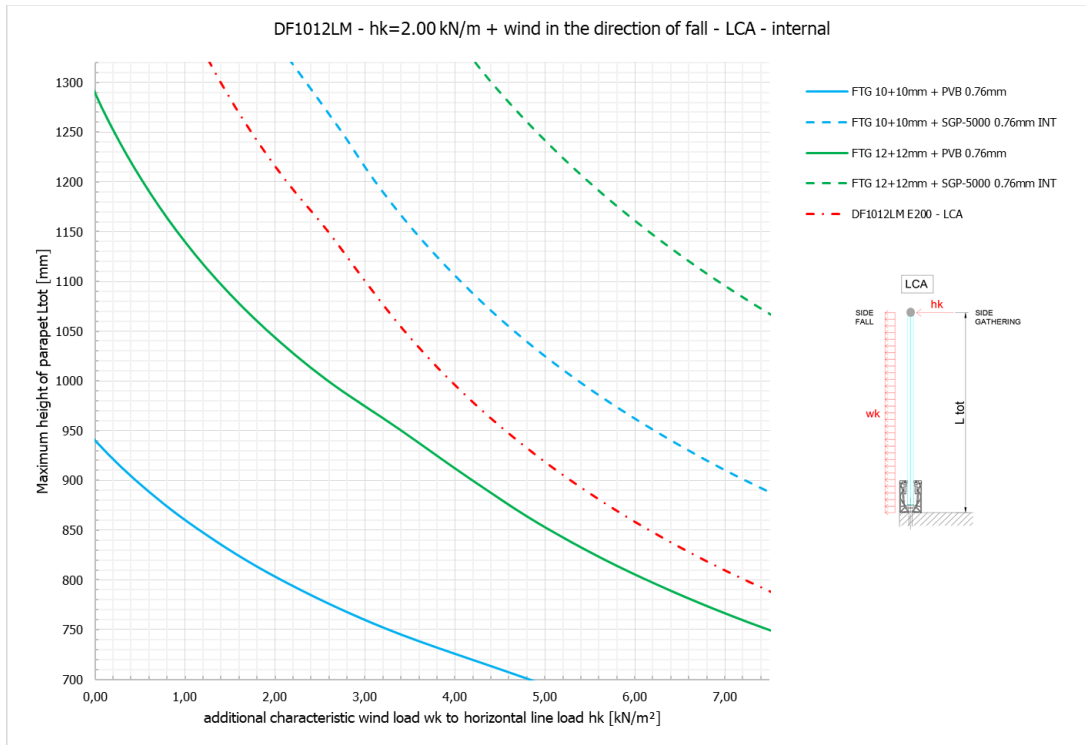

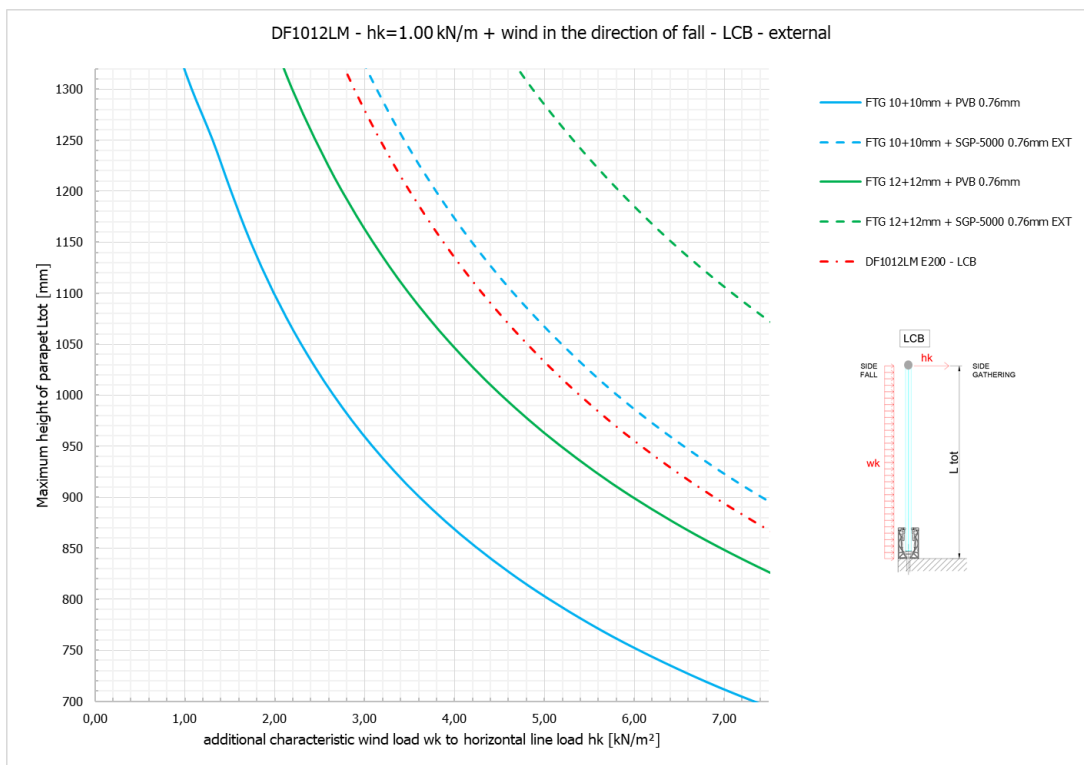
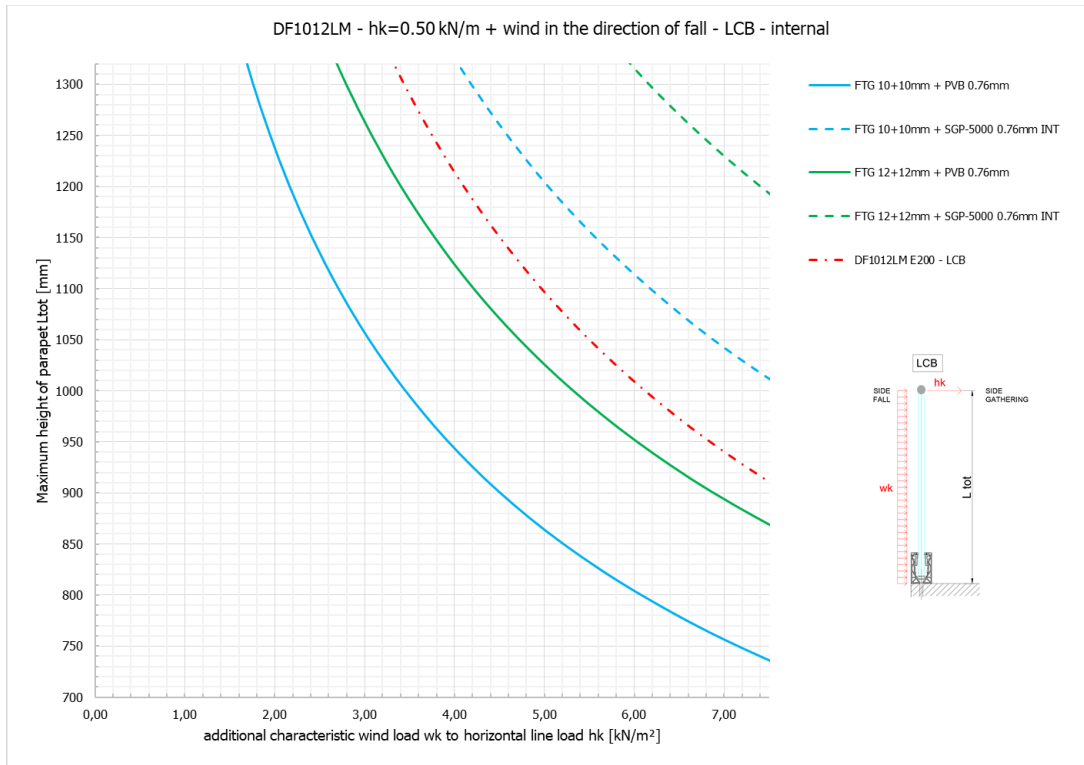

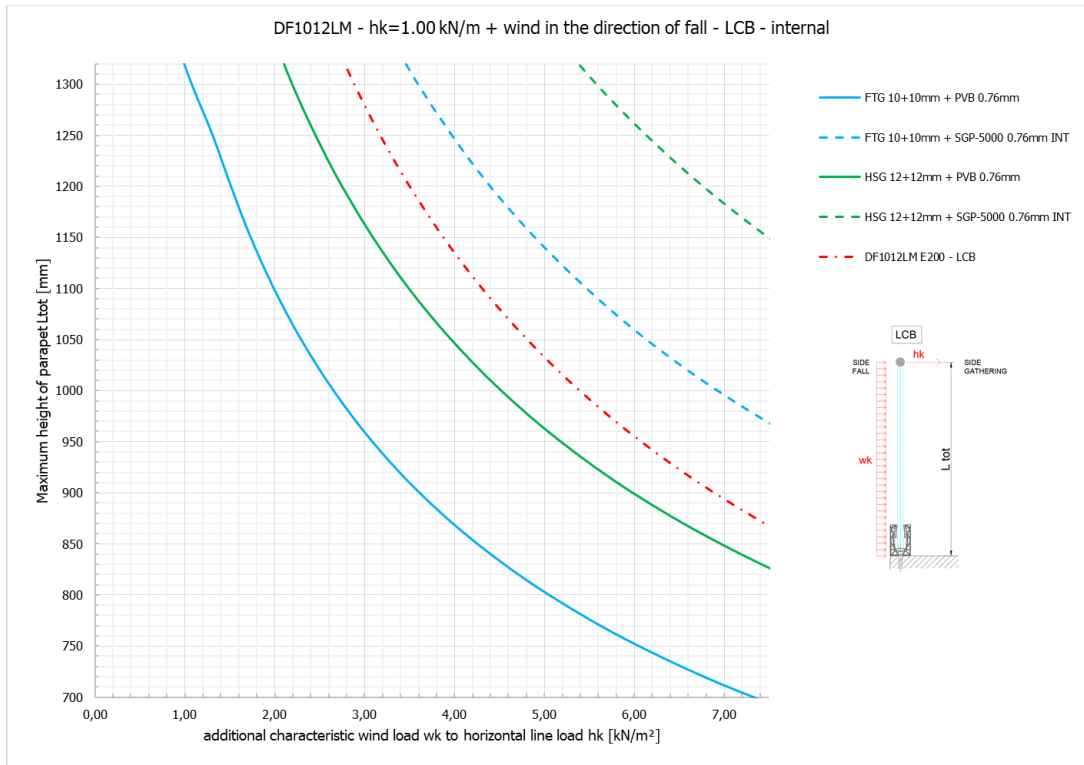

5.3 Reazioni sugli ancoraggi

Di seguito sono riportate le forze di reazione all'ancoraggio (componenti di compressione e tensione) e la formula per il loro calcolo per una distanza di ancoraggio di $e = 200\text{mm}$ nonché per entrambe le direzioni di carico LCA e LCB.

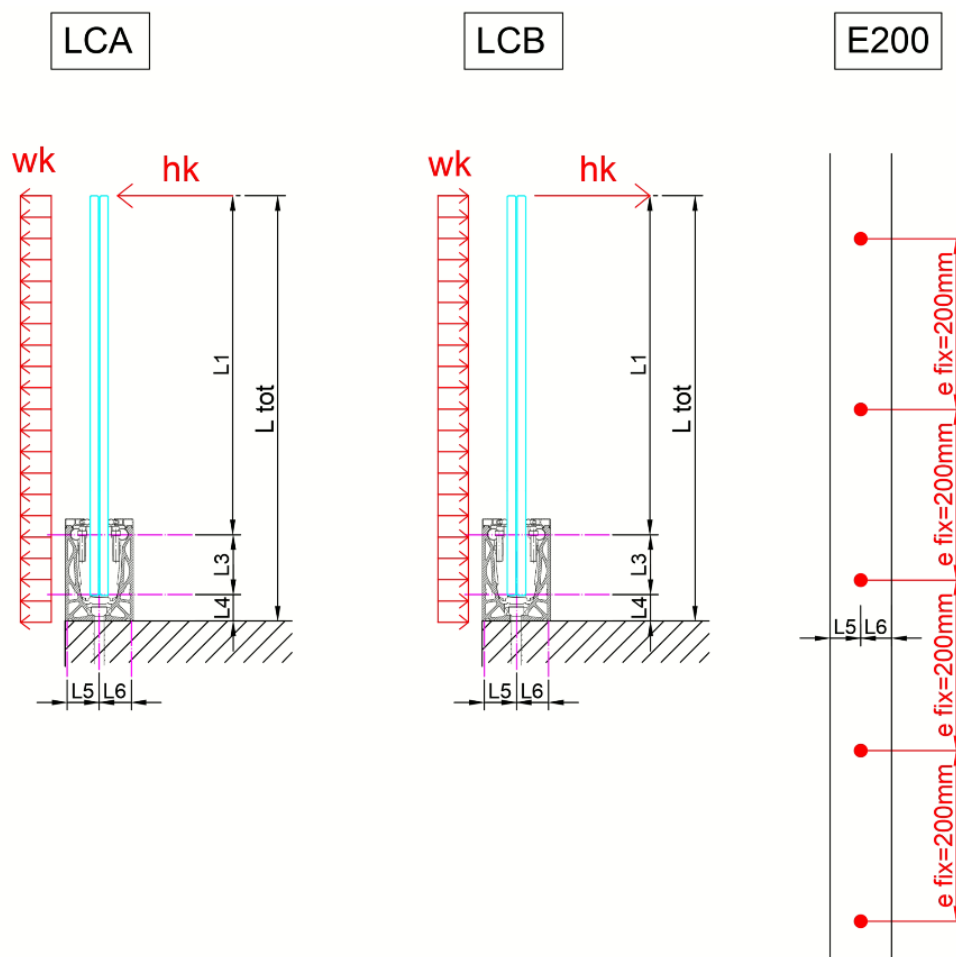

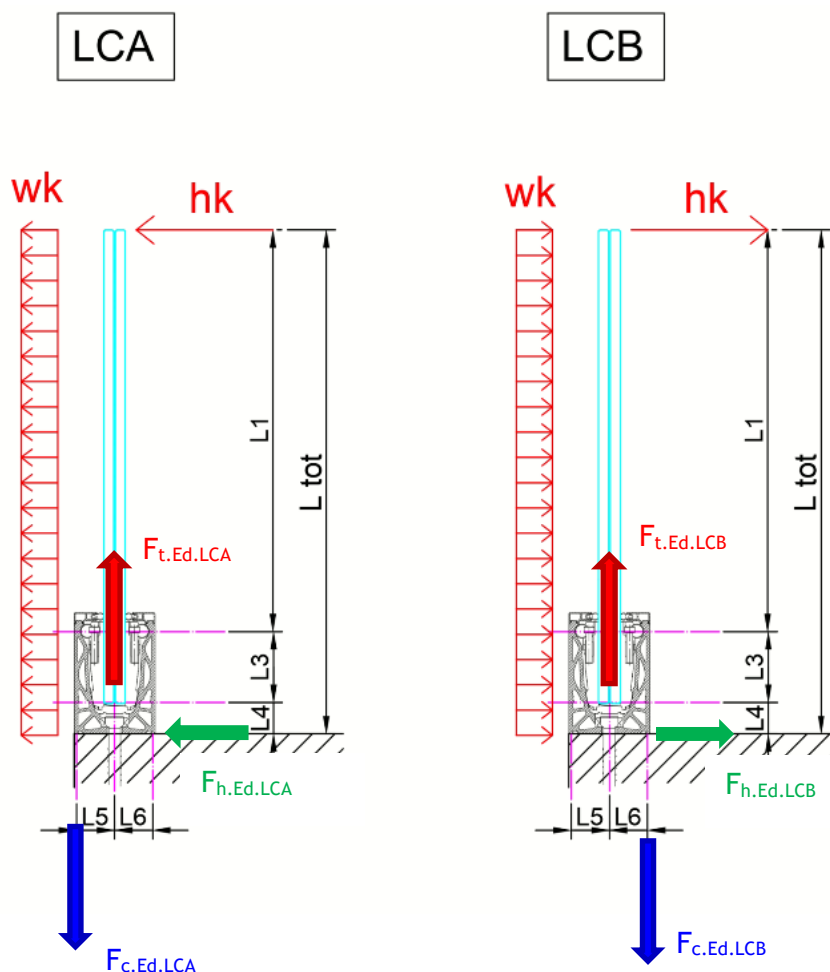

Per una distanza die fissaggi di $e=200\text{mm}$:

$$F_{t.Ed.LCA.e200} = e * \max\left(\frac{1.5 * hk * L_{tot} + 1.5 * 0.6 * wk * \frac{L_{tot}^2}{2}}{L_5}; \frac{1.5 * 0.7 * hk * L_{tot} + 1.5 * wk * \frac{L_{tot}^2}{2}}{L_5}\right)$$

$$F_{h.Ed.LCA.e200} = e * \max(1.5 * hk + 1.5 * 0.6 * wk * L_{tot}; 1.5 * 0.7 * hk + 1.5 * wk * L_{tot})$$

$$\text{con } e = 200 \text{ mm} + L_5 = 37.60 \text{ mm}$$

$$F_{c.Ed.LCA.e200} = F_{t.Ed.LCA.e200}$$

$$F_{t.Ed.LCB.e200} = e * \max\left(\frac{1.5 * hk * L_{tot} + 1.5 * 0.6 * wk * \frac{L_{tot}^2}{2}}{L_6}; \frac{1.5 * 0.7 * hk * L_{tot} + 1.5 * wk * \frac{L_{tot}^2}{2}}{L_6}\right)$$

$$F_{h.Ed.LCB.e200} = e * \max(1.5 * hk + 1.5 * 0.6 * wk * L_{tot}; 1.5 * 0.7 * hk + 1.5 * wk * L_{tot})$$

$$\text{con } e = 200 \text{ mm} + L_6 = 37.60 \text{ mm}$$

$$F_{c.Ed.LCB.e200} = F_{t.Ed.LCB.e200}$$

Esempio di calcolo:

Per $e=200\text{mm}$, $L_{\text{tot}}=1201\text{mm}$, $h_k=1.00\text{ kN/m}$ e $w_k=3.39\text{ kN/m}^2$

$F_{tEd.LCA.e200}$

$= 0.200m$

$$* \max \left(\frac{1.5 * 1.00 \frac{kN}{m} * 1.201m + 1.5 * 3.39kN/m^2 * 0.60 * \frac{(1.201m)^2}{2}}{0.0376m}; \frac{1.5 * 1.00kN/m * 0.7 * 1.201m + 1.5 * 3.39kN/m^2 * \frac{(1.201m)^2}{2}}{0.0376m} \right)$$

$=26.22\text{ kN}$

$$F_{hEd.LCA.e200} = 0.200m * \max \left(1.5 * 1.00 \frac{kN}{m} + 1.5 * 0.6 * 3.39kN/m^2 * 1.201m; 1.5 * 0.7 * 1.00 \frac{kN}{m} + 1.5 * 3.39kN/m^2 * 1.201m \right)$$

$=1.43\text{ kN}$

5.4 Massima larghezza lastra in vetro per rottura di un elemento

In seguito, è indicato la larghezza massima di una lastra in vetro in caso di rottura di un elemento in vetro. La larghezza del vetro deriva sia dalla resistenza del corrimano, che deve trasferire il carico orizzontale lineare alle lastre vicine intatte, che dalla resistenza stessa delle lastre vicine, che devono trasferire il carico dal corrimano con un angolo di 45 ° al profilo di base - vedi anche il capitolo 4.1.3.

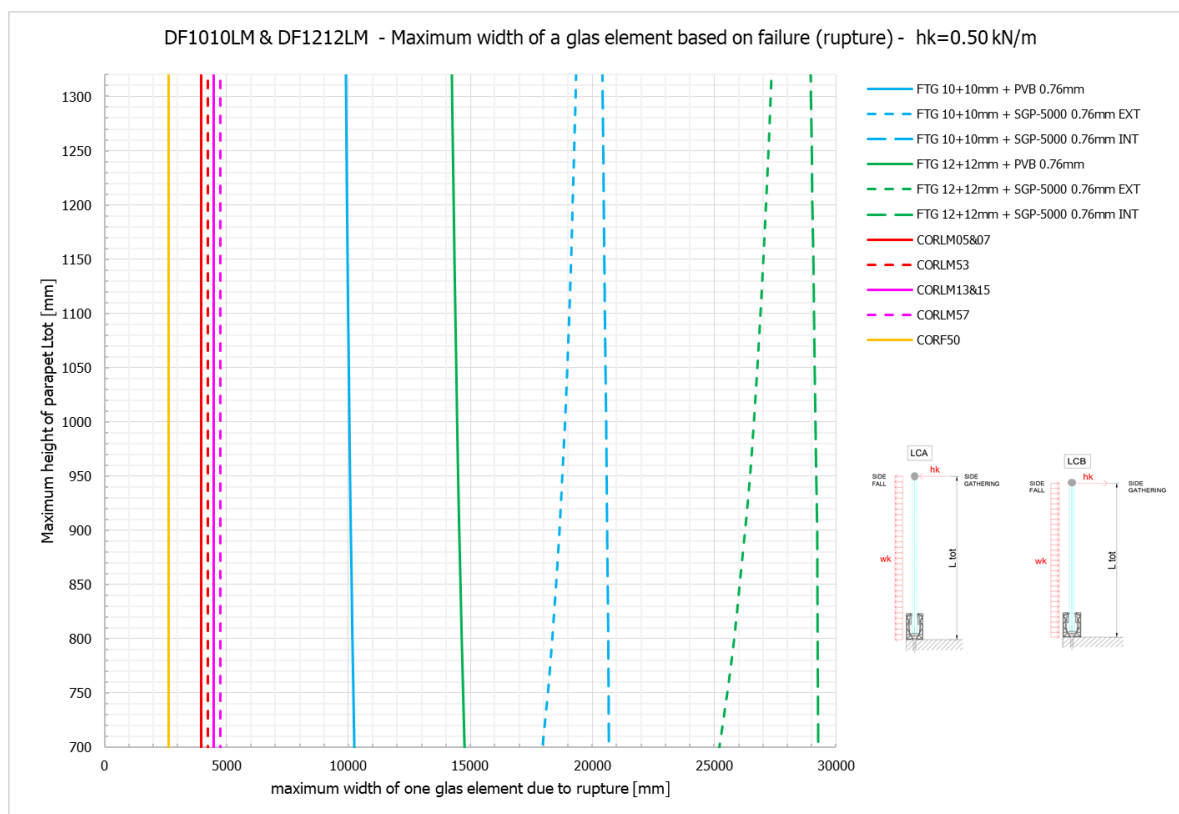

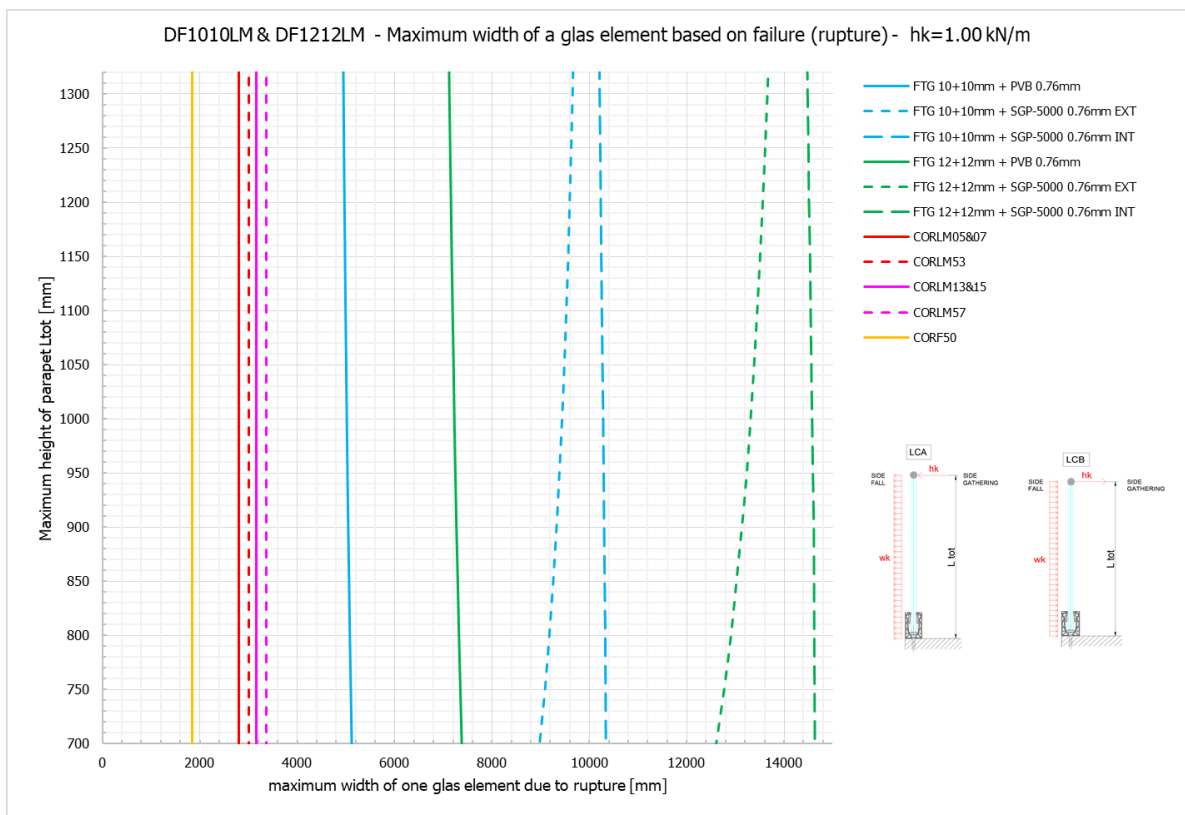
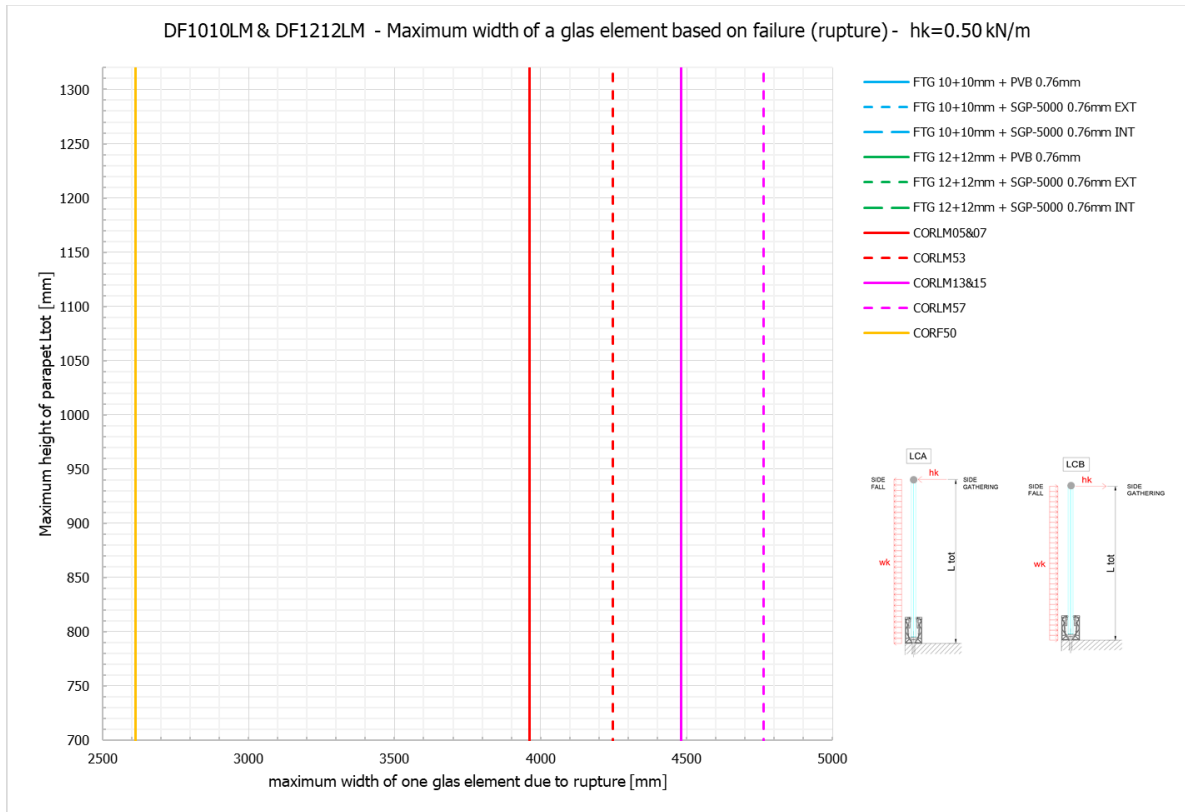

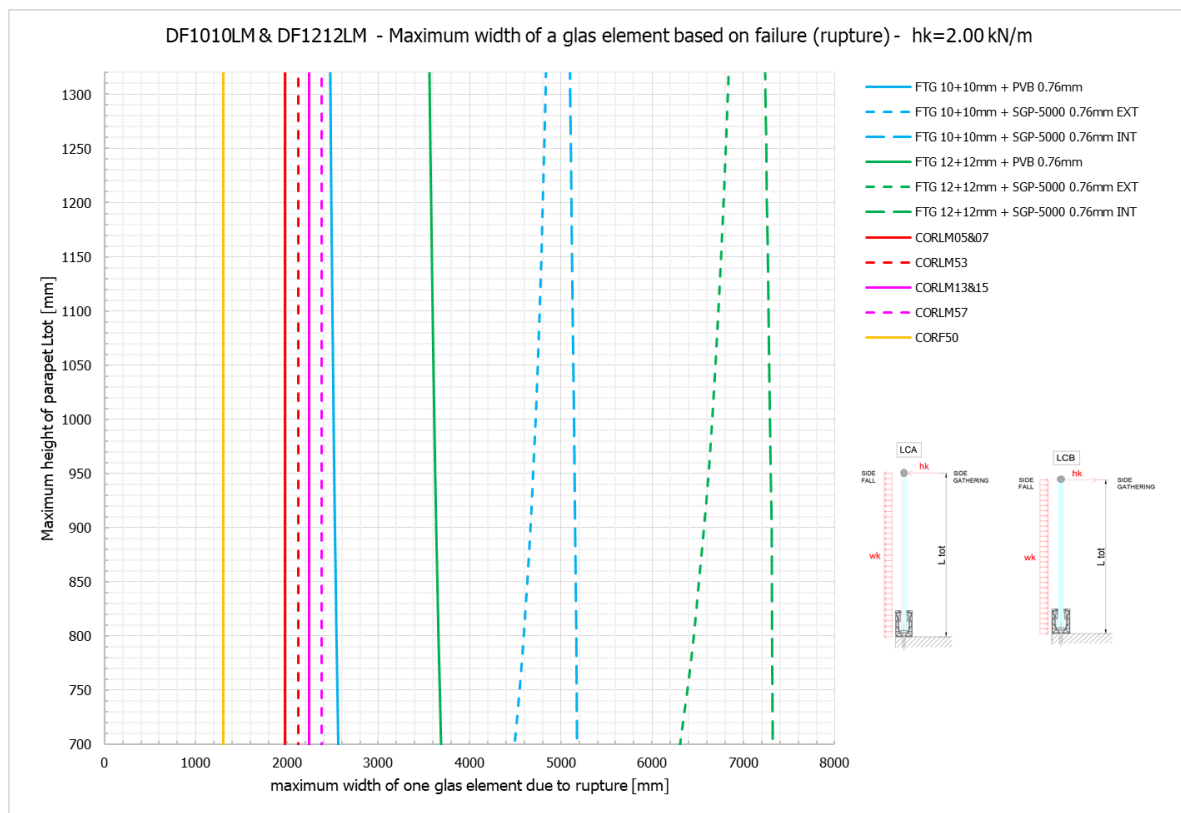
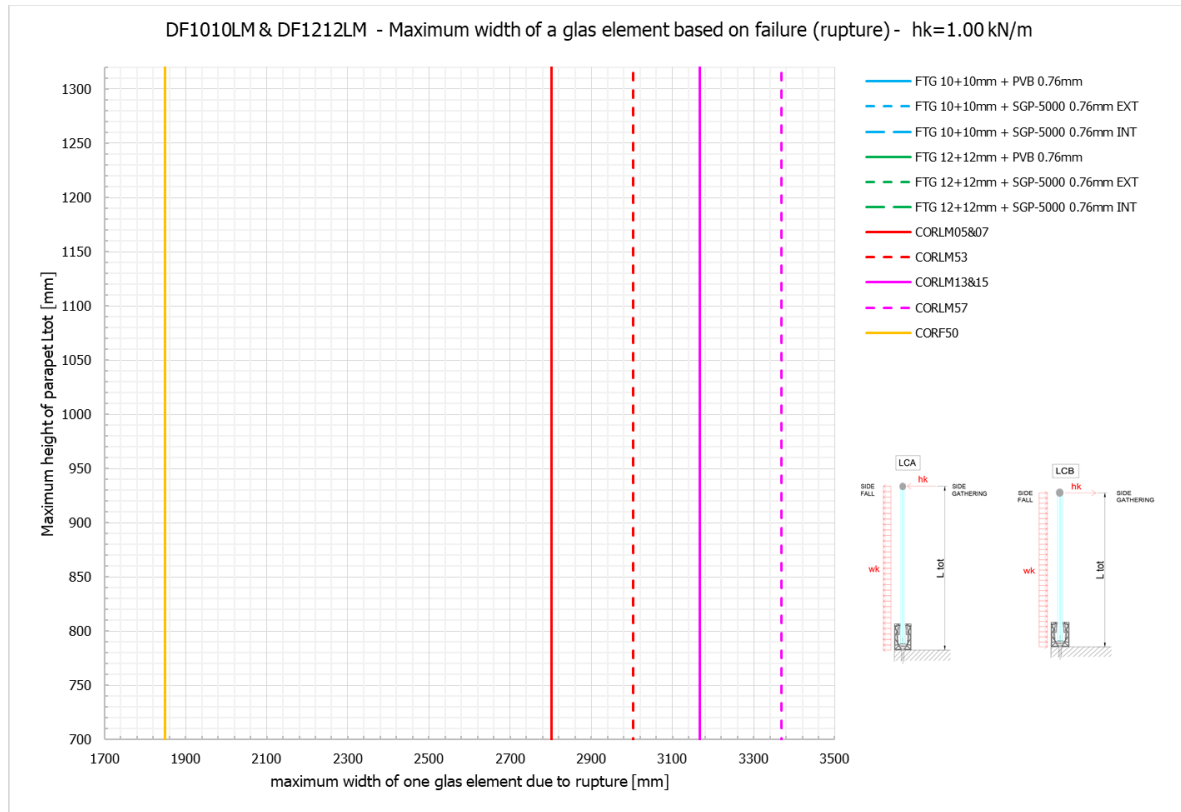

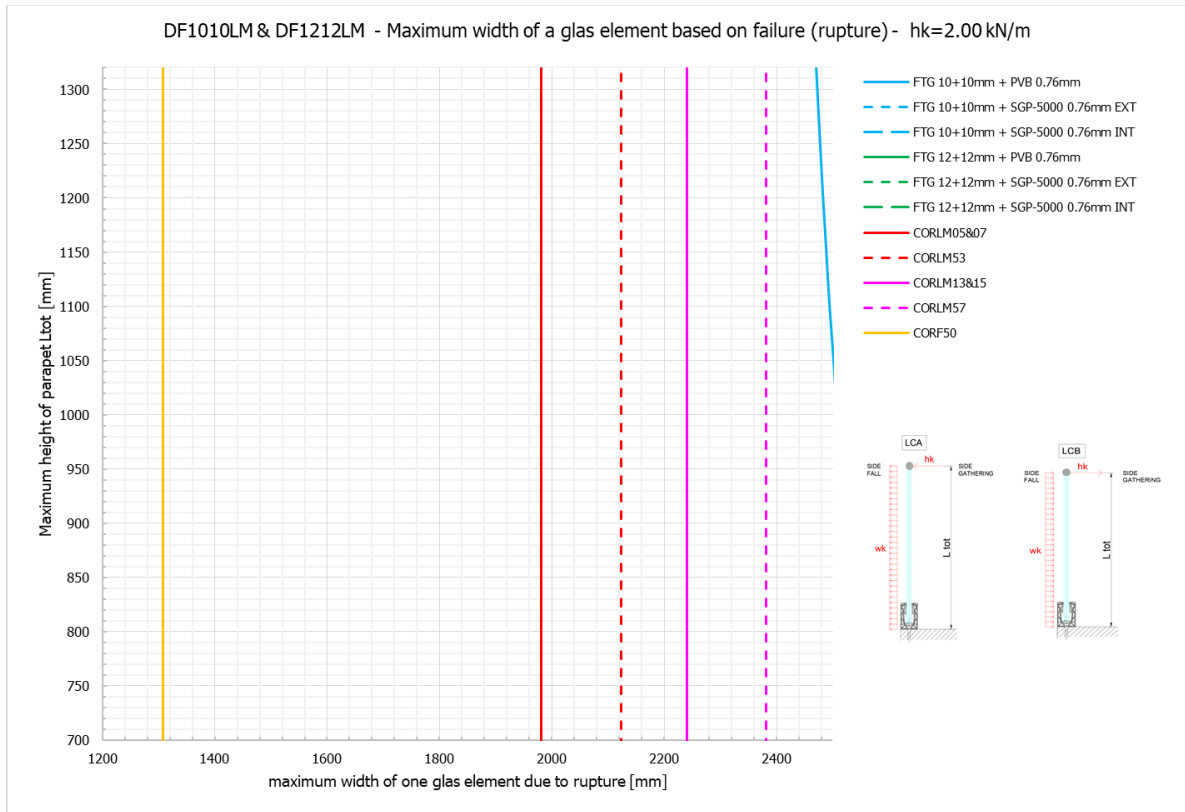

5.5 Conclusioni

Si riporta in tabella una sintesi di possibili soluzioni di applicazione per sistema DEFENDER DF1010LM e DF1212LM per diverse tipologie di lastre di vetro.

DF1010LM					
Applicazione	Composizione lastre	Interasse ancorasse in mm	Altezza massima del parapetto (L_{tot}) in mm		
			Cat. A, B1* $hk=0,5$ kN/m	Cat. B2, B3, C1-C4, D, E* $hk=1,0$ kN/m	Cat. C5, C6* $hk=2,0$ kN/m
Interno 20° C senza pressione del vento ¹	1010.2 PVB Vetri temprati (FTG)	200	1300	1300	940
	1010.2 Sentryglas® Vetri temprati (FTG)	200	1300	1300	1300
Esterno 50° C più pressione del vento ²	1010.2 PVB Vetri temprati (FTG)	200	1300	1300	860
	1010.2 Sentryglas® Vetri temprati (FTG)	200	1300	1300	1300

Schema rappresentativo del sistema e della direzione dei carichi per le conclusioni riportate in tabella

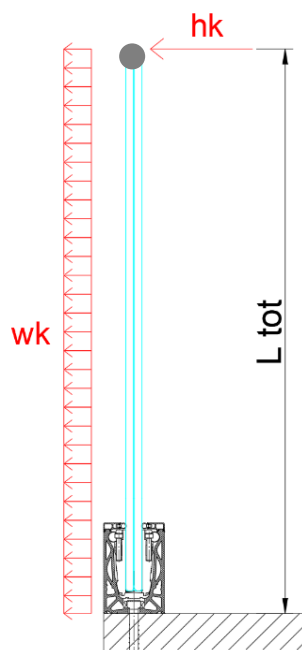

* secondo DIN EN 1991-1-1, tabella 6.12, vedi anche ulteriori classi di uso

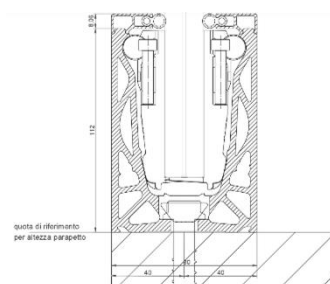

¹ In queste soluzioni sono proposte le verifiche per spinta antropica non combinata con il carico del vento.

² Per installazioni in ambiente esterno è considerata la combinazione più gravosa di pressione del vento caratteristica pari a 1,0 kN/m² di e spinta antropica per varie categorie di utilizzo. Entrambe le azioni sono considerate agenti contemporaneamente e le verifiche sono fatte per una temperatura di 50° C. Per combinazioni di carico o pressioni del vento differenti e per la direzione secondaria, riferirsi alle tabelle e grafici nelle sezioni precedenti.

DF1212LM					
Applicazione	Composizione lastre	Interasse ancoranti in mm	Altezza massima del parapetto (L_{tot}) in mm		
			Cat. A, B1* hk=0,5 kN/m	Cat. B2, B3, C1- C4, D, E * hk=1,0 kN/m	Cat. C5, C6 * hk=2,0 kN/m
Interno 20° C senza pressione del vento ¹	1212.2 PVB Vetri temprati (FTG)	200	1300	1300	1290
	1212.2 Sentryglas® Vetri temprati (FTG)	200	1300	1300	1300
Esterno 50° C più pressione del vento ²	1212.2 PVB Vetri temprati (FTG)	200	1300	1300	1140
	1212.2 Sentryglas® Vetri temprati (FTG)	200	1300	1300	1300

Schema rappresentativo del sistema e della direzione dei carichi per le conclusioni riportate in tabella

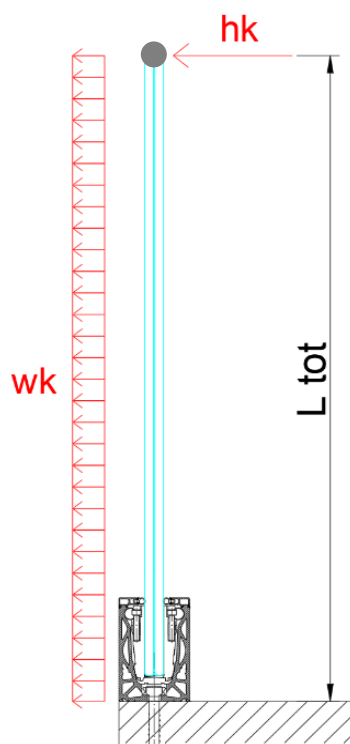

* secondo DIN EN 1991-1-1, tabella 6.12, vedi anche ulteriori classi di uso

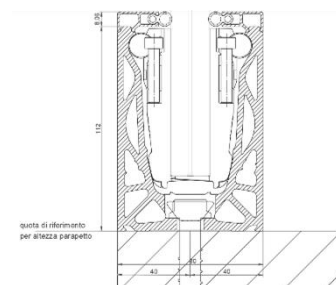

¹ In queste soluzioni sono proposte le verifiche per spinta antropica non combinata con il carico del vento.

² Per installazioni in ambiente esterno è considerata la combinazione più gravosa di pressione del vento caratteristica pari a 1,0 kN/m² di e spinta antropica per varie categorie di utilizzo. Entrambe le azioni sono considerate agenti contemporaneamente e le verifiche sono fatte per una temperatura di 50° C. Per combinazioni di carico o pressioni del vento differenti e per la direzione secondaria, riferirsi alle tabelle e grafici nelle sezioni precedenti.

Si riporta in tabella per sistema DEFENDER DF1010LM / DF1212LM la sintesi della massima larghezza di una lastra in vetro in come valore minimo della verifica rottura di una lastra e resistenza corrimano:

DF1010LM / DF1212LM					
Applicazione	Composizione lastre	Tipo di corrimano	Massima larghezza di una lastra in vetro in [mm] come valore minimo della verifica rottura di una lastra e resistenza corrimano		
			Cat. A, B1* hk=0,5 kN/m	Kat. B2, B3, C1-C4, D, E * hk=1,0 kN/m	Kat. C5, C6 * hk=2,0 kN/m
Interno 20°C senza pressione del vento + Esterno 50°C più pressione del vento	1010.2 PVB Vetri temprati (FTG)	CORLM 05 & 07	3960	2800	1980
	+ 1010.2 Sentryglas® Vetri temprati (FTG)	CORLM 53	4250	3000	2120
	+ 1212.2 PVB Vetri temprati (FTG)	CORLM 13 & 15	4480	3170	2240
	+ 1212.2 Sentryglas® Vetri temprati (FTG)	CORLM 57	4760	3370	2380
		CORF 50	2620	1850	1310

Schema rappresentativo del sistema e della direzione dei carichi per le conclusioni riportate in tabella

* secondo DIN EN 1991-1-1, tabella 6.12, vedi anche ulteriori classi di uso

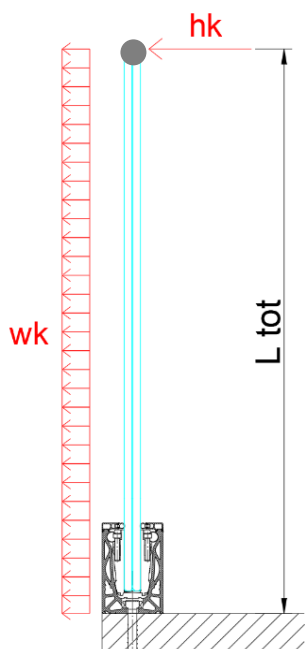

CORF50 (AISI 316=1.4401)

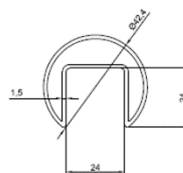

CORLM05 & CORLM07 (EN AW 6060 T6)

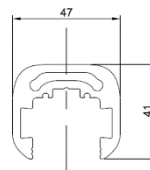

CORLM53 (EN AW 6060 T6)

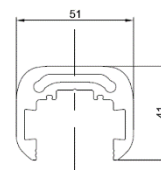

CORLM13 & CORLM15 (EN AW 6060 T6)

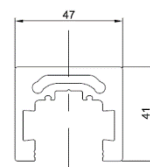

CORLM57 (EN AW 6060 T6)

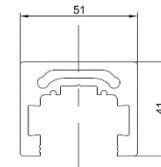

Allegato

Risultati calcolo del vetro con SJ Mepla

Sistema DF1010LM - vetro temprato 10+10 con 0.76mm PVB

Di seguito è riportato un esempio del calcolo del vetro con il software SJ Mepla per una lastra in vetro 10 + 10 temprato + 0,76 mm PVB sia per un carico unitario $h_u = 1.0 \text{ kN/m}$ sul bordo superiore della vetrata sia per un carico superficiale unitario $w_u = 1.0 \text{ kN/m}^2$ sull'intera area della lastra. Tutti i calcoli delle altre stratigrafie ed altezze del vetro vengono eseguite in modo simile solo con una variazione dell'altezza del vetro e del modulo elastico dell'intercalare.

Per DF1212LM in modo simile.

Projekt: PVB_DE_10+10 - PVB_DE_1kN-m_10+10_1000

04.03.2020

Seite: 1

SJ MEPLA Calculation protocol:

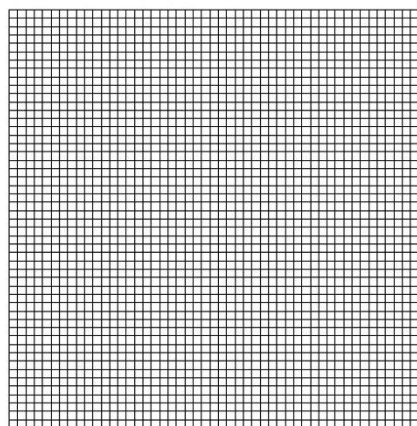
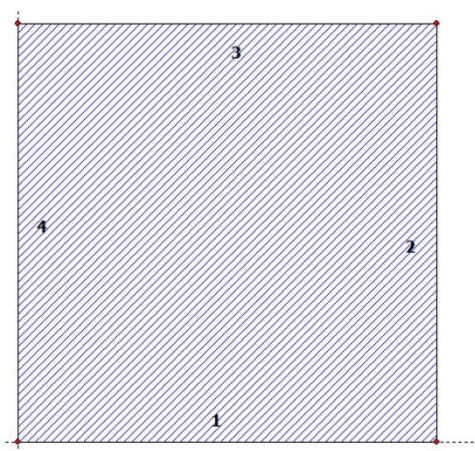

Geometry:

Edge	Borderpoint		Arccenter		Direction of rotation
	mm	mm	mm	mm	+/-
1	0.00	0.00			
2	1000.00	0.00			

Dieser Ausdruck wurde durch das Programm SJ MEPLA erstellt. Copyright 2000-2017 by SJ Software GmbH Aachen.

Projekt: PVB_DE_10+10 - PVB_DE_1kN-m_10+10_1000

04.03.2020
Seite: 2

3	1000.00	1000.00
4	0.00	1000.00

Supports:

Edge supports:

Edge	Type of supports
1	w, u, v, φ, θ: fixed (all d.o.f supported and clamped)

Spring supports:

Package	Layer	x	y	z	C x	C y	C z	C φ	C θ
		mm	mm	mm	N/mm	N/mm	N/mm	Nmm	Nmm
1	1	0.0	0.0	0.0	1.000e+00	1.000e+00	0.000e+00	0.00e+00	0.00e+00
1	1	1000.0	0.0	0.0	0.000e+00	1.000e+00	0.000e+00	0.00e+00	0.00e+00

Layers:

Layer order:

Package	Layer	Description
1	3	ESG
1	2	PVB Langzeitbelastung
1	1	ESG

Mechanical properties:

Package	Layer	E-mod.	ν	Thickness	Density	αt	ΔT
		N/mm ²		mm	kg/m ³	1/K	K
1	3	70000.00	0.23	10.00	2550.00	1.0000e-05	0.00
1	2	0.00	0.50	0.76	1070.00	8.0000e-05	0.00
1	1	70000.00	0.23	10.00	2550.00	1.0000e-05	0.00

Loads:

Line loads:

Package	-- from --	--- to ---	qx	qy	qz
	x	y	x	y	
			N/mm	N/mm	N/mm
1	0.00	1000.00	1000.00	1000.00	0.00

Dieser Ausdruck wurde durch das Programm SJ MEPLA erstellt. Copyright 2000-2017 by SJ Software GmbH Aachen.

Projekt: PVB_DE_10+10 - PVB_DE_1kN-m_10+10_1000

04.03.2020
Seite: 3

Face loads:

- constant distributed:

Package	pressure
	N/mm ²
1	0.00000e+00

Calculation approaches:

small deflections, linear
static calculation

Characteristics of the finite element mesh:

Element size : 20.0 mm
Number of elements : 2500
Number of nodes : 10201 (per package)
Number of unknown : 90900

Calculation results:

Minimum and maximum displacements w:

Package	- Position -		Displacement
	x	y	
	mm	mm	mm
1	0.00	10.00	-0.00 (min)
	500.00	1000.00	27.76 (max)

Maximum principal stress:

Package	Layer	x	y	σ	σ (max)
		mm	mm	N/mm ²	N/mm ²
1	3 (top)	497.75	997.75	1.53	32.07
	(bottom)	497.75	2.25	32.07	
1	1 (top)	502.25	997.75	1.53	32.07
	(bottom)	497.75	2.25	32.07	

Springs:

Package	Layer	u	v	w	φ	θ	Fx	Fy	Fz	M _φ	M _θ
	(x / y)	mm	mm	mm	rad	rad	N	N	N	Nmm	Nmm

Dieser Ausdruck wurde durch das Programm SJ MEPLA erstellt. Copyright 2000-2017 by SJ Software GmbH Aachen.

Projekt: PVB_DE_10+10 - PVB_DE_1kN-m_10+10_1000

04.03.2020
Seite: 4

{	0.00 /	0.00 }										
1	1	0.00	0.00	0.00	0.0000	0.0000	0.00	0.00	0.00	0.00	0.00	0.00
{	1000.00 /	0.00 }										
1	1	0.00	0.00	0.00	0.0000	0.0000	0.00	0.00	0.00	0.00	0.00	0.00

Dieser Ausdruck wurde durch das Programm SJ MEPLA erstellt. Copyright 2000-2017 by SJ Software GmbH Aachen.

Projekt: PVB_DE_10+10 - PVB-DE_1kN-m^2_10+10_1000

04.03.2020
Seite: 1

SJ MEPLA Calculation protocol:

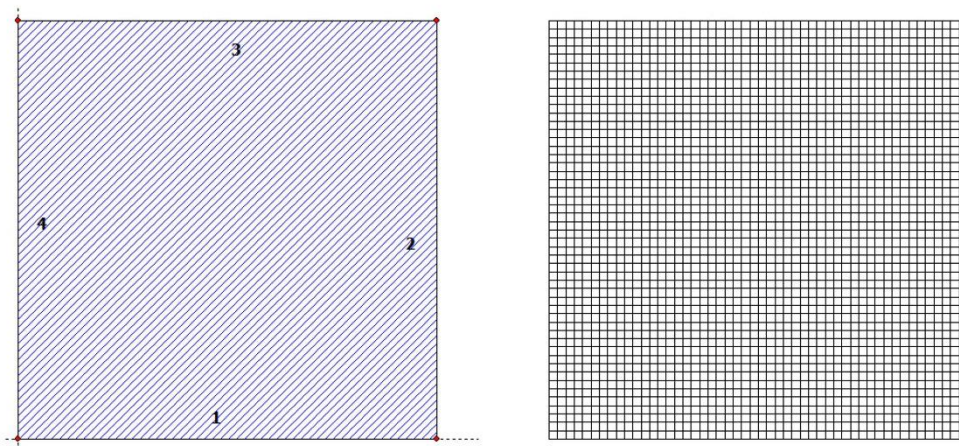

Geometry:

Edge	Borderpoint mm	mm	Arccenter mm	mm	Direction of rotation +/-
1	0.00	0.00			
2	1000.00	0.00			

Dieser Ausdruck wurde durch das Programm SJ MEPLA erstellt. Copyright 2000-2017 by SJ Software GmbH Aachen.

Projekt: PVB_DE_10+10 - PVB-DE_1kN-m*2_10+10_1000

04.03.2020

Seite: 2

3	1000.00	1000.00
4	0.00	1000.00

Supports:

Edge supports:

Edge	Type of supports
1	W, u, v, φ , θ : fixed (all d.o.f supported and clamped)

Spring supports:

Package	Layer	x	y	z	C x	C y	C z	C φ	C θ
		mm	mm	mm	N/mm	N/mm	N/mm	Nmm	Nmm
1	1	0.0	0.0	0.0	1.000e+00	1.000e+00	0.000e+00	0.00e+00	0.00e+00
1	1	1000.0	0.0	0.0	0.000e+00	1.000e+00	0.000e+00	0.00e+00	0.00e+00

Layers:

Layer order:

Package	Layer	Description
1	3	ESG
1	2	PVB Langzeitbelastung
1	1	ESG

Mechanical properties:

Package	Layer	E-mod.	v	Thickness	Density	α	ΔT
		N/mm ²		mm	kg/m ³	1/K	K
1	3	70000.00	0.23	10.00	2550.00	1.0000e-05	0.00
1	2	0.00	0.50	0.76	1070.00	8.0000e-05	0.00
1	1	70000.00	0.23	10.00	2550.00	1.0000e-05	0.00

Loads:

Face loads:

- constant distributed:
Package pressure
N/mm ²

Dieser Ausdruck wurde durch das Programm SJ MEPLA erstellt. Copyright 2000-2017 by SJ Software GmbH Aachen.

Projekt: PVB_DE_10+10 - PVB-DE_1kN-m*2_10+10_1000

04.03.2020

Seite: 3

1	1.00000e-03
---	-------------

Calculation approaches:

small deflections, linear
static calculation

Characteristics of the finite element mesh:

Element size	: 20.0 mm
Number of elements	: 2500
Number of nodes	: 10201 (per package)
Number of unknown	: 90900

Calculation results:

Minimum and maximum displacements w:

Package	- Position -		Displacement w
	x	y	
	mm	mm	mm
1	0.00	0.00	0.00 (min)
	500.00	1000.00	10.35 (max)

Maximum principal stress:

Package	Layer	x	y	σ	σ (max)
		mm	mm	N/mm ²	N/mm ²
1	3 (top)	497.75	997.75	0.35	15.59
	(bottom)	382.25	2.25	15.59	
1	1 (top)	502.25	997.75	0.35	15.59
	(bottom)	382.25	2.25	15.59	

Springs:

Package	Layer	u	v	w	φ	θ	Fx	Fy	Fz	M φ	M θ	
		(x / y)	mm	mm	mm	rad	rad	N	N	N	Nmm	Nmm
		(0.00 / 0.00)										
1	1	0.00	0.00	0.00	0.0000	0.0000	0.00	0.00	0.00	0.00	0.00	
		(1000.00 / 0.00)										
1	1	0.00	0.00	0.00	0.0000	0.0000	0.00	0.00	0.00	0.00	0.00	

Dieser Ausdruck wurde durch das Programm SJ MEPLA erstellt. Copyright 2000-2017 by SJ Software GmbH Aachen.

Informazioni generali e risultati calcolo numerico con Sofistik E200-LCA e LCB

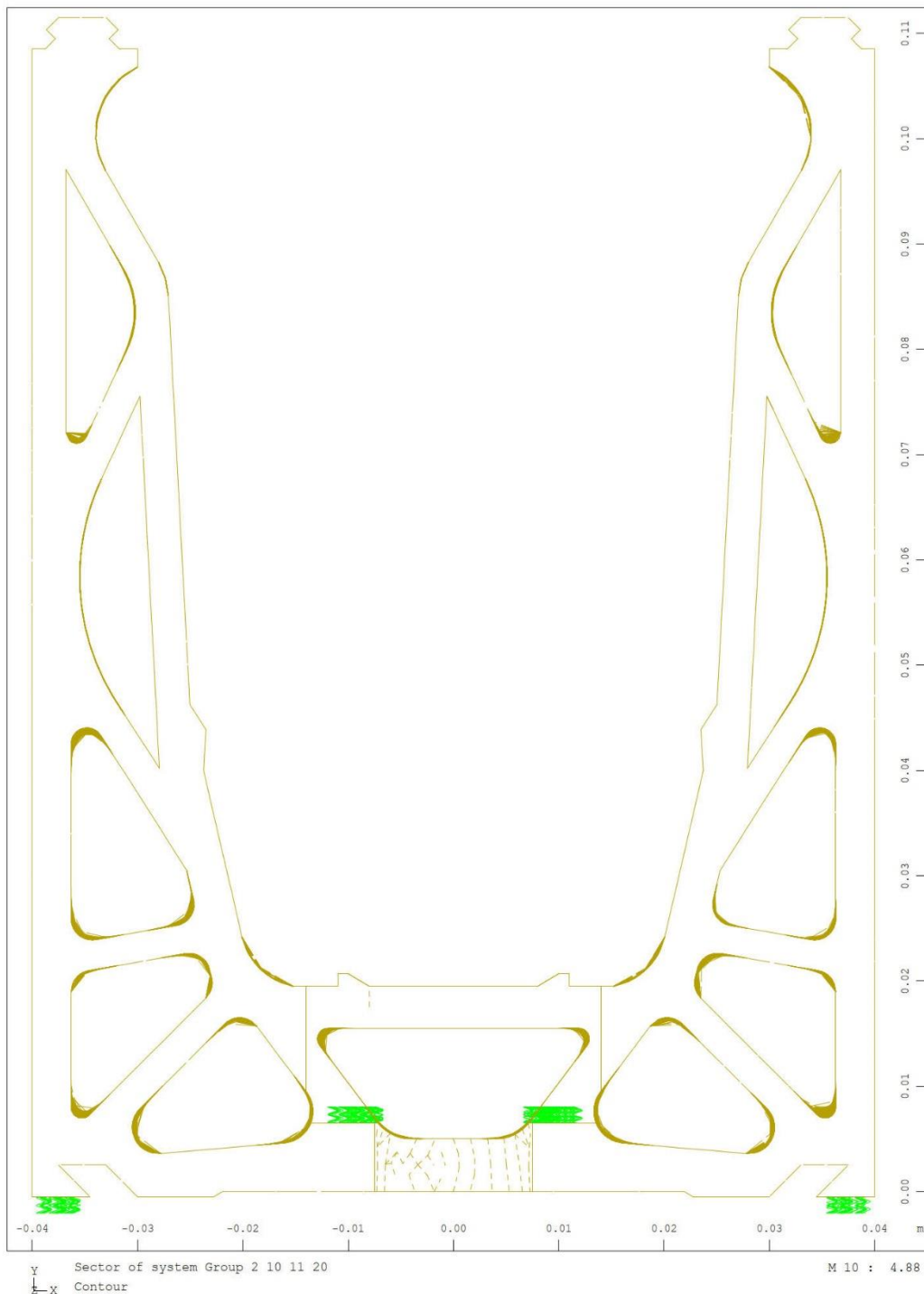

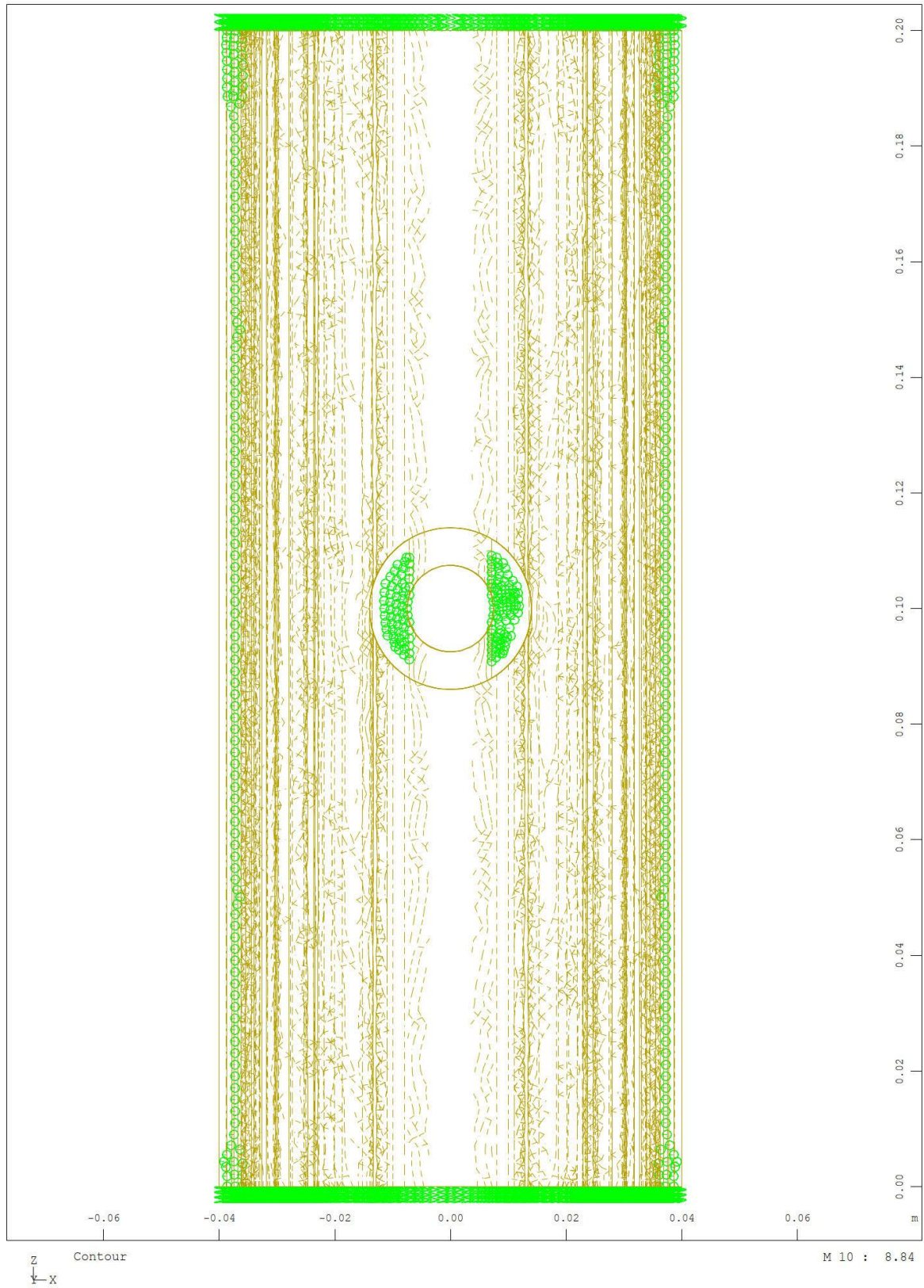

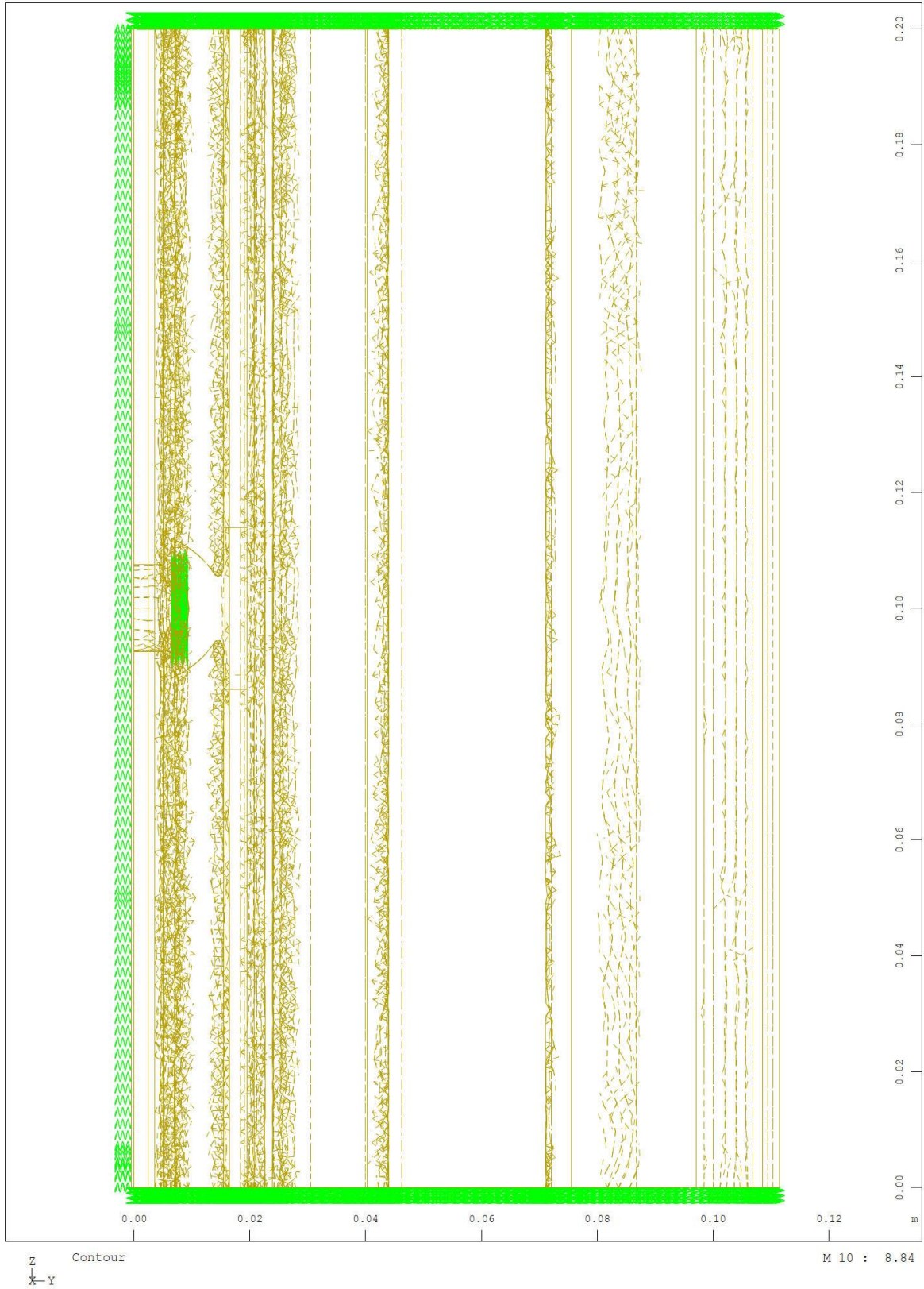

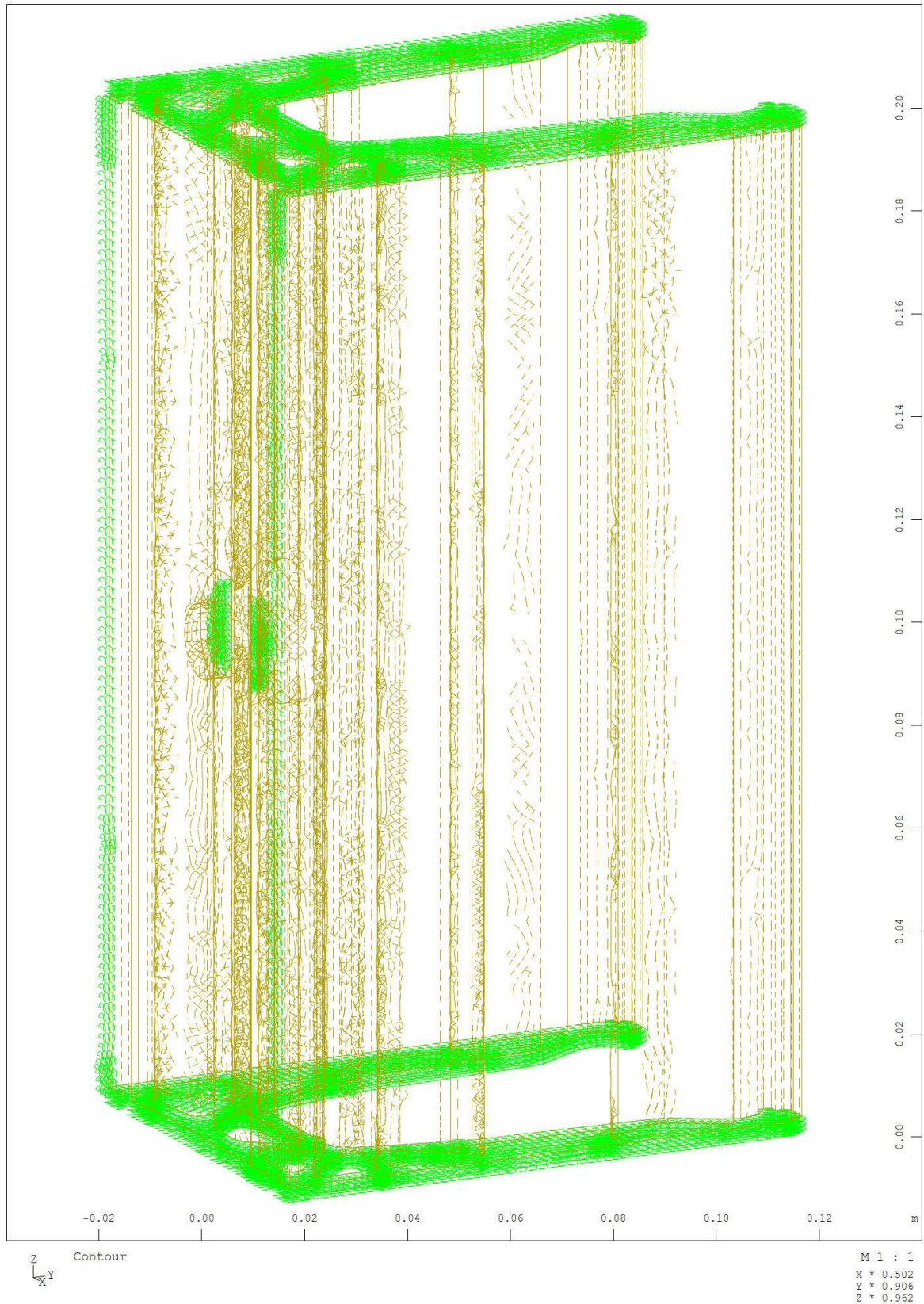

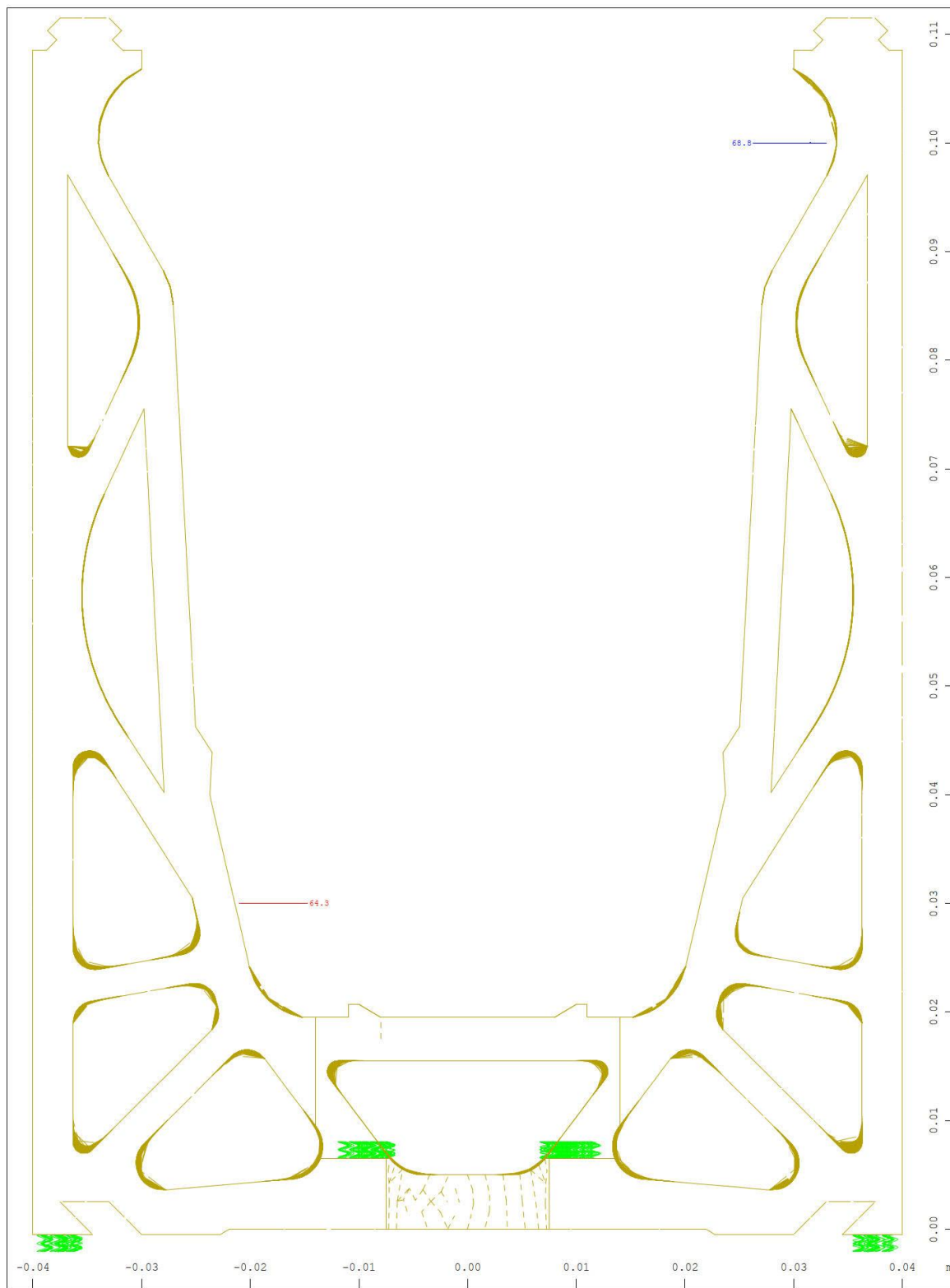

Y Sector of system Group 2 10 11 20 M 10 : 4.88
 X All loads, nonlinear Loadcase 10 ULS , (1 cm 3D = unit) Free line load (force) in
 global X (Unit=50.0 kN/m (Min=-64.3) (Max=68.8))

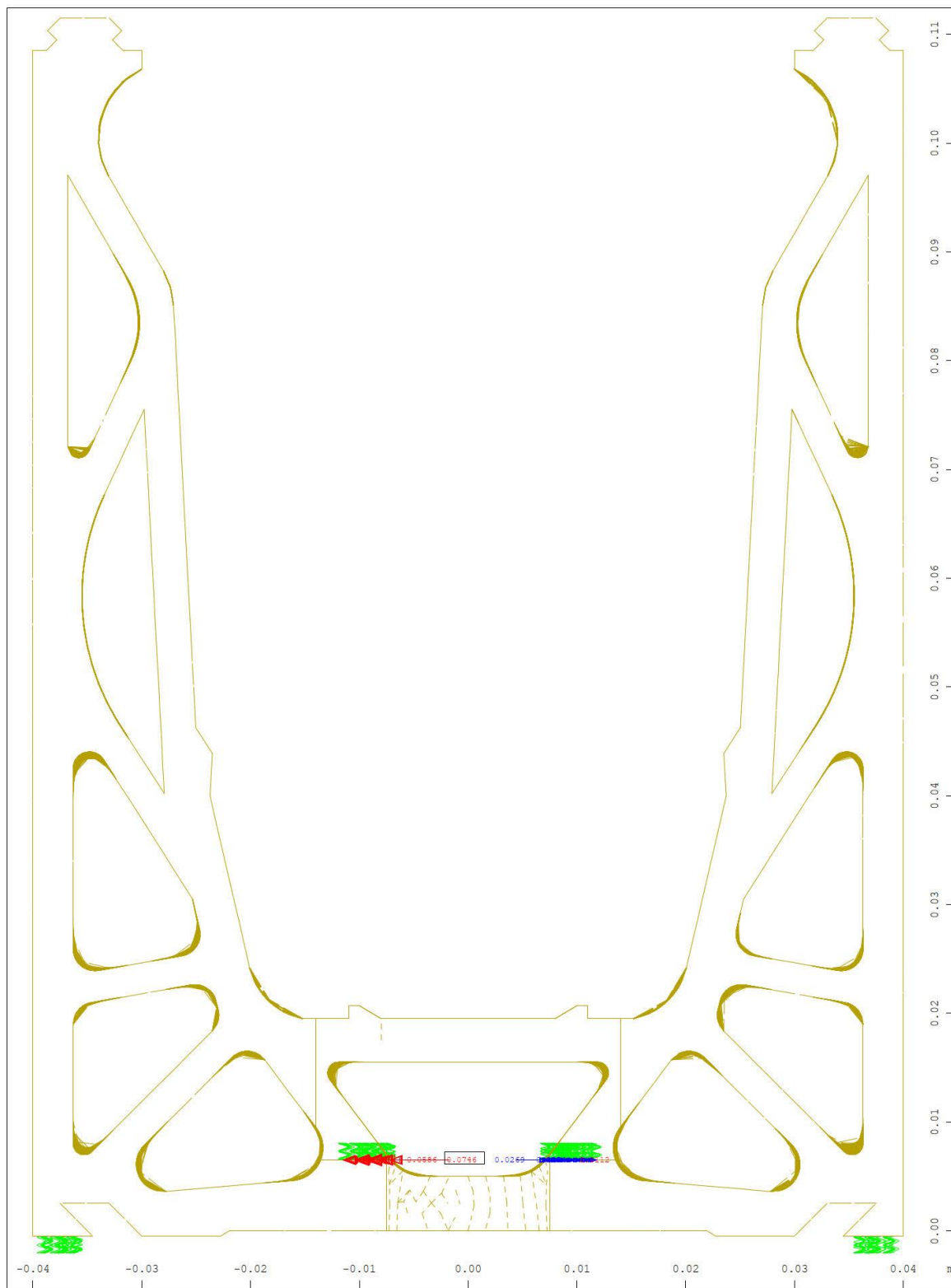

Y Sector of system Group 2 10 11 20 M 10 : 4.88
 X Supporting springs , Spring force in global X, nonlinear Loadcase 10 ULS , 1 cm 3D =
 0.0500 kN (Min=-0.0746) (Max=0.0287) (total: -0.900)

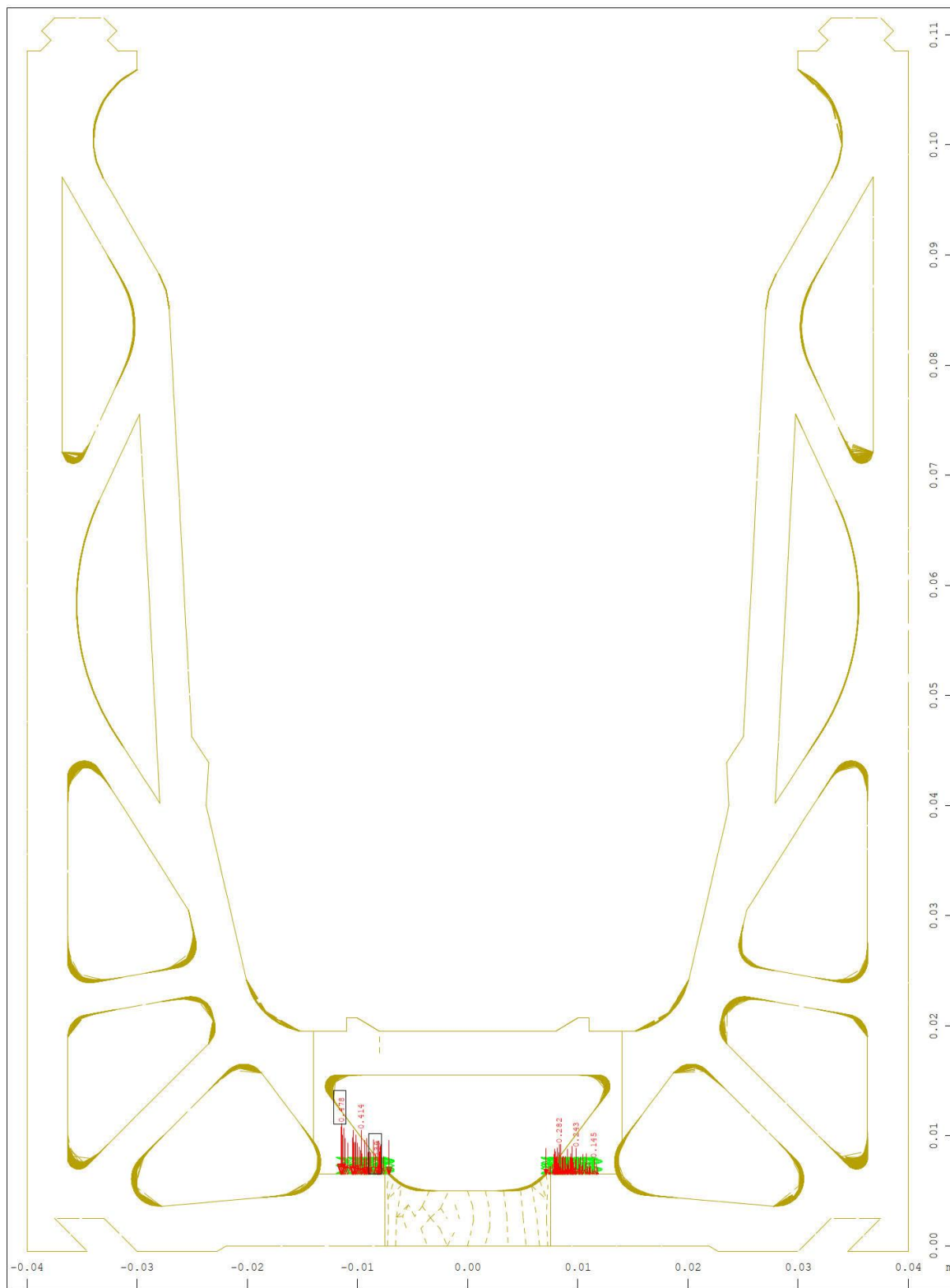

Y Sector of system Group 2 20
 X Supporting springs , Spring force in global Y, nonlinear Loadcase 10 ULS , 1 cm 3D =
 0.500 kN (Min=-0.478) (Max=0) (total: -25.5)

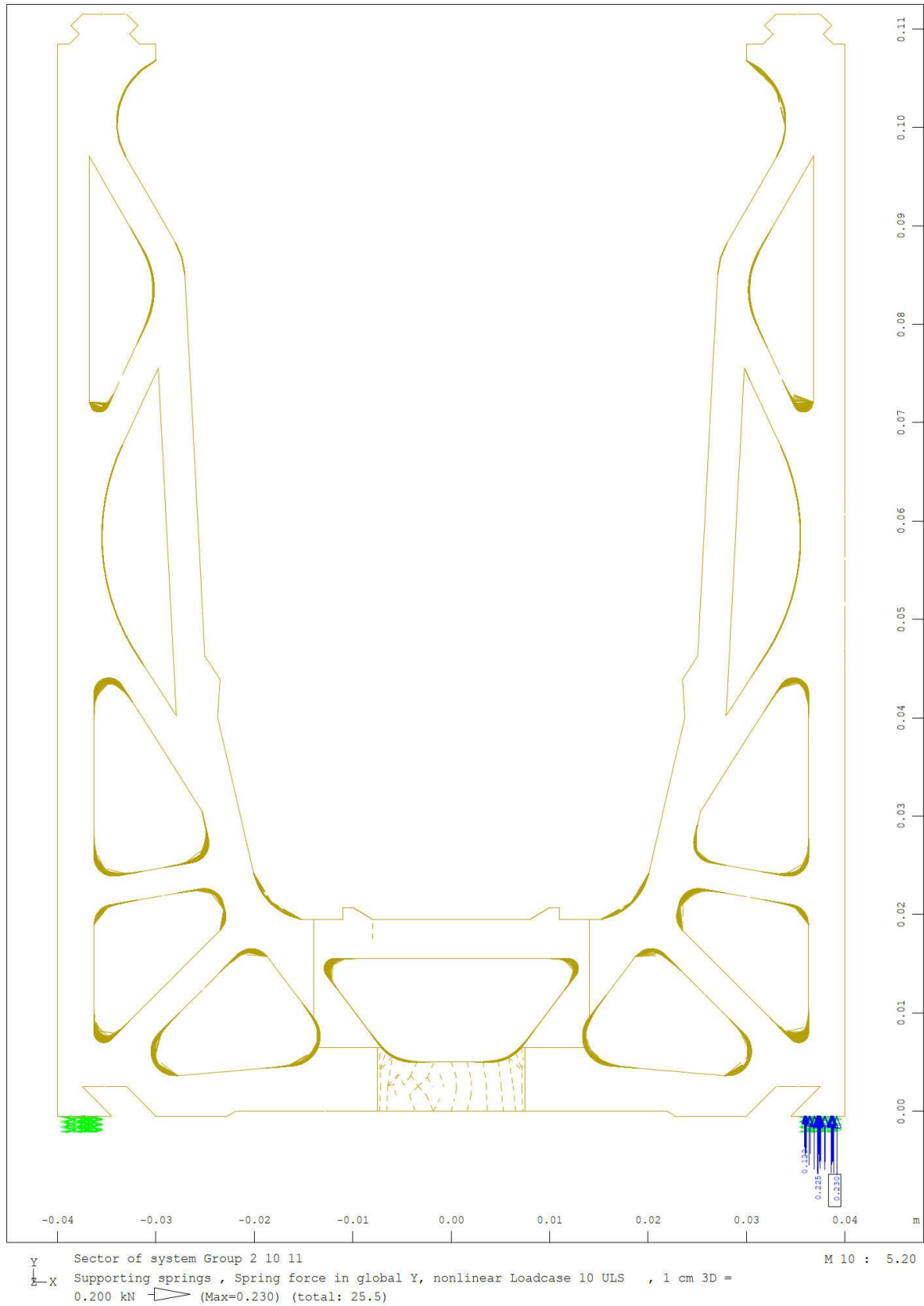

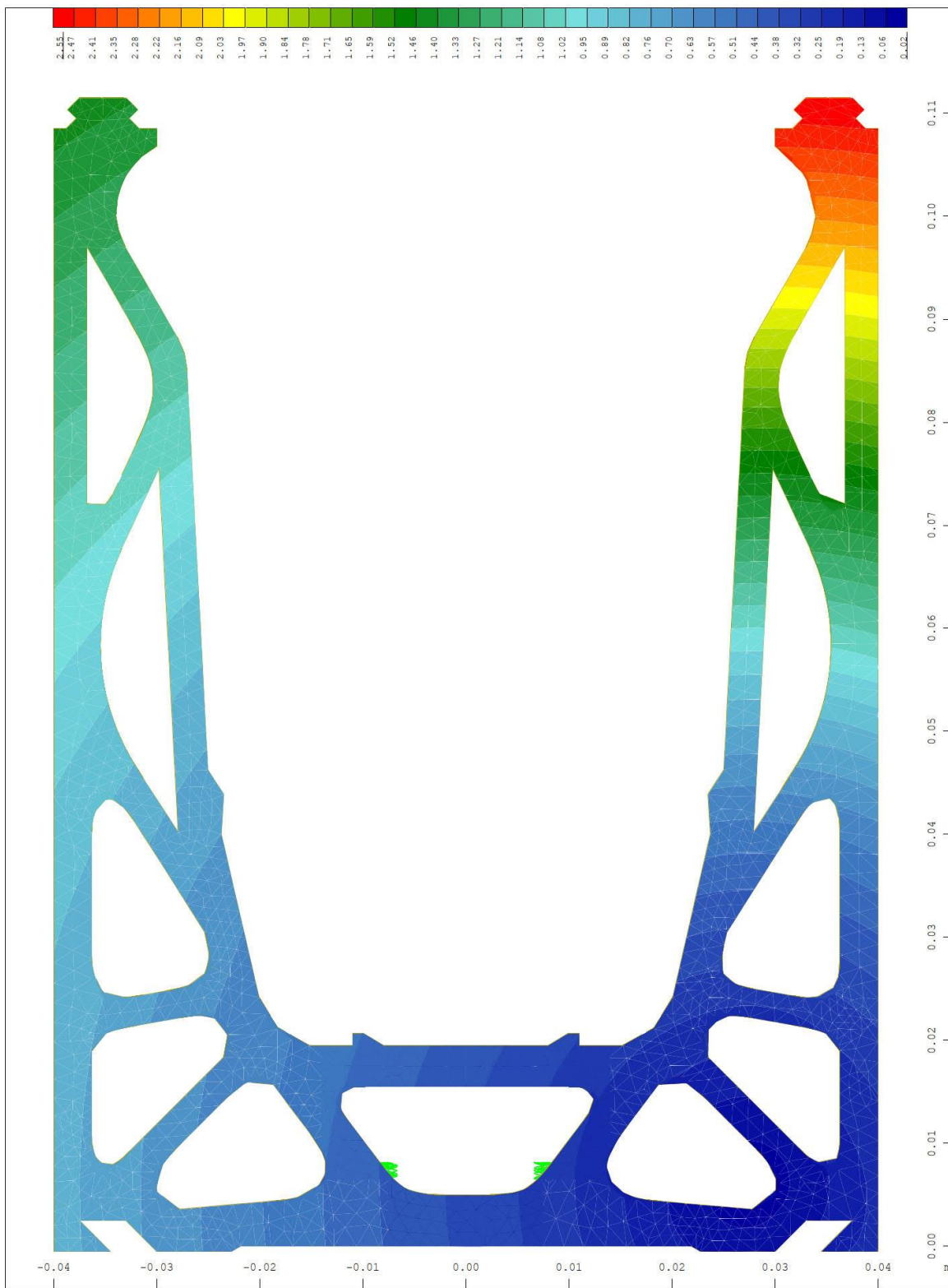

Y Sector of system Group 2 20 M 10 : 5.15
 Z-X Nodal displacement vector in Node, nonlinear Loadcase 10 ULS , from 0.0166 to 2.55
 step 0.0635 mm

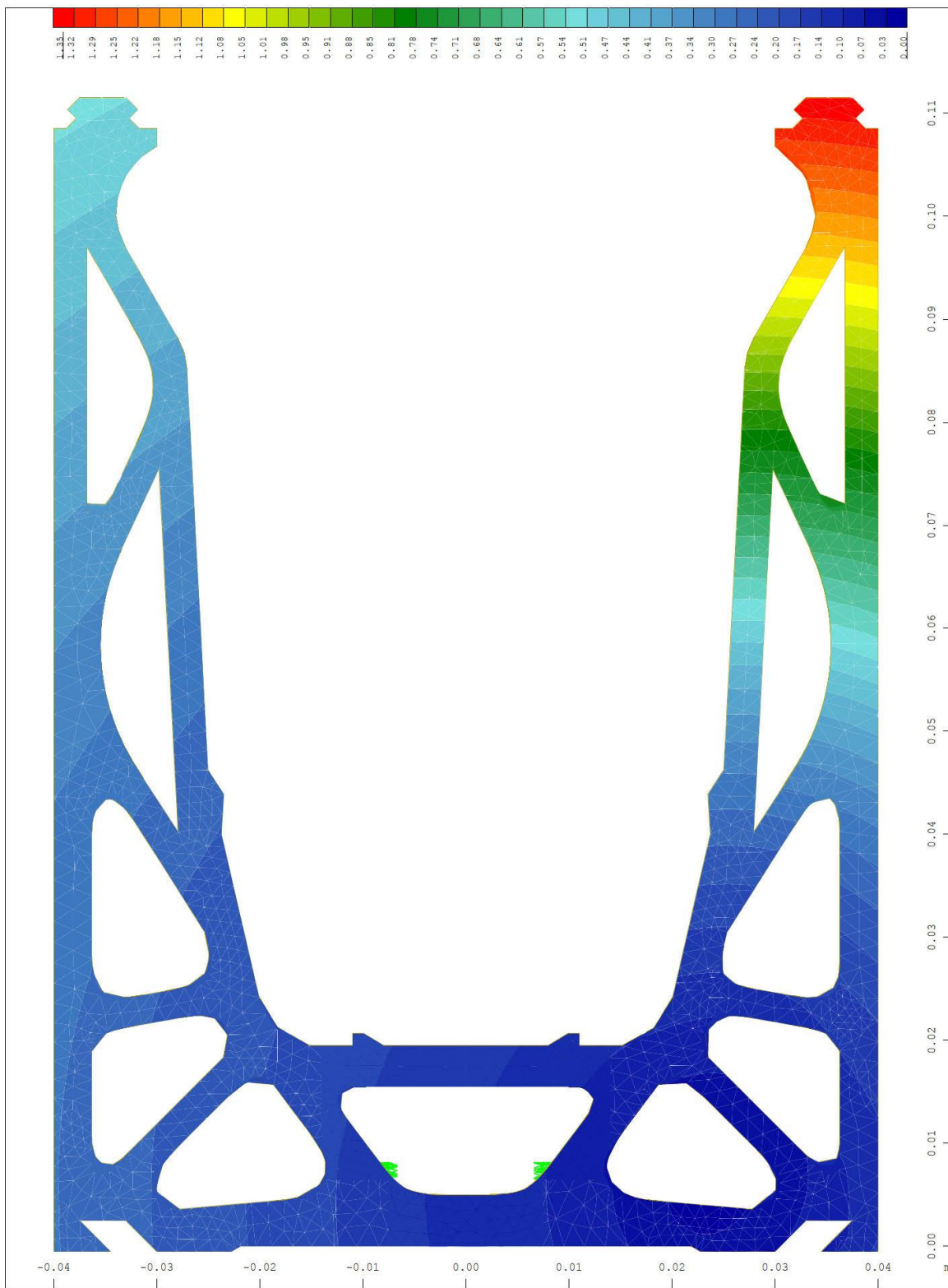

Y Sector of system Group 2 20 M 10 : 5.15
 X Nodal displacement vector in Node, nonlinear Loadcase 20 SLS , from 0.0021 to 1.35
 step 0.0338 mm

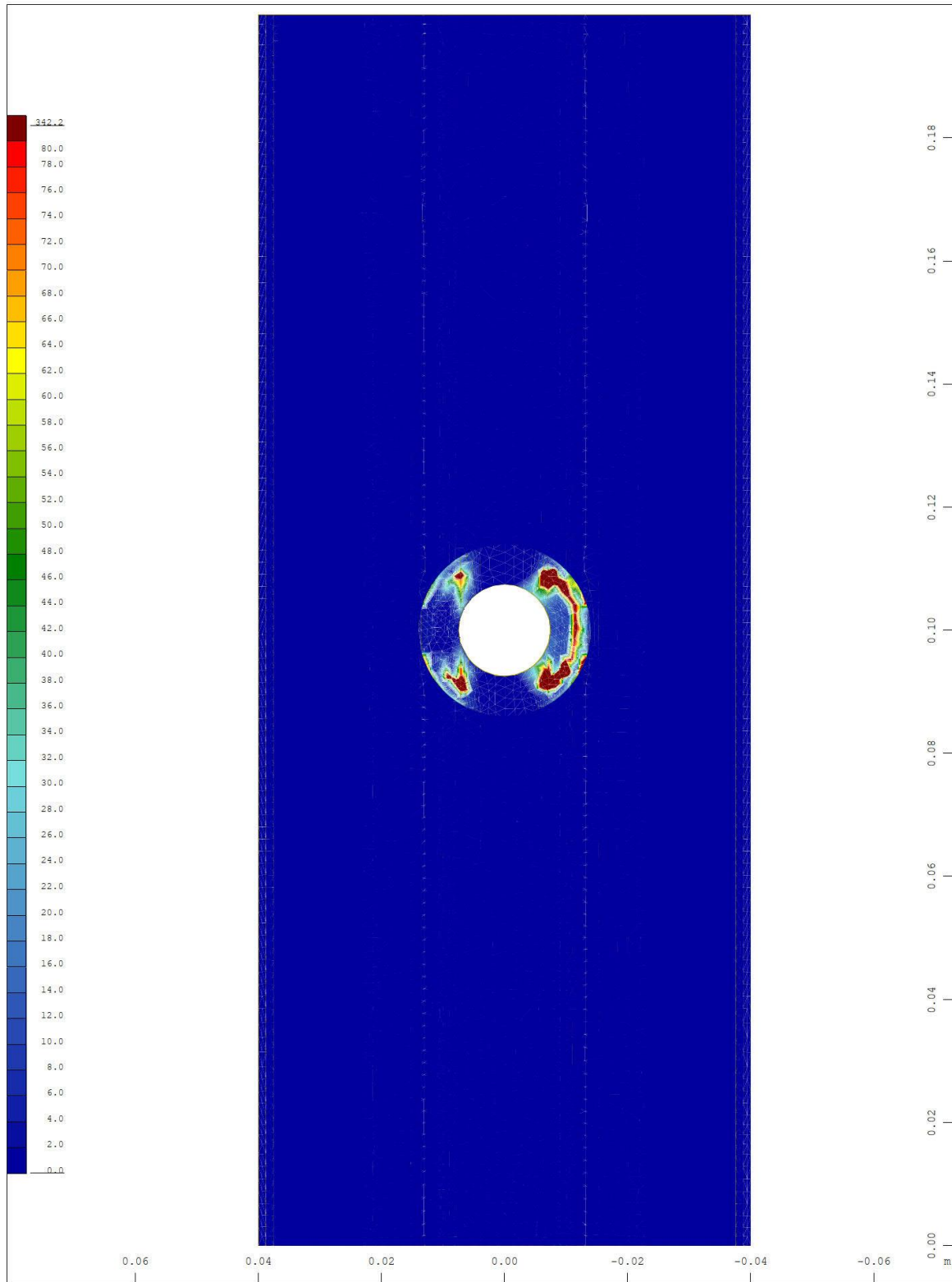

Sector of system Group 2
 Plastic deviatoric strain \leftrightarrow , nonlinear Loadcase 10 ULS, Material law Mat.type 17 ,
 BRIC Gauss points in Node o/oo, from 0 to 80.0 step 2.00
 M 10 : 8.60

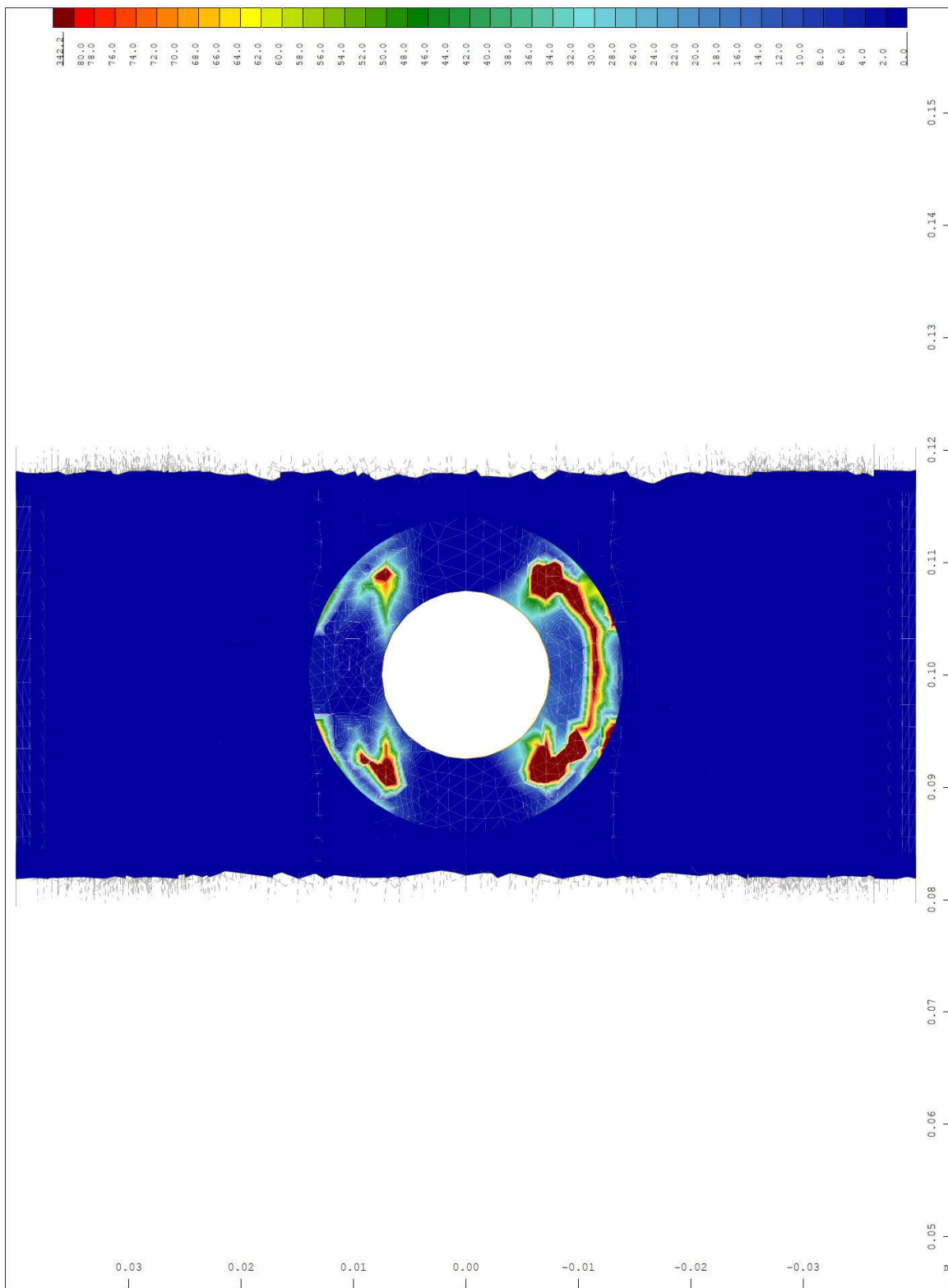

Sector of system Group 2
 Plastic deviatoric strain \leftrightarrow , nonlinear Loadcase 10 ULS, Material law Mat.type 17
 BRIC Gauss points in Node o/oo, from 0 to 80.0 step 2.00
 M 10 : 4.72

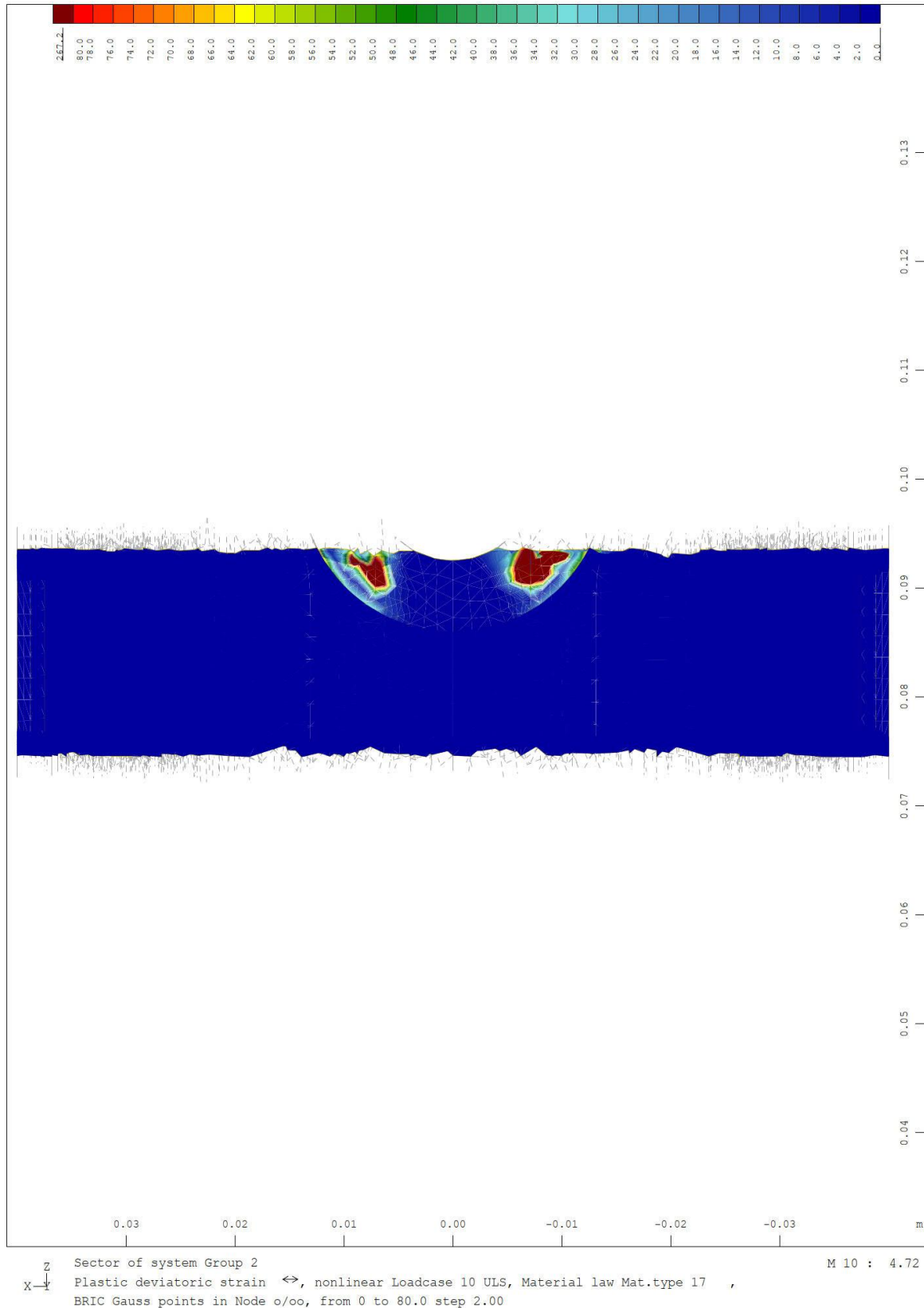

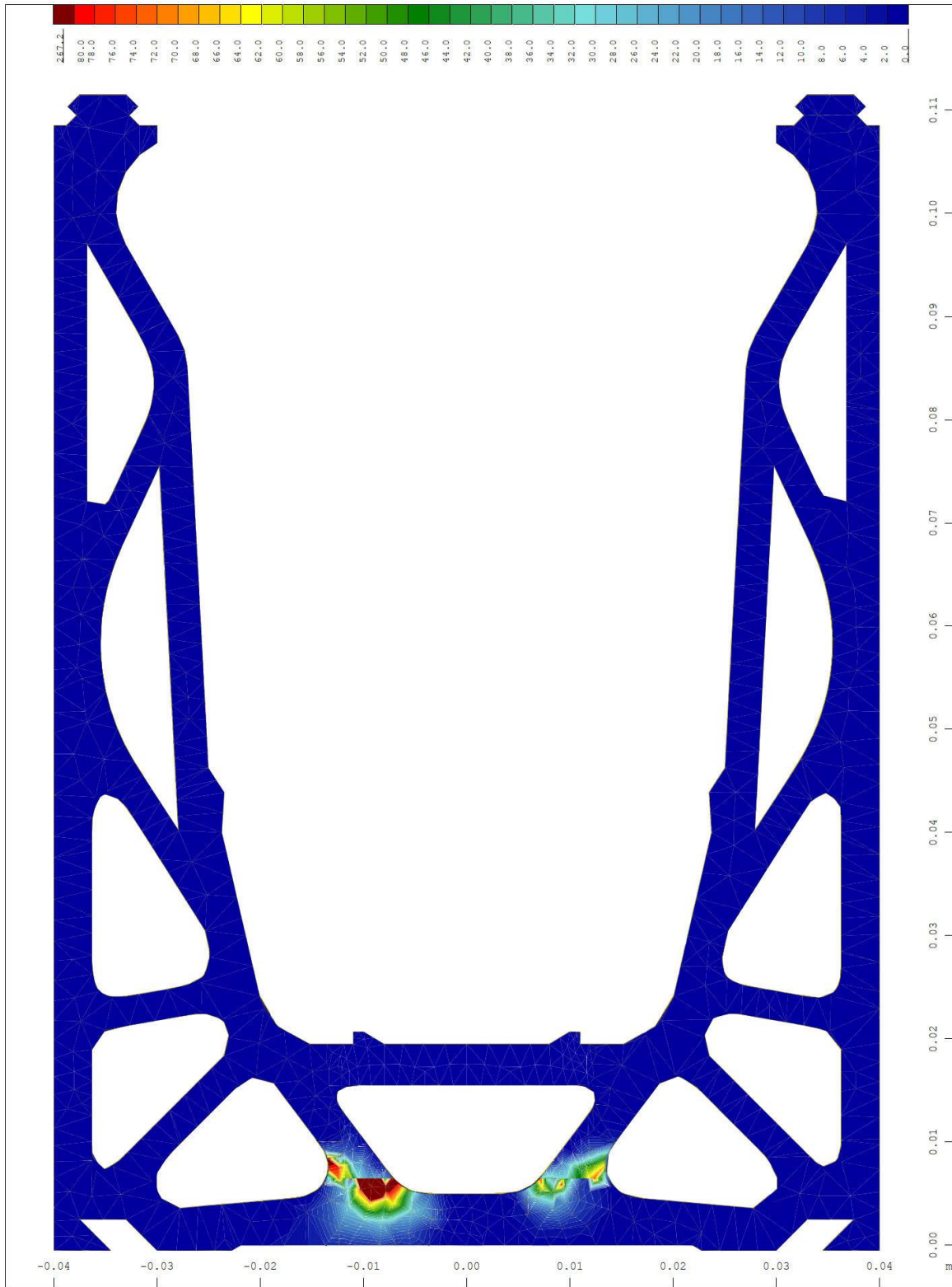

Y Sector of system Group 2 M 10 : 5.15
 X Plastic deviatoric strain \leftrightarrow , nonlinear Loadcase 10 ULS, Material law Mat.type 17
 BRIC Gauss points in Node o/oo, from 0 to 80.0 step 2.00

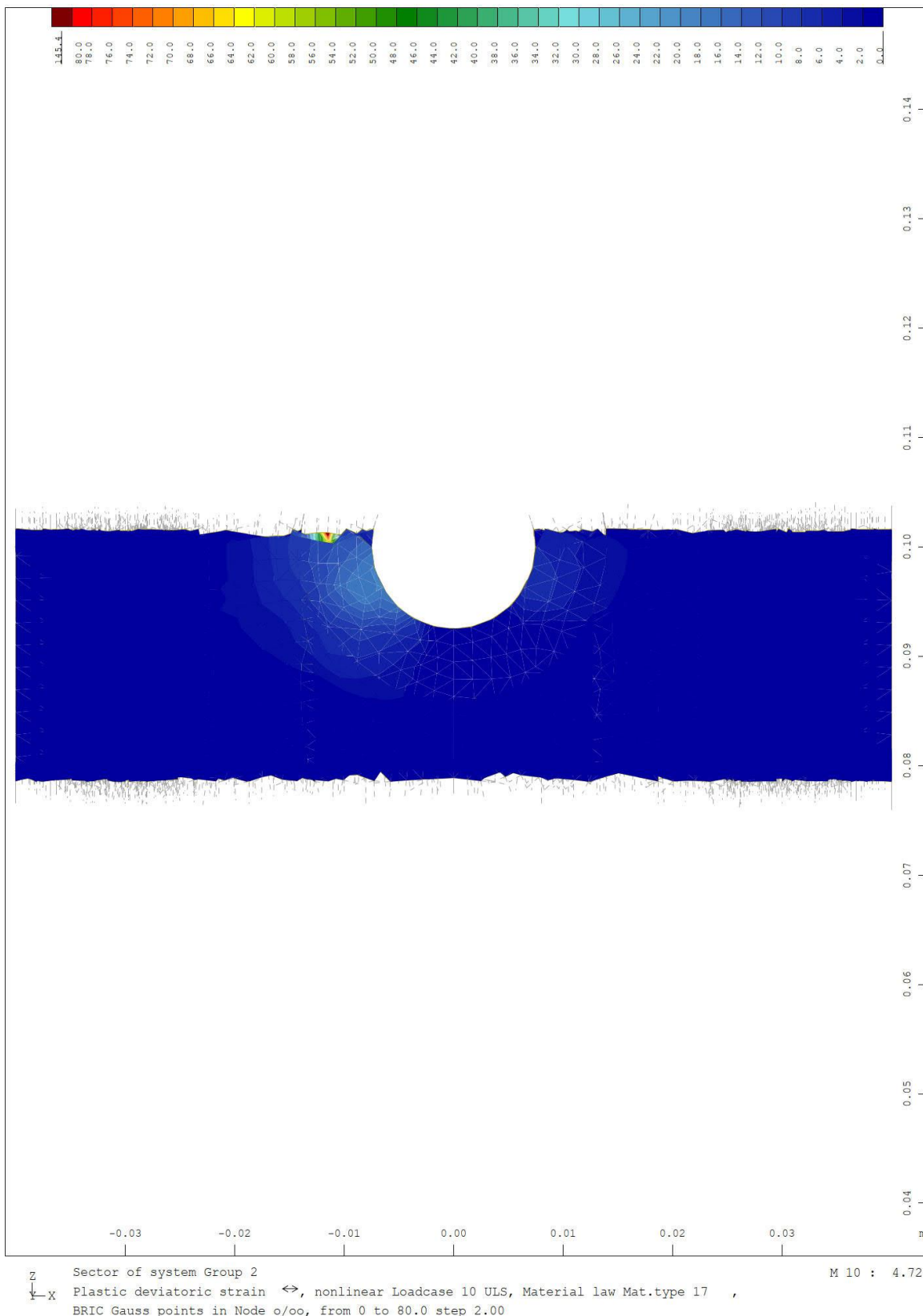

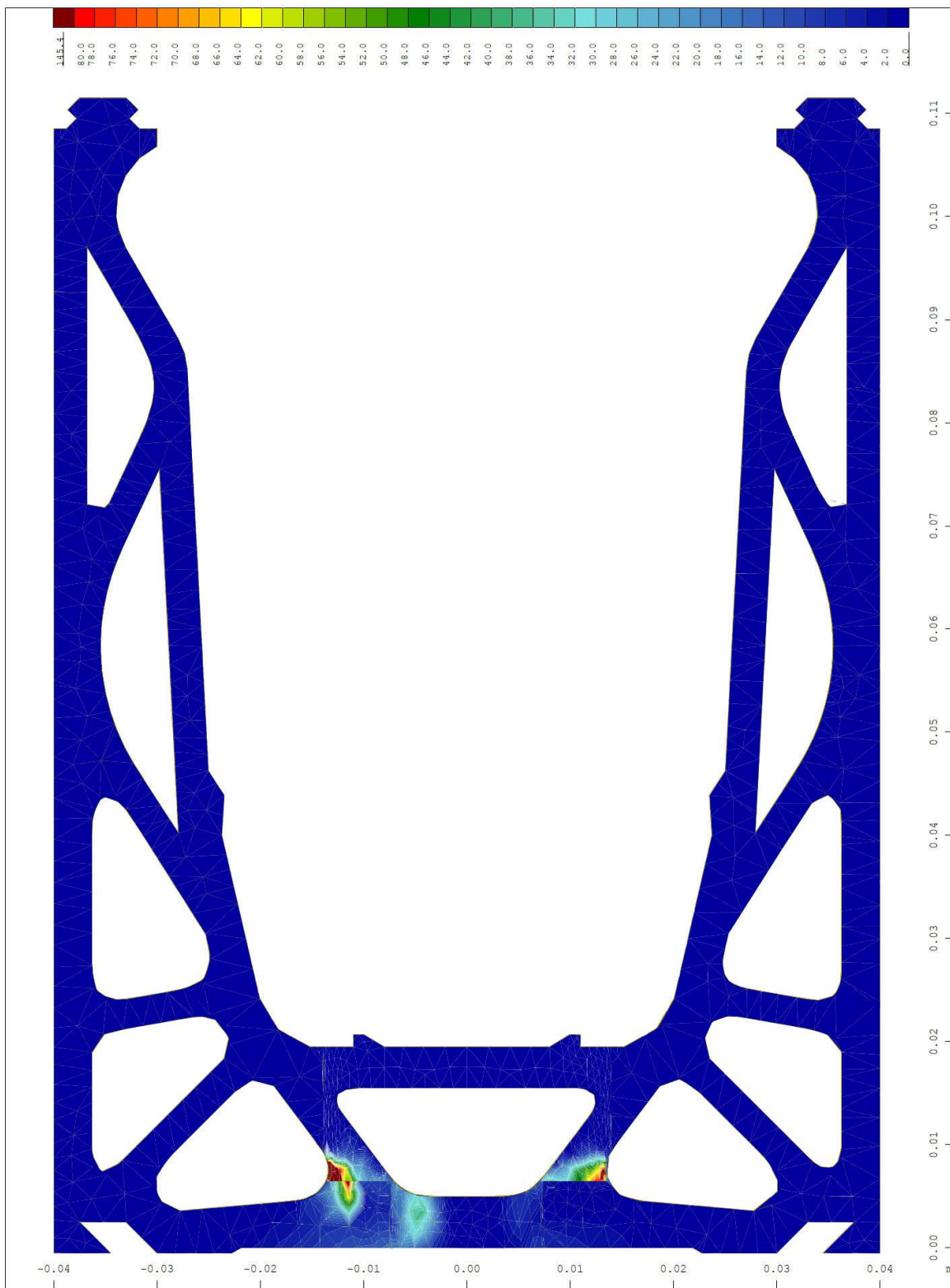

Y Sector of system Group 2 M 10 : 5.15
 X Plastic deviatoric strain \leftrightarrow , nonlinear Loadcase 10 ULS, Material law Mat.type 17 ,
 BRIC Gauss points in Node o/oo, from 0 to 80.0 step 2.00

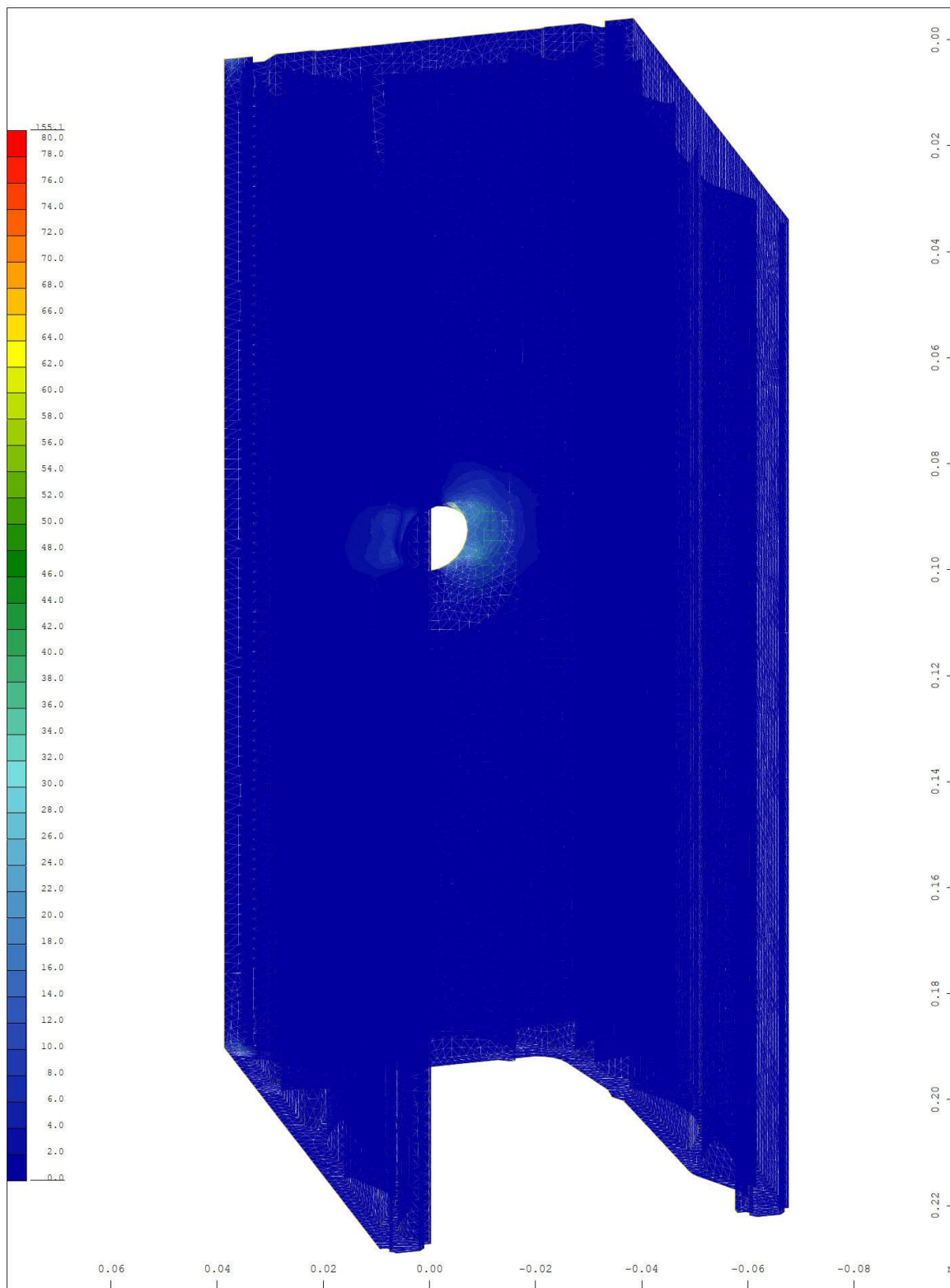

Sector of system Group 2 20
 Plastic deviatoric strain \leftrightarrow , nonlinear Loadcase 10 ULS, Material law Mat.type 17 , BRIC
 Gauss points in Node o/oo, from 0 to 80.0 step 2.00

M 1 : 1
 X * 0.968
 Y * 0.440
 Z * 0.932

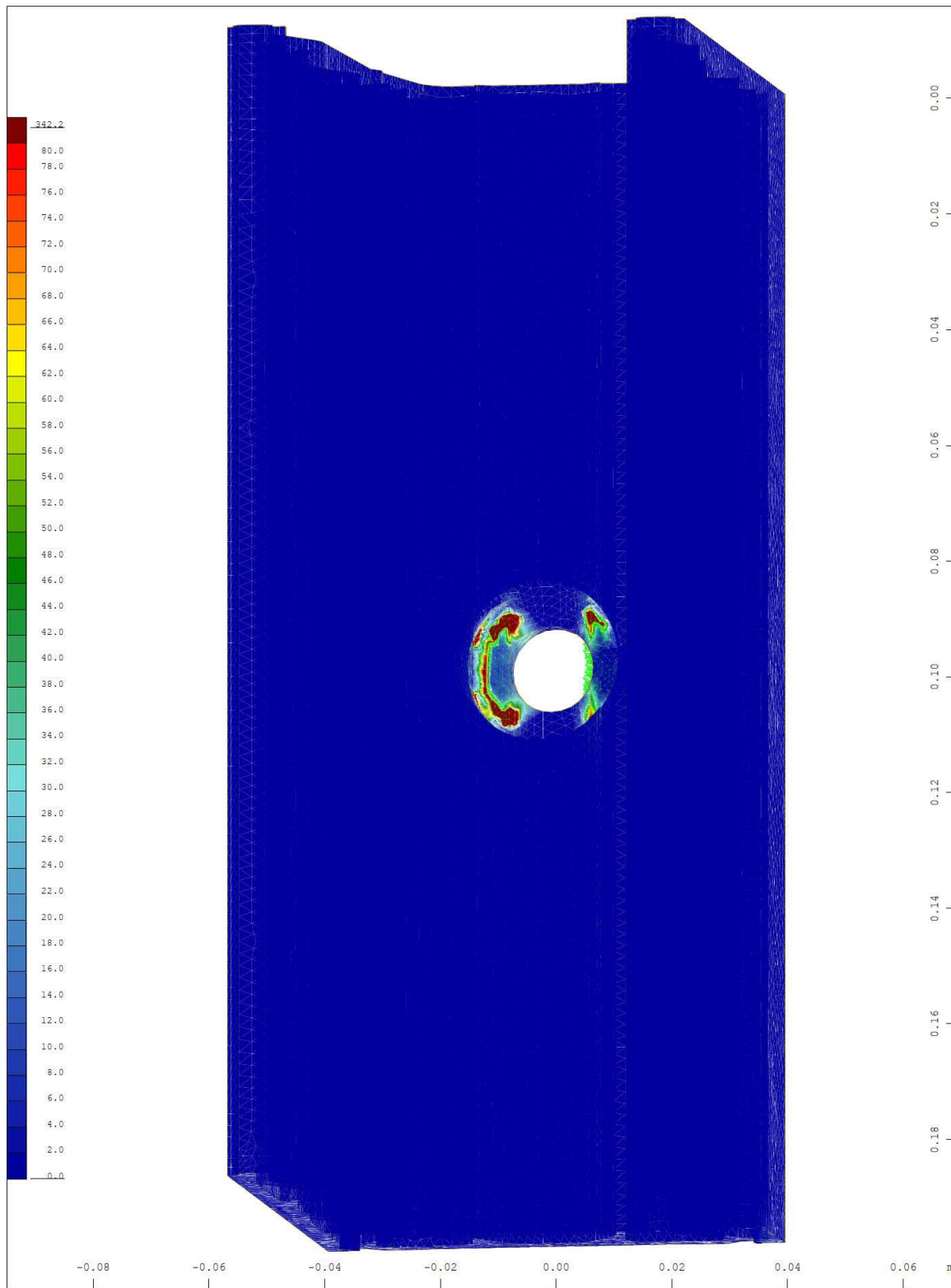

X
Y
Z

Sector of system Group 2 20
 Plastic deviatoric strain \leftrightarrow , nonlinear Loadcase 10 ULS, Material law Mat.type 17 ,
 BRIC Gauss points in Node o/oo, from 0 to 80.0 step 2.00

M 10 : 9.18
 X * 0.987
 Y * 0.200
 Z * 0.993

Nota: localmente nella zona della introduzione della forza di appoggio nelle molle gli elementi finiti fanno vedere delle plasticizzazioni superiori alle 80%o ammissibili. Questo è causato sia da problemi numerici dovuto alla introduzione di forze molto elevate in pochi nodi che dalla legge di materiale molto conservativa con il plateau di snervamento orizzontale.

Per di più gli allungamenti plastici locali sono causati soprattutto da tensioni tridimensionali di compressione e non da tensioni normali di trazione dovuto a flessione. Per queste compressioni locali il materiale di modello non è adatto, analiticamente per zone a compressione sotto bulloni pressioni locali molto più alti sono permessi.

Perciò il punto di valutazione della resistenza del profilo corrisponde alla situazione quando una parte decisiva della sezione è completamente snervata.

Da una curva di resistenza del profilo fatta durante la verifica si vede che dopo il punto di valutazione esiste ancora una certa resistenza residua della sezione.

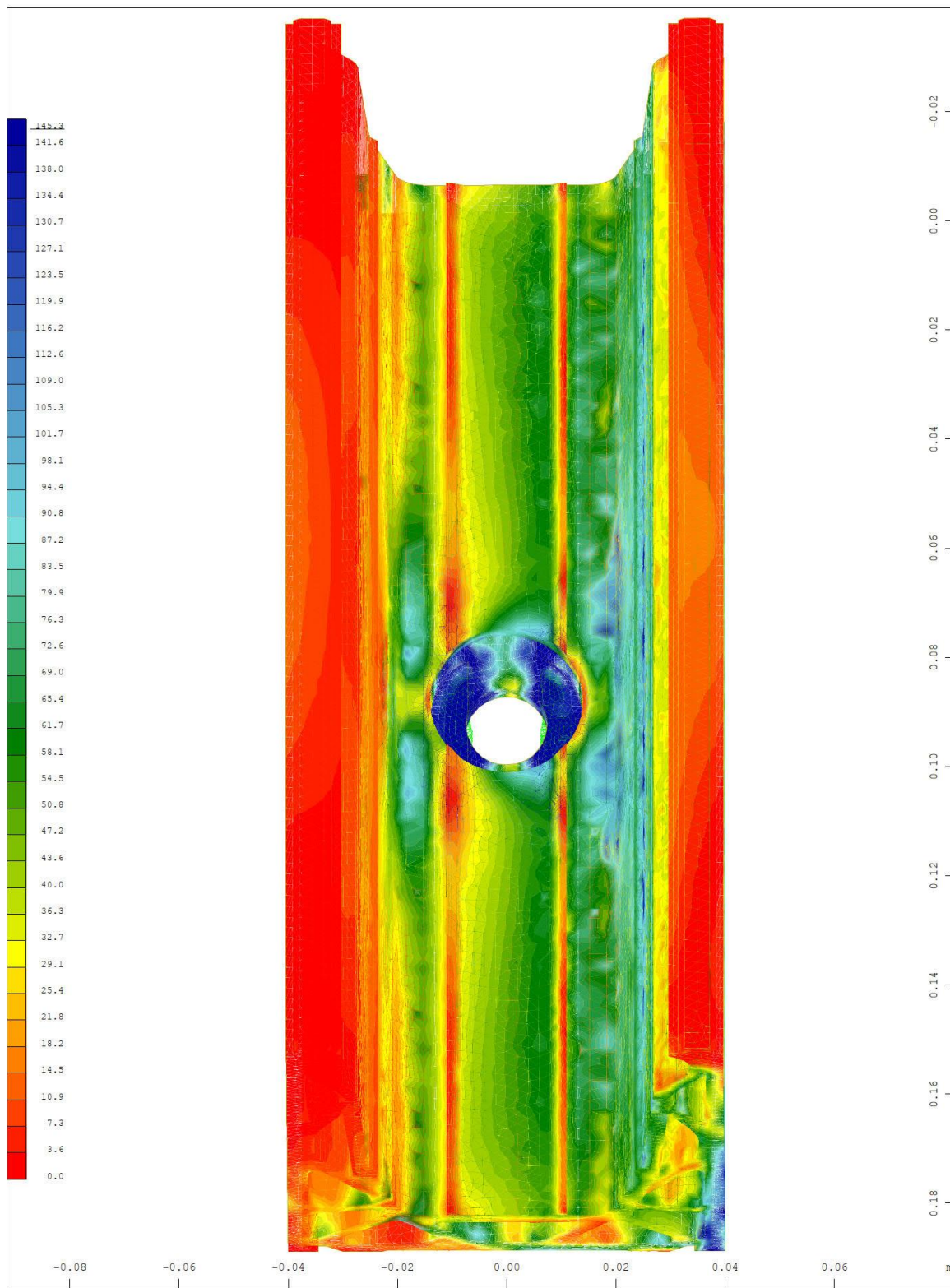

Y
X
Z

Sector of system Group 2 20
v.Mises stress from middle of element \leftrightarrow , nonlinear Loadcase 10 ULS , from 0.0617 to
145.3 step 3.63 MPa

M 10 : 9.71
X * 1.000
Y * 0.332
Z * 0.943

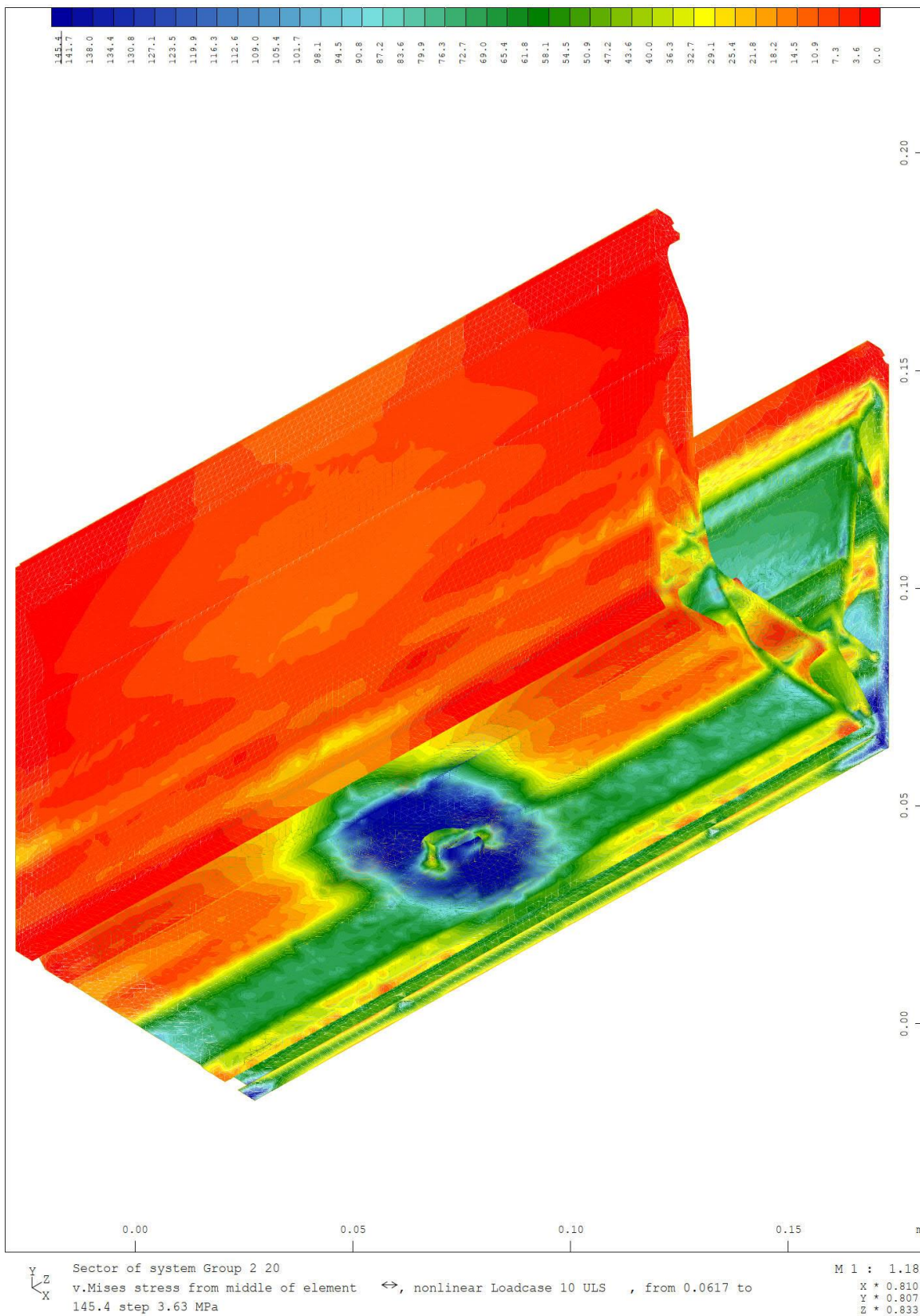

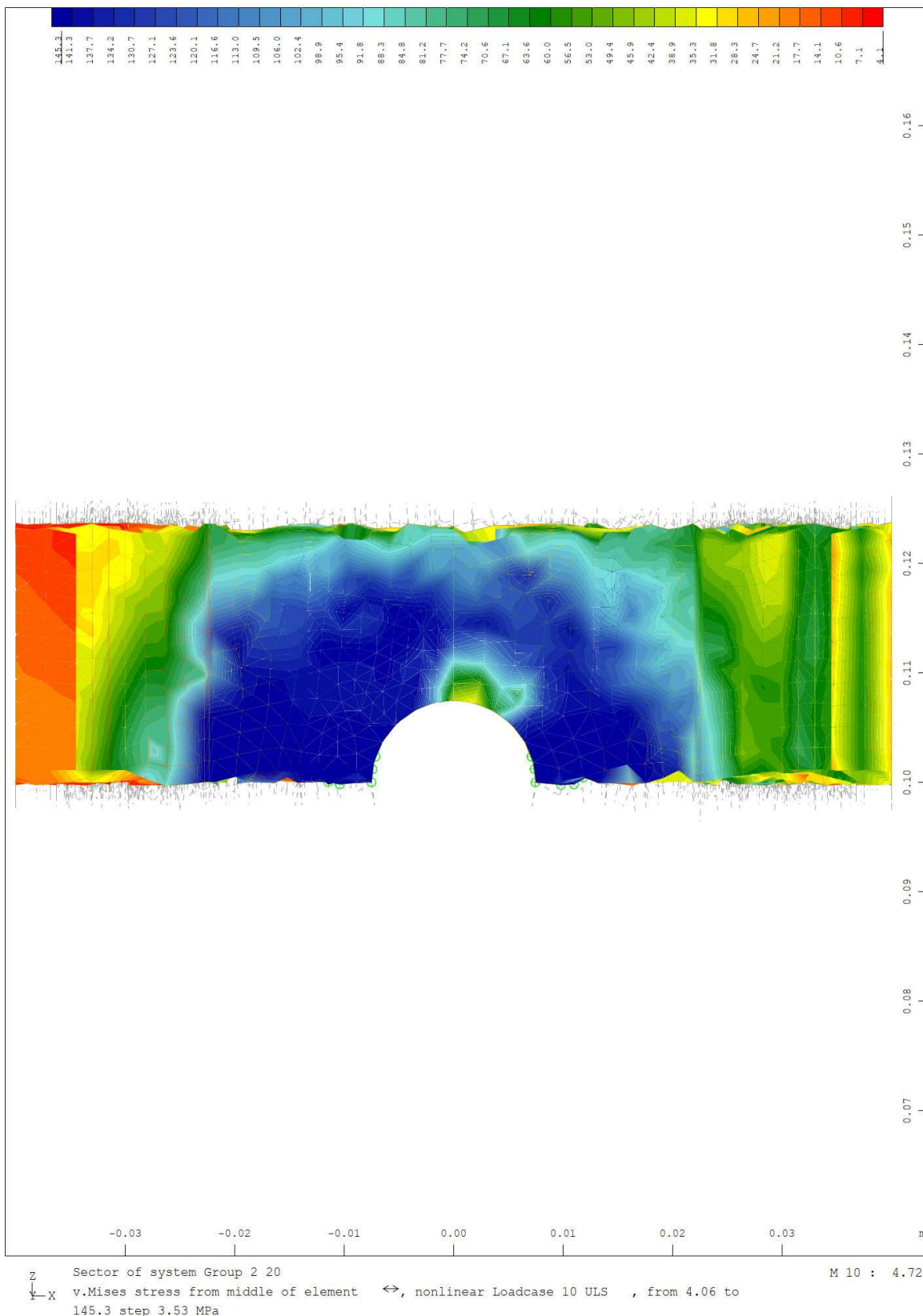

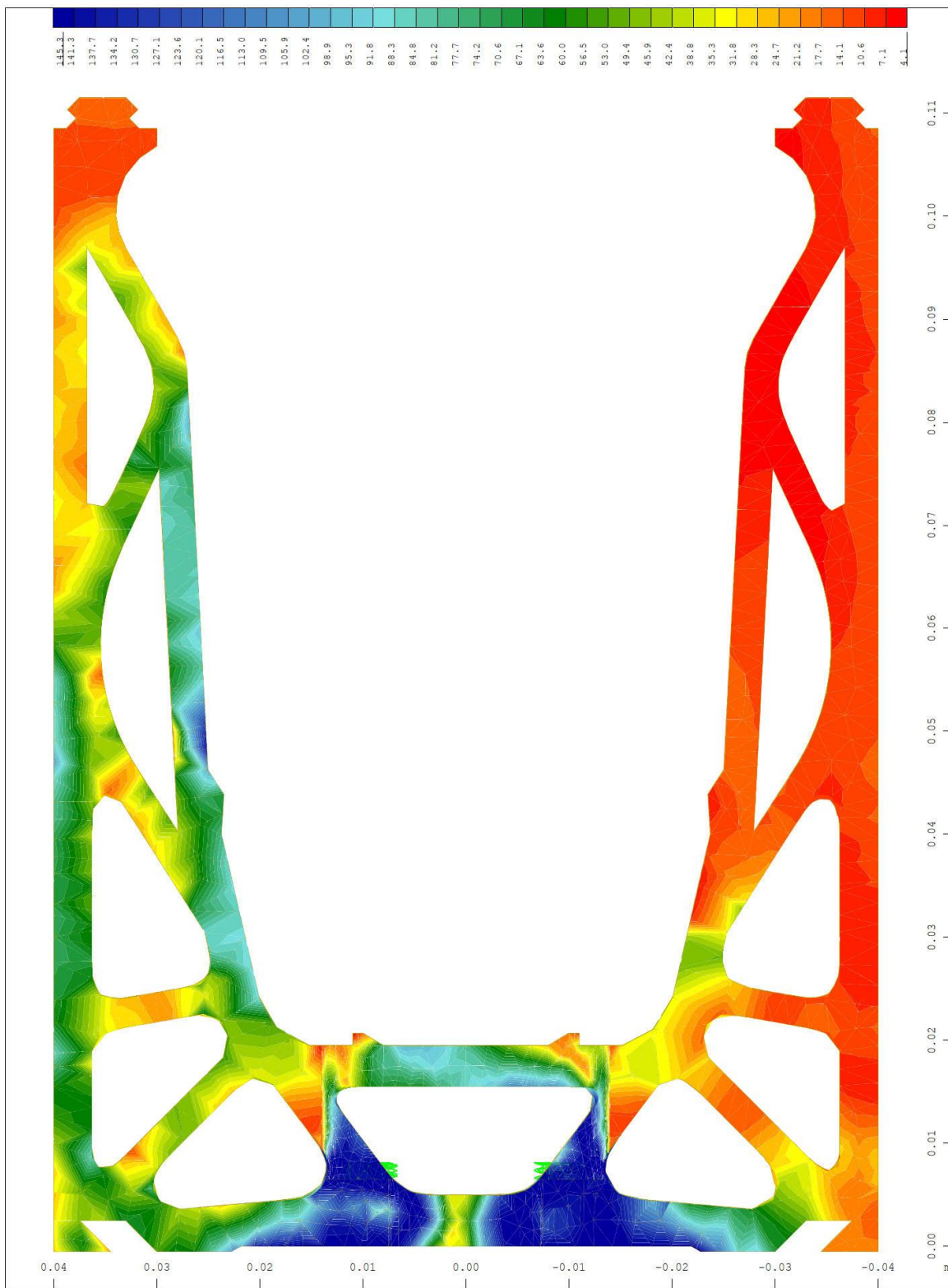

Sector of system Group 2 20
 v.Mises stress from middle of element \leftrightarrow , nonlinear Loadcase 10 ULS , from 4.08 to 145.3 step 3.53 MPa
 M 10 : 5.15