



TEST REPORT No. 343590

Place and date of issue: Bellaria-Igea Marina - Italy, 30/06/2017

Customer: LOGLI MASSIMO S.p.A. unipersonale - Via Chemnitz, 49/51 - Zona Industriale Macrolotto 2 - 59100 PRATO (PO) - Italy

Date test requested: 12/06/2017

Order number and date: 73507, 12/06/2017

Date specimen received: 21/06/2017

Test date: 21/06/2017

Purpose of test: uniform snow load on a shelter

Test site: Istituto Giordano S.p.A. - Via Erbosa, 72 - 47043 Gatteo (FC) - Italy

Specimen origin: sampled and supplied by the Customer

Identification of specimen received: No. 2017/1474/A

Specimen name*

The test specimen is called "LA PENSILINA-SG".

(*) according to that stated by the Customer.

Comp. AV
Revis. MN

This test report consists of 8 sheets.

This document is the English translation of the test report No. 343590 dated 30/06/2017 issued in Italian;
in case of dispute the only valid version is the Italian one. Date of translation: 16/02/2018.

Sheet
1 of 8

Description of specimen*

The test specimen is a shelter consisting of:

- glazing panel comprising 8.8.4 SentryGlas® (1,52) laminated glass, nominal length 2000 mm, nominal projection 1200 mm and nominal thickness 17,52 mm, formed by 2 panes of toughened glass, nominal thickness 8 mm each, with plastic interlayer, overall nominal thickness 1,52 mm;
- aluminium fixing system.

The specimen also has a test frame in which it was installed by the Customer at 10 fixing points using steel nuts and bolts.

Further details of specimen specifications can be seen in the Customer-supplied schematic drawings on the next page.



Specimen photo

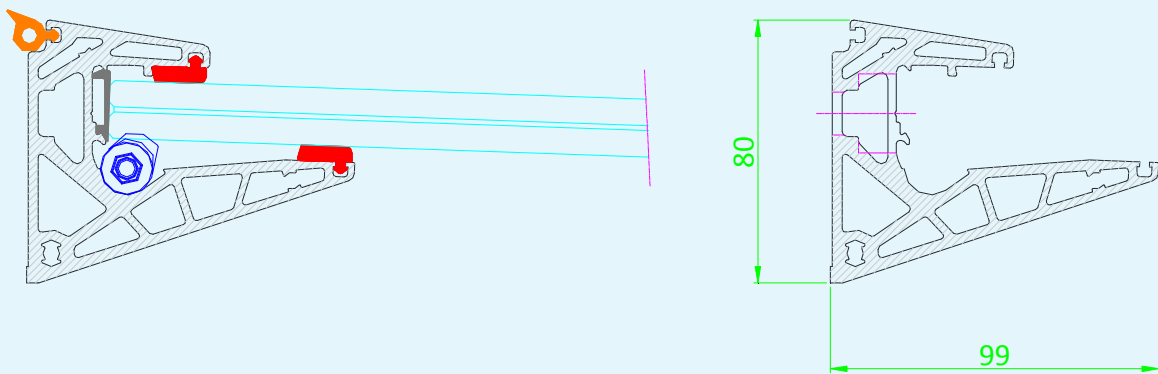
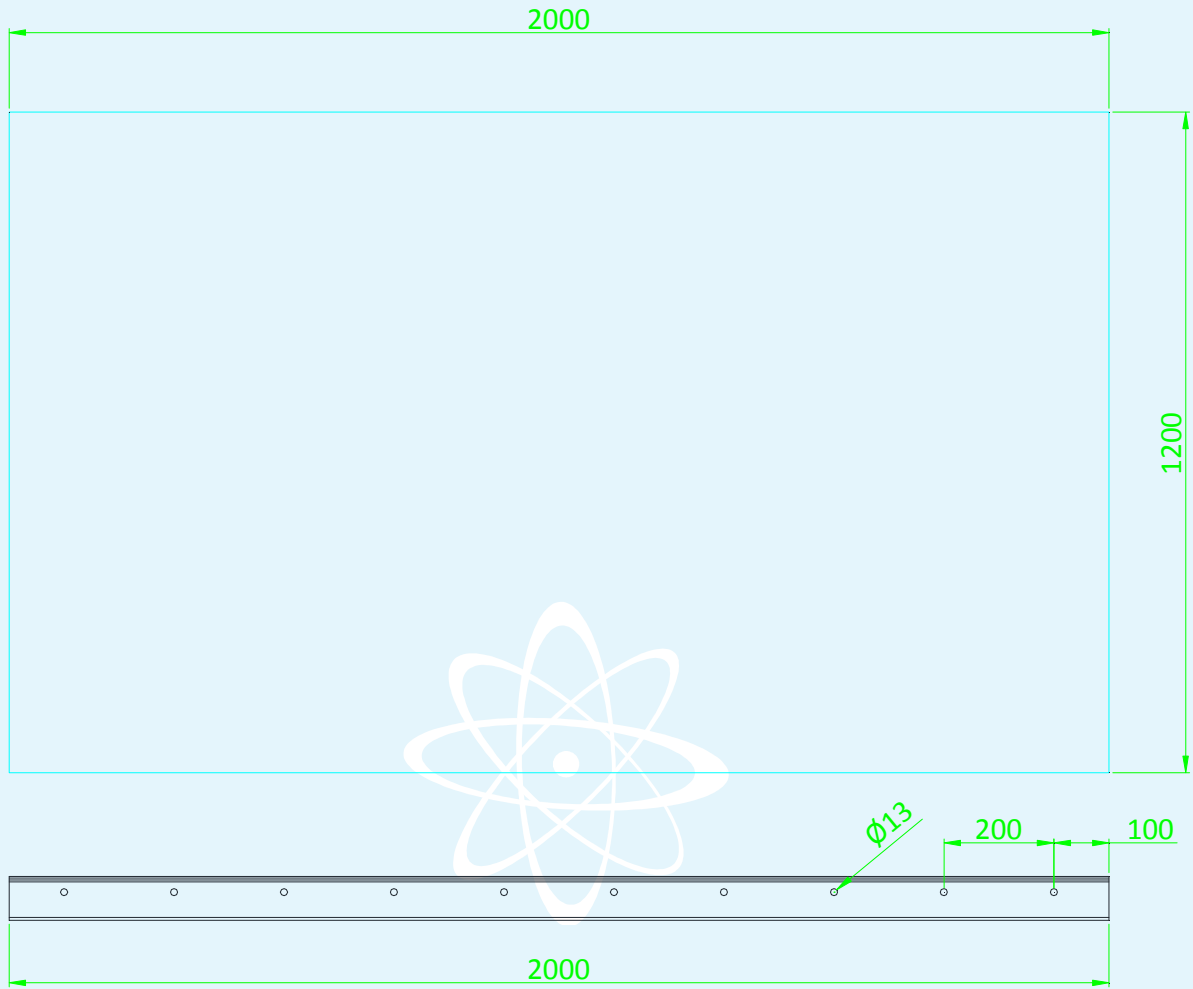

Specimen

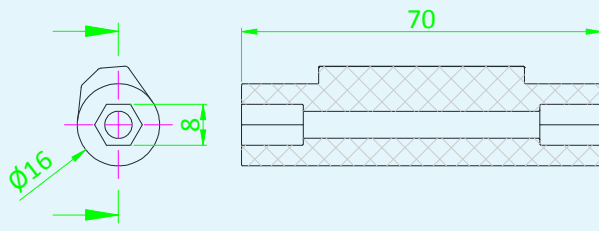

Cam

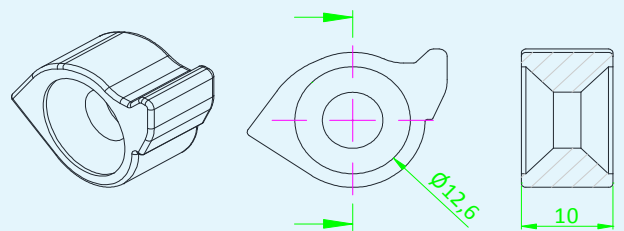

Safety catch

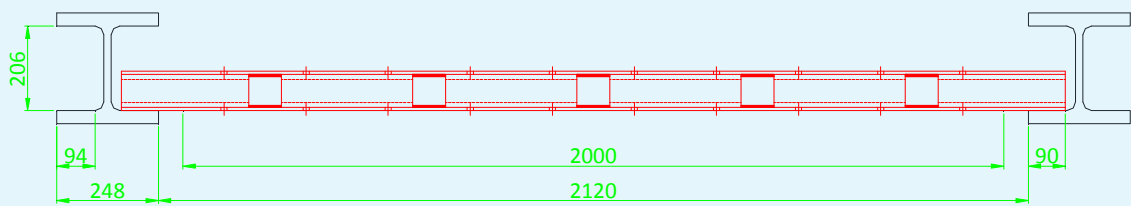
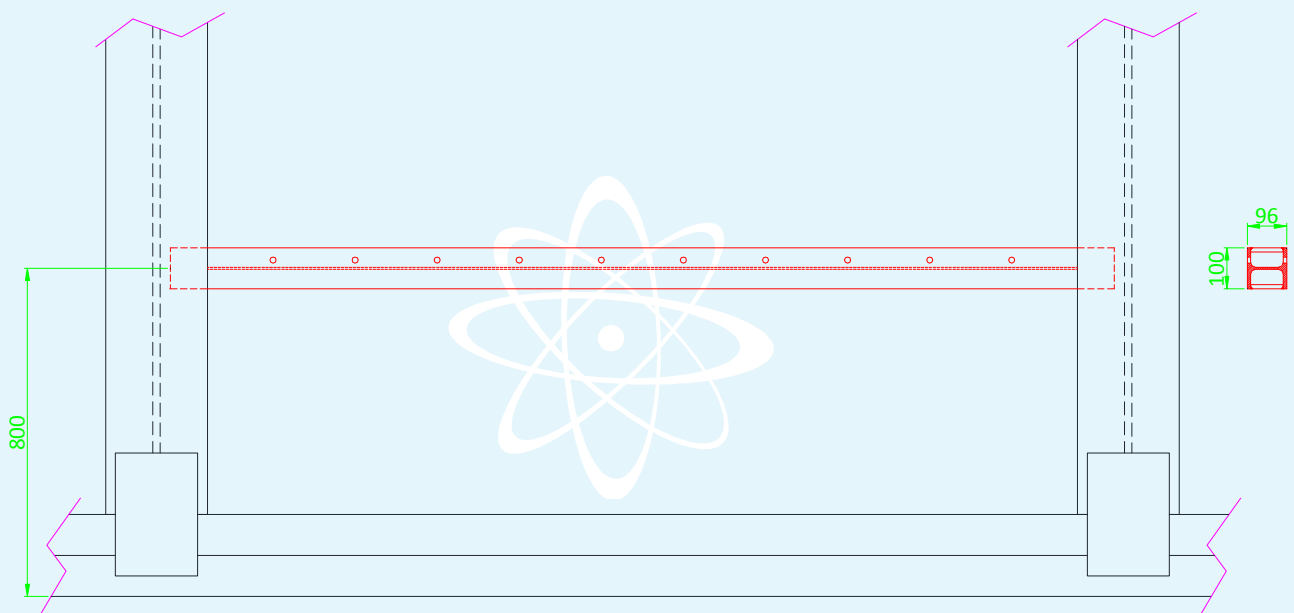

Test frame

Test apparatus

The following equipment was used to carry out the test:

- steel test rig;
- loading mass comprising:
 - bags of lead, weight 5 kg each;
 - steel discs, weight 10 kg each;
- 2 displacement gauges with 0,01 mm resolution, one analogue type and one potentiometer.

Test method

The test was carried out in accordance with Customer instructions, securing the specimen to the test rig using its test frame and applying a uniform load to the glazing panel using the loading mass.

After positioning the loading mass, deflection was measured at each load step using the two displacement gauges with 0,01 mm resolution arranged as shown in the photo on the next page.

Environmental conditions during test

Average ambient temperature	30 °C
Average relative humidity	46 %

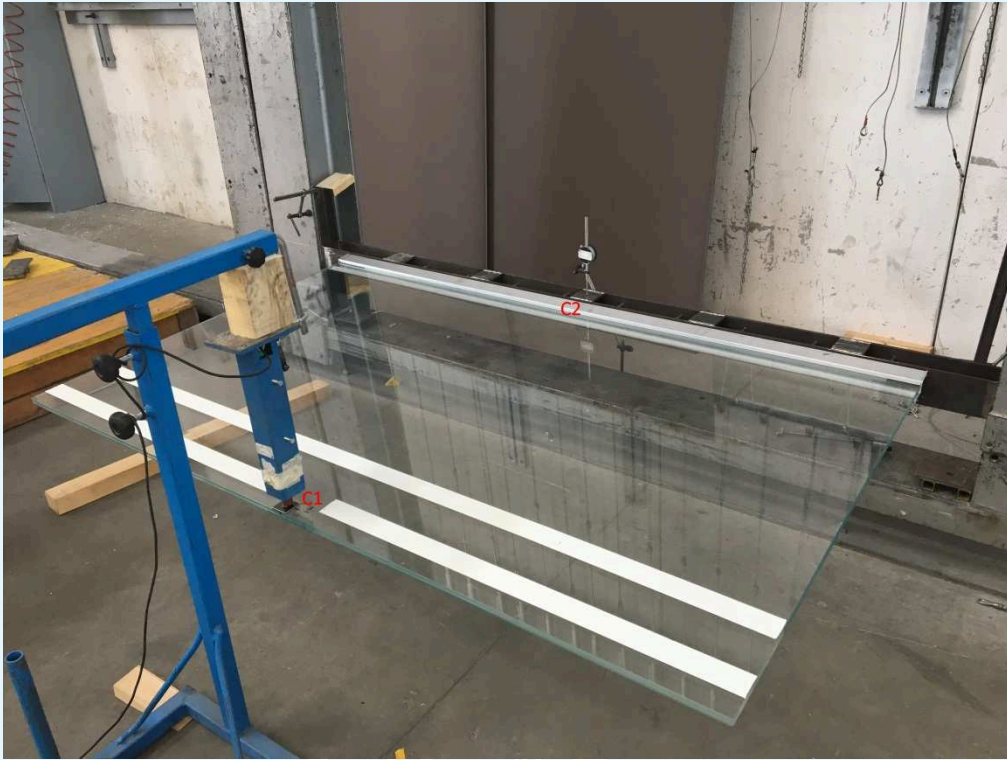

Specimen photo showing measuring points

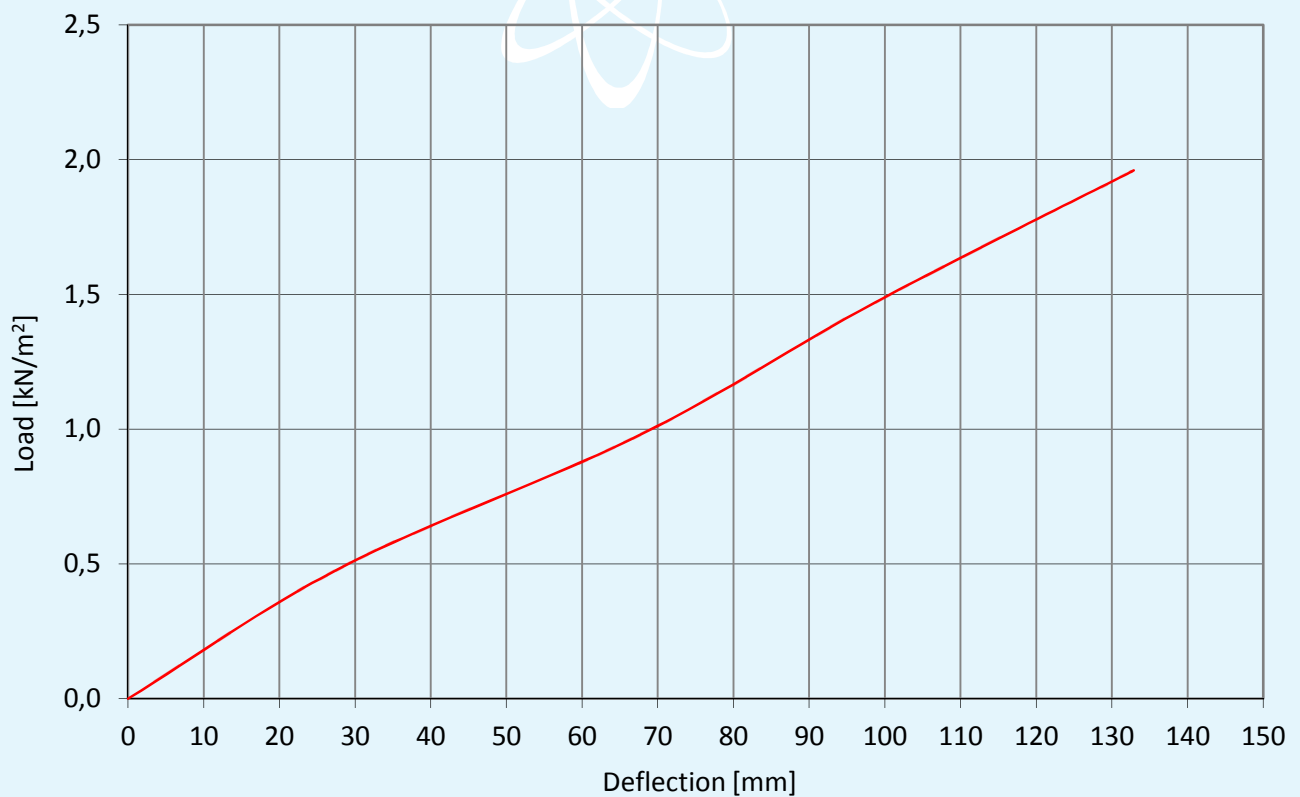

Photo of specimen during test

Test results

Load applied				Deflection under uniform load		Notes
[kg]	[kN]	[kg/m ²]	[kN/m ²]	at point "C1" [mm]	at point "C2" [mm]	
0	0,00	0	0,00	0,00	0,00	//
120	1,18	50	0,49	28,40	0,04	//
240	2,35	100	0,98	67,75	0,67	//
360	3,53	150	1,47	98,70	-0,82	//
480	4,71	200	1,96	132,90	-1,52	//
840	8,24	350	3,43	//*	//*	no breakage

(*) the displacement gauges were removed following completion of the previous load level.



Load/deflection curve for point "C1"

Findings

On the basis of the test performed, the test specimen, comprising a shelter called "LA PENSILINA-SG" submitted by the company LOGLI MASSIMO S.p.A. unipersonale - Via Chemnitz, 49/51 - Zona Industriale Macrolotto 2 - 59100 PRATO (PO) - Italy, obtains the results given in the following table.

Length "Z" [mm]	Projection "L" [mm]	Maximum load achieved without failure	
		[kg/m ²]	[kN/m ²]
2000	1200	350	3,43



Test Technician:
Ing. Matteo Naviglio

Head of Security and Safety Laboratory:
Dott. Andrea Bruschi

Chief Executive Officer

.....